

A stylized, light-colored outline of a human figure is positioned on the left side of the cover. The figure is composed of simple geometric shapes and lines, representing the torso, arms, and legs. It is set against a background of a bright yellow sun with rays emanating from it, creating a high-contrast, energetic feel.

Power Tool Ergonomics

EVALUATION OF POWER TOOLS

Revised digital edition 2022

Atlas Copco

Power Tool Ergonomics

EVALUATION OF POWER TOOLS

Revised digital edition 2022

Acknowledgements

While doing research for this book, I found that there were gaps in the scientific data available. My colleagues' comments, based on years of practical experience, have been very valuable in helping to fill these gaps. Among the persons consulted with scientific backgrounds I would like to mention Shihan Bao. Shihan completed his Ph.D. thesis, "Shoulder-neck exposure from assembly work, and the significance of rationalization", around the time I began writing this book. He participated in the research related to his specific field and made a very valuable contribution. Warm thanks to Shihan and my colleagues for their encouragement and support.

Bo Lindqvist

*Authors: Bo Lindqvist, Lars Skogsberg,
Frida Graf, Romain Haettel, Ava Mazaheri
Editorial consultant: David Bennett, Rafaella Turander
Cover design: Mikael Skoog
Illustrations: Martin Gradén
Photo contributions: Jonas Brane, BLR-fotograferna,
Dennis Josefsson, Rolf Kukacka, Lars Lindgren,
Björn Lundbladh, Lars Nybom, Jan Strömberg,
Dag Sundberg, Kenneth Westerlund*

*A know-how publication from Atlas Copco
ISBN: 978-91-527-0284-0*

*Atlas Copco Printed Matter
No. 9833 1162 01*

Preface to revised digital edition

This revised version of Power Tool Ergonomics is only available in digital format and mainly includes updates of standards and references. Adjustments were made in the section on Temperature where research has resulted in new standards with new limit values for exposure to cold surfaces. This also implied a modification of the temperature scores included in Evaluation of Power Tools (Chapter 4). Furthermore, the sections on External Load, Shock Reaction, Vibration, Noise, Dust and Oil were corrected and updated with current standards.

*Frida Graf
Sr. Ergonomics Specialist
2022*

Preface to the second edition

The first edition of this book was the last major contribution that my late colleague and good friend Mr. Bo Lindqvist made to the science of power tool ergonomics. It was with great reluctance that I undertook the task of upgrading this book to a second edition. The unique evaluation method that he presented in the first edition has been very well accepted and his method is used by many large companies in Europe and the US. I feared that I would, to some extent, take the credit for this major contribution away from him. However, as time passes, things change, I now believe that the best way to show my respect for Bo is to carry on his work and further develop his method based on new knowledge, new standardization and the experience gained from the use of his method.

In this second edition I have only made the revisions necessary to bring the book up to date. Some of the graphs for conversion from evaluated parameters to points are adjusted. I have added a section on wrist torque based on recent research conducted by Atlas Copco. The sections on noise and vibration have been revised slightly to reflect the new situation in Europe following the publication of the Physical Agents Directives for noise and vibration. The examples at the end of the book have been updated and are based on the most modern tools on the market. In addition, some photos have been replaced by images that reflect the current situation more accurately.

*Lars Skogsberg
Manager, Product Ergonomics*

1. The workplace

Good ergonomics is good economics	8
Work organization	12
Sitting assembly workstation	15
Standing workstation	21
Standing assembly line workstation	27

2. Main types of power tools

Grinders	32
Drills	37
Percussive tools	41
Screwdrivers	45
Impact and impulse nutrunners	49
Angle nutrunners	53
High torque nutrunners designed for use with reaction bars	58

3. Evaluation of power tools

Introduction	62
Handle design	64
External load	73
Weight	88
Temperature	92
Shock reaction	97
Vibration	103
Noise	116
Dust and oil	125

4. Evaluation examples

Grinder GTG 40 F085	134
Drill LBB 26 EPX-060	138
Chipping hammer RRF 31	142
Riveting hammer RRH 06	146
Screwdriver LUM 22 PR4	150
Impulse nutrunner, ErgoPulse EP9 PTX80-HR13	154
Electric nutrunner ETP ST32-05-10	158
Angle nutrunner LTV 29 R30-10	162
Electric angle nutrunner, Tensor ST61-50-10	166
High torque nutrunner LTP51	170

How to get the best out of this book

If, like most of us, you're in a hurry, go directly to Chapter 4 where you will find examples and a diagram showing a comparison of ergonomic factors for the type of tool you are interested in. Here you will find an evaluation of the ergonomic factors mentioned in the book.

Each diagram gives an evaluation of one particular tool and an idea of what to expect from other tools in the same family.

Don't be discouraged by the amount of information the book contains – it is not intended to be read from cover to cover in one heroic attempt.

Good ergonomics is good economics

The first chapter deals with the planning and operation of a production unit and typical work environments where power tools are used.

Main tool types

The next chapter describes several main types of power tool and includes brief comments on ergonomic factors influencing the operator.

Guide for evaluation

The idea is to develop a method for comparing the impact of some major ergonomic factors on the operator during the work process. The method provides a systematic approach to assessing the ergonomic aspects of a tool in order to identify problems and areas requiring improvement.

The state of the art

The final chapter gives examples of specific tools. We believe them to be the best on the market. As such, they represent the state of the art for hand-held tool design. These tools are evaluated using the guide.

Preface

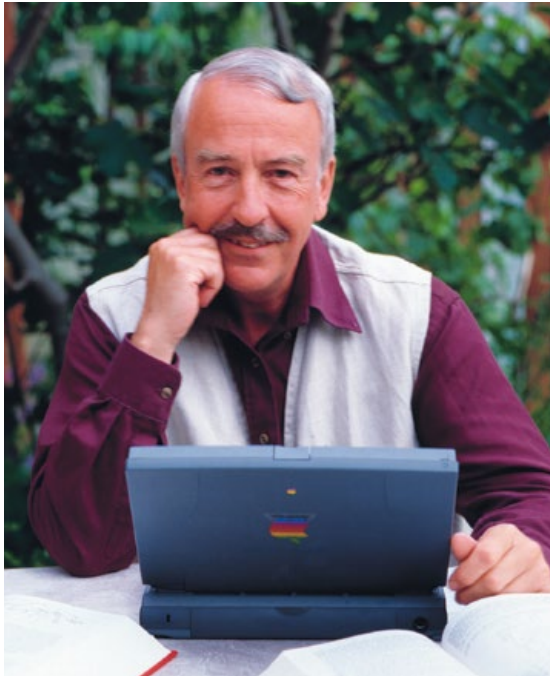

The author, Bo Lindqvist.

Ergonomics at Atlas Copco Tools

As a company developing hand-held power tools, Atlas Copco Tools has for decades been aware of the importance of ergonomics in design.

Atlas Copco first began applying ergonomics in the 1950's during the development of a drill. Medical experts were consulted frequently at the design stage and asked to give

their opinions on different grips. The result was a machine that quickly became popular on the market.

In the late sixties Bo Lindqvist was employed to start a tool ergonomics department.

An acoustics laboratory was built at the beginning of the seventies, and research into noise and vibration began. In the middle of the same decade Atlas Copco introduced a vibration controlled chipping hammer. This tool was the first of a long series of noise and vibration controlled tools and we are still improving our skills to design even better tools.

During the early seventies we also designed and installed a spot suction system in a vehicle repair shop. This project showed that it was technically possible to equip a hand-held tool with a dust collector and suck away the dust created by the process, without obstructing the operator too much in the performance of his task.

Other ergonomic factors have been studied, such as shock reaction from angle nut-runners, and machines have been designed with very fast clutches to minimize the impulse that strives to move the machine in the operator's hands.

Work with international standards

In the late seventies Bo Lindqvist became the chairman of Pneurop 17 Vibration and, subsequently, convenor for ISO/TC 118/SC 3/WG 3, an international standards group charged with the task of developing standards for vibration measurement. The group's efforts resulted in a series of standards designated ISO 8662, now replaced by ISO 28927.

Previous edition

The first edition of Power Tool Ergonomics was published in 1997 and distributed in 40,000 copies.

New possibilities

Over the years we have experienced remarkable developments in measuring instruments and computers. Today it is easier to analyse a phenomenon. We can use multi-channel vibration measurements to see a motion, or we can produce the same effect in a simulation at a very early stage of the design.

The purpose of this book

Historically we talked about ergonomic tools. Nowadays, we talk about tools with good ergonomics. The reason is that in every design we try to find the best possible solution, weighing up a combination of ergonomic, technical and economic factors against each other. This is a complicated task and this book deals only with ergonomic factors, although for the operator other factors may be equally important.

In order to give the subject of power tool ergonomics a framework into which we can place our views and experience, we have selected a number of factors and developed an evaluation method to compare them.

Our task is not made any easier by the lack of research data for some ergonomic factors, although this is a familiar situation for us in the manufacturing industry. We cannot afford to wait for solid data. We often have to make an educated guess and trust our experience. Otherwise we would soon be out of the market.

When you select a hand-held power tool, you not only influence the process, but also the operator's work situation and the entire working environment. The aim of this book is to illustrate this interaction.

1

THE WORKPLACE



Good ergonomics is good economics

When planning a production unit, it pays dividends in the long term to consult people qualified in ergonomics. They help to ensure that both the workplace and the task are compatible with the majority of operators who will work there. Thus, future costs arising from work-related health disorders among operators will be reduced, along with costs arising from poor product quality. Moreover, the need to redesign the production system later may be avoided.



When planning a production unit, involving ergonomists from the start avoids problems later.

Costs related to bad ergonomics

The driving force for all ergonomists is to reduce the number of people suffering from work-related disorders. However, the accessibility of funding for the required improvements in the workplace depends heavily on economic factors such as payback time and return on investments.

Today, the direct and indirect costs of work-related disorders are an increasingly frequent topic for discussion.

Obtaining figures for these costs from companies is difficult. This is partly because many companies have not made such calculations, and partly because those who have are reluctant to release the information to the public.

Some general figures can be given. Large companies spend 10-100 million USD on work-related disorders every year. The cost of taking care of one case of carpal tunnel syndrome is 10–30 000 USD.

This is only the direct cost. The indirect costs generated by work-related disorders are primarily in connection with productivity losses and quality problems. The relationship between direct and indirect costs is not really known, but indications are that the indirect cost may be in the order of three times the direct cost.

Today we see a growing demand for more scientific research in this field. When the true extent of costs related to bad ergonomics is made public, the possibilities of obtaining funding for workplace improvements will be much improved.

Ergonomics

Ergonomics combines knowledge from three disciplines – human science, work-related sciences and production science. Few ergonomists cover the entire field and it is usually personal interest that determines the individual's profile of expertise.

Teamwork contributes to the total knowledge available. In a planning situation all team members can become ergonomists in their search for human and practical solutions. The role of the trained ergonomist is to support the team and try to identify in advance work situations where excessive loads are likely to be placed on the operator.

Operator involvement

An operator with a high level of job satisfaction can be motivated to work more efficiently and to become more actively involved in the production system. Thus, increased productivity and improved product quality can be expected. Compatibility between machine, work organization and operator is therefore crucial to work performance and product quality.

If the physical and psychological demands of a production system exceed an operator's capacity for a prolonged period, the operator may suffer work injuries. Improving the interaction between the operators and their working environment is a major task on the agenda of most industries.

To achieve the ultimate goal of increasing overall productivity, an optimal interaction between the operators and their working environment should be established, and poor interaction eliminated.

This task calls for simultaneous study of the work organization, machines, workstations, production procedures, the physical and psychological capabilities of the employees, and the combined interaction of all these elements.

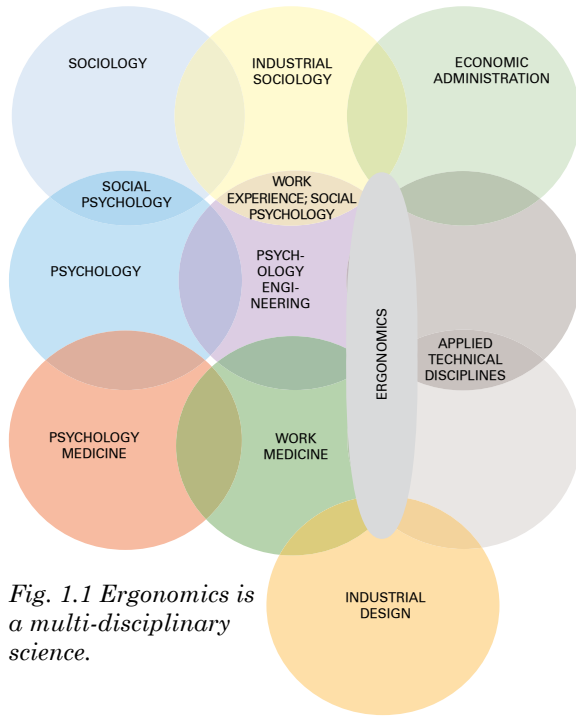

Fig. 1.1 Ergonomics is a multi-disciplinary science.

Adapting the workstation to the operator

Every workstation is unique. The human being represents the largest collection of variables, therefore a workstation that suits one operator perfectly may be a disaster for another. This could be one of the reasons why problems often arise unexpectedly when a new production unit is started up.

In the past, attempts have been made to set up a performance profile for every operator and compare this with a specified demand profile for each workstation. These attempts

were not successful, however, because the degree of sophistication of the human body defies efforts to encapsulate its parameters neatly in a performance profile. The workstation itself is also quite complicated.

It is important to design workstations where every member of the actual workforce can work comfortably. This calls for a large degree of adjustability that often increases the cost. However, the investment can be justified by the resulting high flexibility.

In recent years a clear trend has emerged where ergonomists in large companies are increasingly involved in the development of the next generation of products. Decision-makers are realizing that the most cost effective way to improve ergonomics in production is to design a product for easy production. The need for workstations that are badly designed from an ergonomics viewpoint is thus eliminated.

Power tool ergonomics

Operator comfort also depends on the power tool selected. In our range of pneumatic and electric nutrunners there are several different versions capable of tightening the same joint. They are designed for different purposes.

For example, an impact wrench might be chosen for a vehicle repair shop, or a computer controlled electric nutrunner for safety joints in the automotive industry. All the tools are differ-

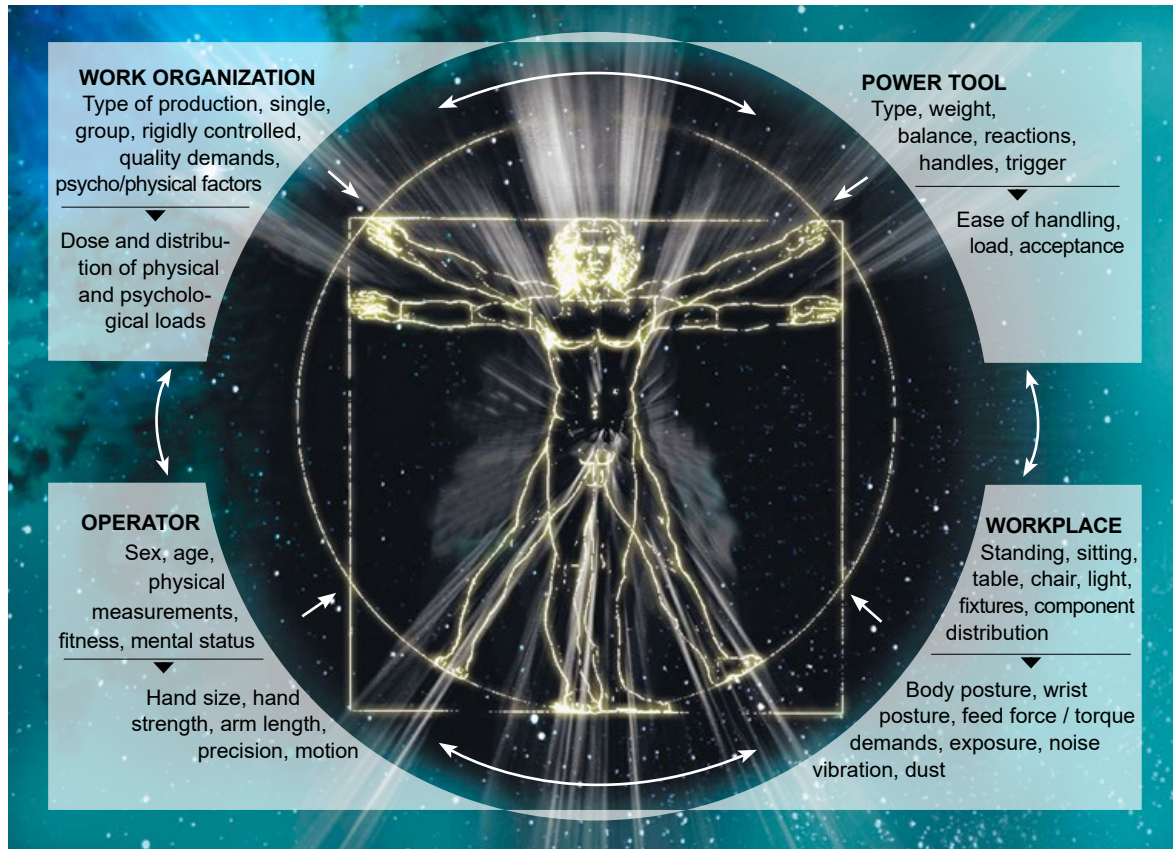

Fig. 1.2 The workplace is a complex structure. All aspects however small affect the finished result.

ent in terms of shape, center of gravity, weight, noise, lubrication requirements, vibration and other factors. Yet each tool is capable of installing a joint with the same torque.

The selection of tool influences the user of the tool. In reality, you are unlikely to find yourself in a situation where you need to choose between all the different tool types. Therefore

the question may seem academic. Nevertheless, it is an aspect worth bearing in mind.

The selection of a power tool is an important parameter for workstation design. Ironically, the best power tool on the market will not transform a badly designed workstation into a safe, comfortable work area for the operator.

Work organization

No organization is static. If operators at all levels are encouraged to improve their knowledge, the efficiency of the organization will gradually improve. An ongoing process where investments in

machines and the workplace go hand-in-hand with operator training will be perceived as the natural state of things by the employees and form the foundation for a high level of job satisfaction.



Assembly work should be as varied as possible to avoid repetitive motions.

Trends in modern work organization

To be competitive in today's market, a company should be able to respond smoothly to its customers' demands for different models and mixes of products. This calls for a new approach to work organization and a number of new systems are being used by modern industry.

These systems have certain common characteristics. For example, many production systems have now changed from the old type of "push" system to a "pull" system (order-based management).

New types of production systems are usually more integrated than their predecessors. This has been achieved by uniting the different departments; for example, design, marketing and production, to improve communication within the production system.

Another characteristic of today's production systems is flexibility. Operators are usually multi-skilled and thus able to perform a number of different tasks within the group. The barriers between operators, maintenance staff, white-collar workers, engineers and marketing personnel are being broken down. Operators are expected to forge contacts with other personnel, both within and



Modern production methods place greater demands on the individual operator.

outside the production system, and efficient networking is a growing trend.

Many new systems have a learning organization in which employees are encouraged to participate by expanding their personal skills. Active psychological involvement of the workers in the production system allows them to make major contributions to the improvement of productivity, product quality and working conditions.

Working conditions – an important factor

Working conditions are another important issue in the improvement of work organization.

Nowadays, ergonomic principles are used in work organization studies. In many modern industries, correct distribution of tasks between human beings and machines has eliminated the need for heavy physical work on the part of operators. In the new production systems, varying an operator's tasks helps to eliminate disorders caused by highly repetitive, monotonous work tasks. The level of job satisfaction seems to be much higher in many of the new production systems.

The 21st Century started with the big Asian markets rapidly entering the competition. There is growing demand for decreased



Learning is a continuous process and an interchange of ideas and knowledge.

production costs in Europe and the USA. This can be seen, for example, in the trend to return to line production where group assembly was earlier tried. This poses a real challenge for the ergonomists. We want to keep the benefits that have been gained over the years in this new production environment.

Sitting assembly workstation



The majority of workplaces have sitting workstations. Sitting is a good posture, particularly for high precision jobs. However, the sitting posture limits the operator's reach and sometimes the task requires the operator to pick up components at the edge of his reach distance. If this movement becomes highly repetitive, there is always a risk of shoulder and neck problems. Sitting workstations should be designed so that the operator has to stand up and walk around from time to time. The human body was not designed to maintain the same posture for long periods of time.

The operator should not be restricted to just one working position, such as sitting, for example.

A seated operator usually has good stability and is thus capable of performing tasks requiring precision or fine manipulative movement, especially if provided with armrests.



Static load on the neck and shoulder muscles should be reduced where possible. The static load increases with the angle of the head in relation to the vertical plane.

However, when seated, the operator has less mobility and is unable to apply the same degree of force.

When applying ergonomics to the design of a sitting workstation, working postures and musculoskeletal load must be taken into account. This is particularly true for the low back, the shoulder, and the upper extremities. Ergonomic workstation design means careful study of the relationships between workstation, seat, tools and tasks to be performed (i.e., product design and method of manufacture), with the aim of improving working postures and reducing musculoskeletal load. The operator's reach range and force capacity in a sitting position are also important design criteria.

The work table and chair

According to general ergonomic guidelines, working for long periods with the shoulders elevated or the arms fully extended should be avoided wherever possible. Work should be performed with the trunk upright and the head in an upright or slightly forward position, to avoid undesirable twisting. It is also important to provide sufficient legroom.

Due to the anthropometric differences between individual operators, i.e., the

variations in physical measurements, few workstations will accommodate all workers ergonomically.

For this reason, an important ergonomic feature of a sitting workstation is the adjustability of the chair and/or table. The workstation should be designed so that an operator can adjust it quickly and easily to his or her own physical measurements. Operators should be encouraged to adjust their workstations to the tasks undertaken.

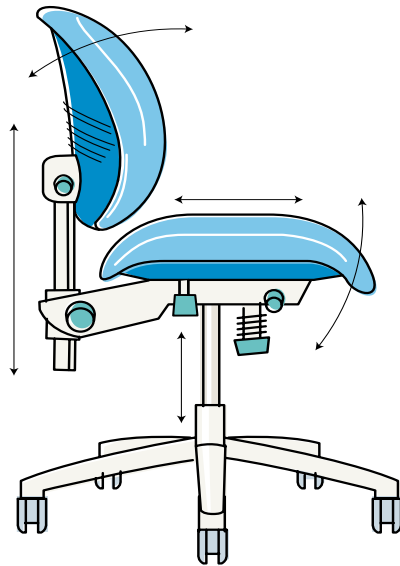

Fig. 1.3 Flexibility is a key factor.

Reach ranges and force capacity

To determine where parts or hand tools should be located or placed, it is necessary to consider the reach range. Naturally, reach ranges are limited by the physical measurements of the individual worker. Here, there are two individual concepts that a designer should be familiar with: (1) zones of convenient reach; and (2) the normal working area.

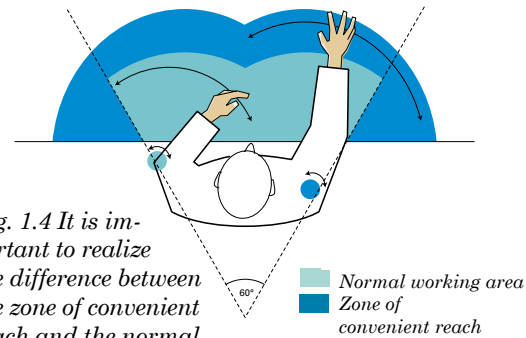

Fig. 1.4 It is important to realize the difference between the zone of convenient reach and the normal working area.

A zone of convenient reach is a zone in which an object may be reached conveniently without undue exertion. The zone of convenient reach is determined by the length of the operator's arm. The dimensions of a workstation layout are usually such that 95% of all workers at the workplace are able to reach the necessary points in the area

without stretching the trunk. The intersection of a horizontal plane, such as a work table, with the zone of convenient reach defines what industrial engineers usually call the maximum working area. Within this area, there is a much smaller “normal working area”, described by a comfortable sweeping movement of the upper limbs about the shoulder with the elbow flexed to 90 degrees or slightly less.

When the elbow is flexed to 90 degrees and the upper arm is rotated at the shoulder about its own axis, the comfortable limit of outward rotation is only about 30 degrees.

This factor, together with the average arm lengths of the workers at the workplace, can be used to determine the “normal working area”.

Work postures

As the arm moves between different locations in the working area, the lengths of the arm muscles change. The length of a muscle is an important factor in its capability to generate tension. Extreme arm postures should be avoided. This factor should be considered in the design of workstations and selection of hand tools, particularly for operations requiring a degree of force.

Muscle groups

Different muscles have different capacities to generate tension. Correct task design will allow operators to generate higher force. For example, if self-tapping screws are to be tightened, a high feed force is required, therefore a pistol grip tool should be used. A pistol grip is superior to a straight grip in terms of transferring feed forces, because the muscle groups used to flex the upper arm have a higher force generating capacity than those used to extend it.

Workpiece and tool selection

The working posture is, to a large extent, determined by the workpiece. To improve poor working postures (where suitable tools are already being used), the positioning of the workpiece and/or the method of manufacture should be examined. A rotatable fixture may be needed at some assembly stations where tasks are carried out in different directions.

When there is a considerable distance between the top height and bottom height of the tasks performed, an adjustable working height may be considered.

A tiltable work surface allows a better head posture.

Load-reducing measures

In many industrial situations, reducing load is not an easy task due to the constraints of tool/product weights, or because the nature of the tasks or the work organization result in repetitive or extended load situations. In such cases, alternative load-reducing measures may be considered. Commonly used load reducing devices include arm-rests, arm slings, and weight balancers.

Arm-rests may be used for assembly or repair tasks where the arm has to be held away from the body and is not moved extensively during the work cycle. The height should be properly adjusted to suit the

individual operator and to provide the best support for the arms and for the tasks undertaken. Arm-rests should be well padded, they should permit easy movement of the forearm and have no hard edges that could cause discomfort. The arm-rests should be located near the front surface of the workstation, but should be easily adjusted to suitable positions for the variety of tasks an operator may have to do. They should tilt without requiring manual re-adjustment. Armrests on a chair are best positioned slightly below elbow height when sitting, if a relaxed posture is to be achieved. Wrist supports can also be useful for complex assembly work, to stabilize the hands.



The selection of handle type can have an adverse effect on posture.



Weight balancers reduce fatigue

The weight of a hand tool, particularly a power tool, imposes limitations on the length of time that an operator can perform the task, while reducing the degree of precision that the operator can achieve. In general, any tool weighing more than 2.5 kg that has to be operated while supported by the arms, or tools that has to be held out from the body in an awkward posture should be provided with a “weight balancer”.

Torque arms

Reaction forces and the weight of the tool can be relieved from the operator by using a torque arm. In addition, it is possible to apply a tool positioning system to the torque arm, that can be used to automatically change the tool settings for specific joints and/or verify that each bolt is tightened correctly.



Standing workstation

A standing workstation allows an operator to apply higher forces and provides him with greater mobility than a sitting workstation. A number of ergonomic considerations can help the operator use the standing working position to its greatest advantage and minimize the potential risks of standing workstations.



To allow good postures for different operators, the height of the workstation should be adjustable.

A standing workstation may be the best alternative in the following circumstances: (1) considerable muscle force is needed; (2) frequent high, low or extended reaches are required; (3) downward force must be exerted; (4) knee clearance is limited for a seated operator; (5) the workpiece is too high to take both the upper arm posture and the knee space into consideration. The overall aim of the ergonomic design principles for a standing workstation is the same as for the sitting workstation, i.e., to avoid unnatural postures.

Extreme working postures

In some standing work situations, it is not possible to achieve acceptable working postures. For example, many construction operations involve working above shoulder level. In such situations, it is important to reduce the load on the static muscles and to shorten the duration of each operation. The static muscle load can be lowered by reducing the weight of the tools and by



Extreme working postures in real life.

holding the tool close to the body (reducing the amount of arm leverage applied). The duration of individual operations can be shortened by shifting frequently between tasks which use different muscle groups. Here, ergonomic administrative controls are needed to reduce the risk of static muscle load over long periods.

Providing the operator with the correct working technique is also an important basic factor in reducing the risk of musculo-skeletal injuries. When lifting from the floor, the operator should be encouraged to bend his or her knees instead of the low back.

Applying force when standing

In standing position, high forces can usually be generated with the help of the body weight. Therefore it is important that the standing workstation is designed to allow the operator to use his body weight when a high degree of force needs to be applied. For example, in performing sanding and polishing tasks, the work surface should be in the horizontal plane, slightly below elbow level. This is particularly important during lengthy operations such as sanding and polishing. Otherwise, the relatively weak arm muscles will be over-exerted and the work performance impaired.

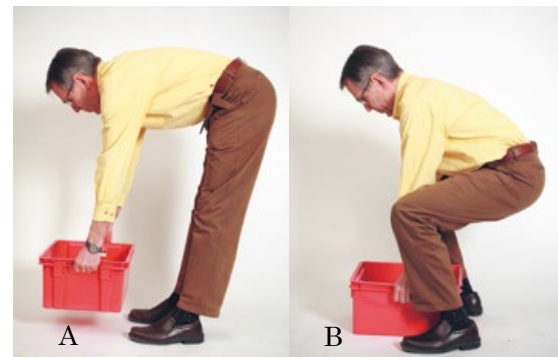

Fig. 1.5 Using the right working technique. This figure shows two situations: (A) lifting an object from the floor by bending the back – the wrong technique; (B) lifting an object from the floor by bending the knees – the right technique, if your knees can take it!

Adjustable platforms are useful in this respect, since they can be set to the working height which allows the operator to apply maximum force. The adjusting mechanism should allow the operator to make the adjustment quickly and easily. Otherwise, the operator may be reluctant to make the necessary adjustments. In some situations, horizontal work surfaces may not be feasible. A working height slightly above elbow level is usually needed to obtain an acceptable working posture for horizontal force applica-

tions. When high feed forces are demanded, such as in some drilling, chipping and scaling tasks, the operator should take advantage of his body weight by leaning slightly forward. Sufficient standing space should be provided in order to achieve a stable standing posture when applying force. Where a high degree of horizontal force is to be applied ($> 200 \text{ N}$), friction between the shoes and the floor should also be taken into consideration, to avoid slipping. In the ergonomically planned workplace, care is taken to reduce the risk of



On modern production lines cars can often be adjusted in height to allow good postures for the assembly operators. This is especially important where high feed forces are applied.



Working with high feed forces requires the operator to lean forward slightly in order to make use of his body weight.

an operator slipping or tripping over. An operator's footwear should be selected according to the degree of horizontal force to be applied and the floor surface. Special attention should be paid to the slipperiness of the floor surface when dry, and when wet from spilled materials or cleaning operations. Non-slip coatings, such as paint containing sand, have successfully reduced the risk of "slip-and-trip" accidents in areas where wet floors are common. However, increased friction may make walking or manually maneuvering a vehicle difficult.

Operator comfort in the standing workstation

Shoes with well-cushioned insteps and soles, and/or rugs or mats can be used in standing workplaces to improve operator comfort. It has been shown that working in a standing position for prolonged periods causes discomfort due to (1) prolonged static muscular effort in the feet, knees and hips; and (2) increased hydrostatic pressure of the blood in the veins of the legs, and general restriction of lymphal circulation in the lower extremities.

It is, therefore, important that the standing operator is provided with the facilities to sit down frequently and rest his or her leg



On modern assembly lines considerable effort is invested in finding safe solutions for work tasks that would otherwise place heavy loads on the assembly operator, while requiring him or her to adopt awkward postures.

muscles. From a physiological and orthopedic point of view, a workstation which allows the operator to sit or stand, as he wishes, is highly recommended. Since standing and sitting impose load on different muscles, variations between the two positions will reduce the risk of statically loading single muscle groups.

Varying the working position between standing and sitting can also stimulate the supply of nutrients to the intervertebral discs, which is also beneficial to the operator's

health. It is also crucial to design the workstation so that the operator can walk around it rather than stand in one place. During walking, the muscles of the legs act as a pump, which compensates for the hydrostatic pressure of the veins by actively propelling blood back towards the heart. It is also helpful to provide a foot rail (foot-rest) so that the operator can rest his feet, one at a time. This varies the hydrostatic pressure of the veins and improves blood circulation in the legs.

Working areas of a standing workstation

The forward reach area is determined by the zones of convenient reach or the “normal working area” as discussed in the section on the sitting workstation.

Occasionally, tasks may lie outside the zones of convenient reach. An operator may have to extend his reach by leaning, stretching or stooping. Any one of these postures can easily produce fatigue if assumed frequently or maintained for periods longer than one minute.



We're all different!

If the arm and forearm are elevated to a nearly horizontal position when reaching forward, a load of only 56 N in the hands will create a load moment at the shoulder equivalent to the maximum flexor strength moment predicted for the average female. A 115 N load will be equal to the shoulder lifting strength of the average male. Therefore, if such situations occur, the task should be of an occasional nature, such as activating a switch. The physical strain imposed on the operator by such extended reaches can be reduced by ergonomic workstation design.

Designing a standing workstation becomes an even more challenging task, when taking into account the wide spread in body measures. Workstations that are used by many different operators must be made adjustable and the operators must be instructed to adjust the workstation to fit their size.

Standing assembly line workstation

Working in a standing position along an assembly line involves a great deal of walking. Although this in itself is good, there is a tendency for operators to try to work themselves upstream in order to allow time to correct any errors without interfering with the work of operators further down the line. This is a stress situation.

Assembly work organization

An assembly line which is equipped with ergonomically designed hand tools, and where interactions between tools, workstations and tasks have been carefully planned, will improve working postures and reduce mechanical load on the operators.

An example of this approach in the automotive industry is the general decision to avoid work above shoulder height. Thus, the car



Sometimes tools are used in ways the designers never even thought of.

body is lifted or tilted, or the power tool is suspended in an articulated arm.

Rig assembly from above

All components to be assembled under the chassis plate, such as the engine drive shaft, exhaust system, wheel suspension, hydraulic pipes and so on, are first assembled in a rig from above.

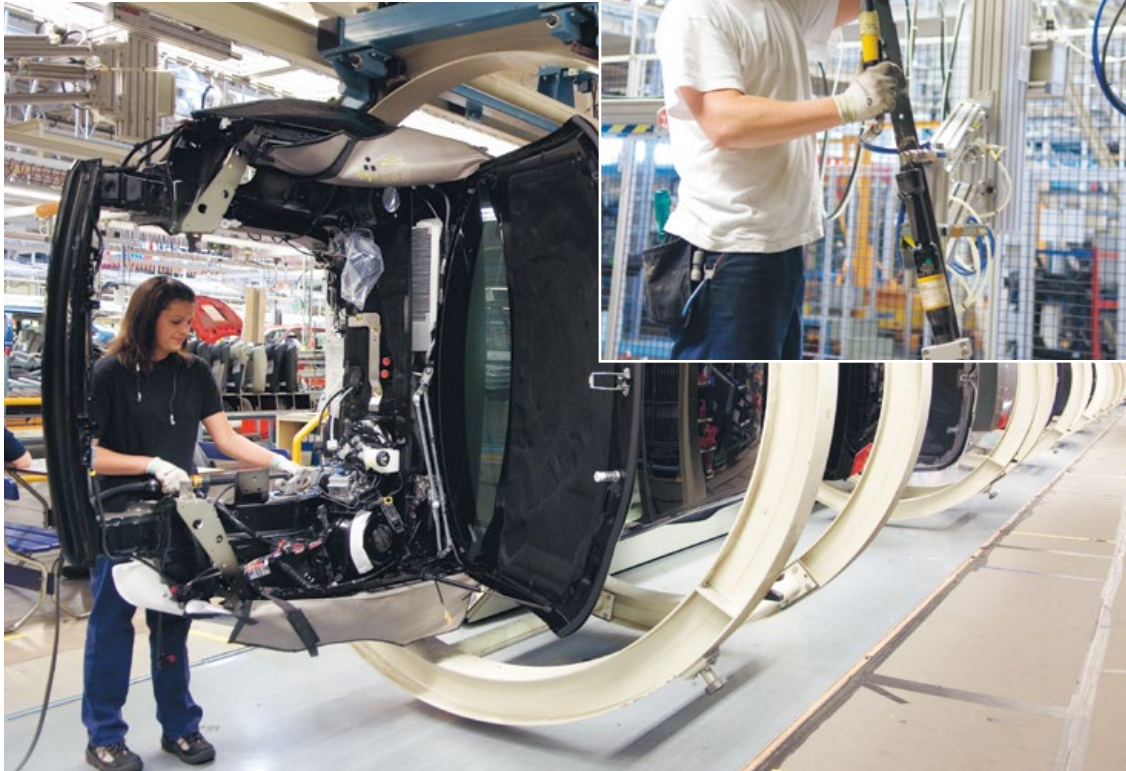

In the automotive industry much effort is put into avoiding tasks that would otherwise require work above shoulder height.

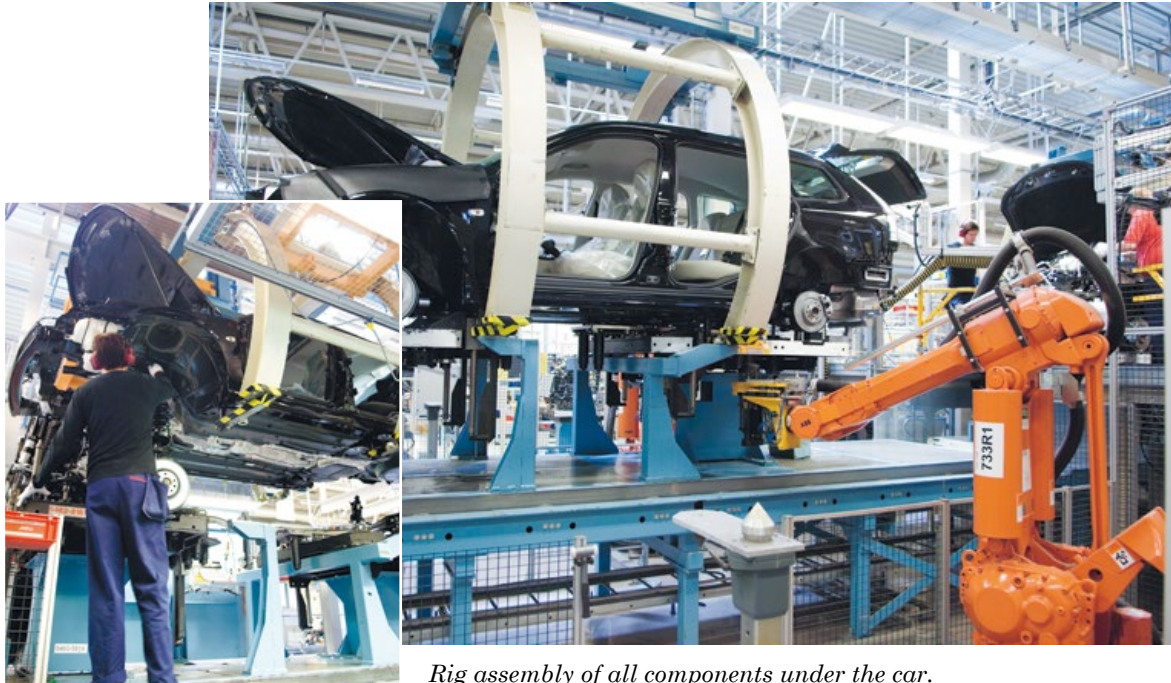

Rig assembly of all components under the car.

Later, the chassis plate is added to the assembly, and the whole package is automatically bolted together with the use of a large number of nutrunners in a rig assembly.

This approach is essential if the risk of work-related musculoskeletal disorders among the operators is to be reduced. However, adopting this approach does not guarantee that the risk is eliminated. Scientific research has proved that workers exposed to even very low external mechanical load (e.g. as low as 1% of their maximum force capacity) may still develop musculoskeletal dis-

orders in situations where the external load is continuous and prolonged. The solution to this problem may be to reduce the monotony of the external load by introducing a more varied load pattern (physical variations).

In the traditional assembly line organization, physical variations may not be introduced easily. This is because the basic principle of the traditional assembly system is to assign simple repetitive tasks to individual assembly workers. Each operator is therefore subjected to repetitive, monotonous external load. It has been proposed that assembly



The team is an important factor in production.

operators in such working conditions should be able to take frequent pauses and switch to other tasks in order to relax their muscles.

Modern methods of organizing assembly work seem to offer greater potential for varying physical exposure on individual operators than the traditional assembly line concept. Nowadays, markets require flexible production systems able to meet changing customer demands. To achieve this, production plans are based on orders already placed by customers. This requires a new type of assembly concept and, in recent years, in some factories the scope of tasks allotted to each operator has been successfully broadened.

In a flexible production system assembly operators have greater responsibility for productivity, product quality and workflow. One trend is that more and more components are assembled elsewhere, and even designed by a subcontractor to the production unit. Less work is done along the line, which makes it easier to design good workstations. The systems usually encourage the assembly staff to become multi-skilled, i.e., increase their skills to include a number of different operations.

Bearing ergonomic principles in mind, this new type of assembly organization enables operators to vary their physical exposure by shifting between tasks in the assembly system.

2 MAIN TYPES OF POWER TOOLS



Grinders

Grinders and sanders are essentially the same machines used with different inserted tools for different purposes. Power outputs can range from 0.1 to 4.5 kW. Weights vary from a few tenths of a kilogram to several kilograms. High power is always a risk factor and operators must be trained to use the tool safely.

Where are they used?

Grinding machines are used where material removal is the primary task – from cutting off pouring ingate, and heavy grinding on large components, to precision die grinding. Grinding machines are suitable for rough or fine sanding of castings. They can be used on huge constructions, such as offshore platforms, or for repairing the bodywork of damaged motor vehicles. Machines of this type will put a fine finish on a plastic boat or give wooden furniture a surface that makes it a pleasure to use.



Before using high powered grinders, operators should be trained to avoid unnecessary risks of exposure to injury, noise and vibration.

Working environment

Grinding and sanding machines are generally found where any form of mechanical work is being undertaken.

Since every work situation is unique, it is impossible to predict with any precision how a machine will be used, or the degree of physical exposure that will be experienced by the operator.

The working environment can be anything from a clean assembly shop, where grinders are used for small finishing tasks, to a noisy, dirty environment where very heavy grinding is taking place.

Design for good ergonomics

Since a natural grip is always the most comfortable grip, handles and triggers should be designed with this in mind. It should also be easy for the user to change his grip on tool – this helps to distribute the load and avoid local muscular fatigue.

Although the operator may not need to apply much muscle power to perform his task, during prolonged working periods the load quickly becomes a static load that can be exhausting. Most grinding tools are held in a two-handed grip that provides stability and distributes the load evenly between both hands.

The lever trigger is a feature of nearly all grinders and sanders. The operator can

either operate the trigger with his fingers or with the palm of his hand.

Safety

Since the power outputs of tools of this type can vary from 0.1 to 4.5 kW, there are always risks involved in using the machines.

The worst accident scenario would be the disintegration of a grinding wheel. Fortunately, such occurrences have been rare. But if it did happen, and there was no guard in place on the machine, a disintegrating wheel could fatally injure a person in the vicinity. So the guard must be in place at all times.

You could always argue that tools of this type should be supplied with permanently fixed guards. But they are normally designed for use with depressed center wheels, cutting off wheels, cup wheels, brushes and fiber discs. In the latter application the machine works as a sander and does not require a guard, but each of the other applications mentioned requires a different guard. For this reason, Atlas Copco supplies grinders with guards assembled, but the guard can be exchanged for a different type when the task changes.

It is extremely important that the operator is fully aware that the speed marked on the machine should never exceed the speed marked on the wheel.

HANDLE DESIGN

The hand grips on grinding machines are normally round or oval in shape. The circumference is generally less than 120 mm, except where the handle is integrated into the machine housing. No machine has handles longer than 130 mm and no handle is shorter than 100 mm. The support handle is rounded at the end, allowing the tool to be held in a number of different ways.

The support handle should preferably be adjustable so that different angles can be set between the support handle and the trigger handle. Thus, the operator can customize the machine to suit himself and the task.

A visco-elastic layer on the handle increases the friction between hand and handle for optimum maneuverability. The layer should be designed to allow good ventilation of the hand. A lever trigger with a safety lock prevents the tool from being activated unintentionally.

EXTERNAL LOAD

When grinding, the operator does not need to apply much force or grip the tool handles excessively tightly. Yet using the right tool for the job and working at a correctly designed workstation are still very important since grinding is usually a long, drawn-

out operation. Operator fatigue is usually caused by the torque generated by the reaction force in the process and absorbed by the operator's wrist.

For rough grinding and cutting, the extra power of the large machines is utilized, giving high process forces. However, the additional weight of these machines places an extra load on the operator.

The tools are designed so that only low trigger forces are required. These are gently conveyed into the hand by the lever trigger.

WEIGHT

The weight of the machine is often regarded as a positive factor, particularly when grinding on horizontal surfaces. It can be troublesome when performing vertical and over-head grinding tasks, but awkward work postures of this type should be avoided in any case.

Nevertheless, if you are working on the bottom of a ship's hull, such postures are difficult to avoid.

As a general rule, our tools are designed to be as light as possible. The dynamic forces to which the operator is exposed due to the motion of the machine while grinding are small, since acceleration is low in the normal motions used.

TEMPERATURE

Low temperatures in the handles of pneumatic grinders can sometimes be annoying and are due to the expansion of compressed air in the motor.

The outlet air should be guided away from the handles. When grinding for long periods, the entire grinder housing can grow cold and the low temperature can be transmitted to the handles. These must be covered with an insulating material.

The opposite problem can occur in electrical grinders where the motor heats up during use. Machines with angle gears also have a tendency to get hot.

SHOCK REACTION

The handles of a grinding machine transmit only a small amount of jerk. When the machine is started, forces act on its distributed mass or inertia. The acceleration sequence takes about 0.5 sec. for a pneumatic machine, depending on wheel size. The operator can cope easily with the reaction force and the starting time is so long that it can hardly be considered a jerk.

For large electric machines equipped with on/off triggers, however, the operator must be prepared for the acceleration forces.

VIBRATION

The level of handle vibration for a grinder in use depends on the tool fitted. The main source is the imbalance of the wheel. A wheel that is slightly out of true will also add to the vibration value. The declared value is measured using an artificial wheel with a defined imbalance in accordance with an international standard. The vibration is often measured halfway along the length of the handle.

NOISE

The actual grinding process is the dominant noise source. A grinder driven by compressed air emits motor noise, irrespective of whether it has a vane or a turbine motor. The noise typically produced by a vane motor has a dominating frequency corresponding to the rotational speed of the motor multiplied by the number of vanes in the motor. The turbine generates broad band air stream noise. In electric tools, noise is generated by the gears and by the fan used to create the cooling air flow.

The declared value for noise in the operator's instructions is measured with the machine running free, since process noise is unique for every workplace and therefore cannot be predicted.

DUST AND OIL

Although the machine itself does not generate dust, the exhaust or cooling air whirls up a certain amount of dust. Other sources are the process and the general dust situation in the working environment.

To lower the operator's exposure to dust, a ventilated grinding booth can be used. A more efficient way is to equip the grinder with a dust collector and connect it to a spot-suction system.

Many vane motor driven grinders require lubrication and oil is added to the air inlet.



Hand-held grinding is often more flexible than using numerically controlled machines.

In machines with low outlet velocities the oil will leave the outlet in the form of drops.

A high velocity outlet atomizes the oil which is ejected as an airborne mist. How this affects the operator depends on the efficiency of the ventilation system in the workplace. One way to reduce physical exposure is to provide the air inlet with a dosol lubricator, limiting the amount of oil entering the machine. Machines driven by turbines, and electrically driven grinders, are oil free.

Drills

One of the oldest hand-held tools, drills are used in practically all industries to make holes in a variety of sizes, from less than 1 mm in diameter up to more than 50 mm. Using a drill is not regarded as a high physical risk to the operator.

Where are the tools used?

Drills are used in almost all production situations. The use of drills has changed over the years. A century ago, ships were warm-riveted. Workers expended huge amounts of physical effort drilling thousands of holes, often with diameters of more than 30 mm, to prepare the plates for riveting.

Today, holes are drilled in aircraft fuselages in preparation for riveting. However, these holes are only a few millimeters in diameter and the muscle effort required to produce them is acceptable.



Drilling is a common operation in the aerospace industry.

Working environment

In general, drills have a low impact on the working environment, particularly the small models. Large drills can be somewhat noisy. Most drills do not require lubrication.

Design for good ergonomics

The load on the operator depends on the size of the hole to be drilled. If a larger hole is to be drilled, more feed force must be applied to the machine by the operator. Larger holes can be pre-drilled to reduce the feed force.

The type of grip chosen will influence the operator's posture. A drill with a pistol grip conveys feed forces more efficiently than straight or angle grip drills.

The handle must be designed to minimize the torque absorbed by the wrist when high feed forces are needed.

The pistol grip should allow the operator to change his hold on the machine. He should hold the machine lower down the handle when applying a small feed force and higher up when high feed force is required. The high position should result in a straight line from the center line of the machine to the bones in the operator's forearm. The torque in the operator's wrist should be kept as low as possible at all times.

The straight handle should only be used when low feed forces are required,

particularly where a vertical hole is to be drilled in a workpiece. If high feed forces are necessary, a pistol grip machine may be used, provided the operator can work with his wrist held straight. If the hole requires a bent wrist posture, the position of the workpiece should be rearranged so that the operator can work with a straight wrist. The combination of bent wrist and high feed forces should always be avoided.

The angle grip is used mainly for drilling in cramped spaces. The feed force needed should preferably be applied using both hands.

The wrist's capability to provide ulnar flexion torque is limited and one-handed operation of angle drills should be avoided.

Safety

Drills are not generally a risk. However, if the operator holds the drill bit and starts the tool he will damage his hand. Some drills have a guard covering the chuck, but the drill bit cannot be guarded easily. The guard allows a comfortable two-handed grip.

When working with larger drill bits, there is always the risk of a jerk when the drill bit penetrates the workpiece, resulting in a shock reaction which is absorbed by the operator's wrist. Most of the feed force is applied to the point of the bit to help it work

its way through the material. When the point penetrates, the operator should reduce the feed force. If the drilling cycle does not allow time for this, the drill bit will not cut a clean hole and may jam. Problems of this kind can be avoided by using a support handle.

HANDLE DESIGN

The pistol grip for drills was the first grip designed using the human anatomy as a basic criterion. The angle of the handle to the center line of the machine was chosen so that the operator could keep his wrist straight when holding the tool. The torque absorbed by the wrist from the feed force should be kept to a minimum. The handle should be long enough to accommodate the entire hand. The handle width was selected so that the fingertips almost reached the base of the thumb when the operator grasped the tool tightly.

EXTERNAL LOAD

Feed forces are the greatest load factor when drilling. Machines designed for large diameter bits are provided with planetary gears. These add weight to the tool, moving the center of gravity away from the operator's wrist and increasing the radial flexion torque. This is a design dilemma. The operator needs to grasp the handle high up in

order to minimize the wrist torque from the feed force. A pistol grip which allows this is a good choice. At the same time, a pistol grip with the handle at the end of the tool will transmit torque to the wrist due to the weight of the machine.

WEIGHT

As mentioned previously, weight causes torque to be transmitted to the wrist. The operator is exposed to this factor when he moves the tool to and from the workpiece. To solve this problem, the tool is often suspended in a balancer which, particularly in the case of COL type balancers, renders the machine virtually weightless. Thus, at a typical workstation, the weight of the tool does not expose the operator to dynamic forces.

TEMPERATURE

The exhaust air from the vane motor is cold but, since the air flow is directed away from the hands, this causes no discomfort to the operator. The temperature of the actual machine is proportional to the power it uses and in most applications the drill has a greater power capacity than it needs to cover short power peaks. Thus, the machine does not become cold enough to cause operator discomfort.

SHOCK REACTION

Sudden changes in torque from the machine can occur when the drill bit penetrates the workpiece. These torque peaks cannot be fully predicted and the best way to combat the problem is to use a support handle.

VIBRATION

In drills vibration levels are low, in general below 2.5 m/s^2 . The vibrations are measured in a process where holes are drilled in a piece of metal, as defined in ISO 28927-5. If a bent drill bit is used, however, the vibration can be considerable.

NOISE

In most cases, the drilling process itself is not noisy. Therefore the level of noise to which the operator is exposed is the declared noise level according to the definition of the work situation provided by the noise measurement code.

DUST AND OIL

Drilling is a cutting process which produces long chips and, since these will not usually be airborne, no dust is created. However, when drilling in composite materials, such as carbon-reinforced plastic, the operation can result in minute airborne carbon fibers.



A small, modern drill must be designed to give the operator a choice between high and low grip.

These can penetrate electronic equipment and cause short-circuiting.

This problem can be solved by equipping the machine with a dust collector connected to a spot suction system. Most drills are designed to run without lubrication.

Percussive tools

Percussive tools use the blow energy from an accelerated piston to create high forces. The high forces can be used to chip off steel or to set a rivet. Using the tool may, however, involve risk of injury from noise and vibration.



Vibration controlled riveting hammers and bucking bars are frequently used in the aerospace industry.

Where are the tools used?

There are three different types of percussive tools: chipping hammers, scalers, and riveting hammers. The first two are commonly used in foundries, while the riveting hammer is mainly used in the aerospace industry. Since percussive tools are very effective they are commonly used for a variety of other applications, from the worker assembling guide pins in engine blocks to the sculptor chipping away at raw material in his studio.

Working environment

High noise levels are a typical problem with percussive tools. The machine noise can be muffled, but noise from the main source, the process, is difficult to reduce in a way that is physically acceptable to the operators.

Vibration values are also high for percussive tools, in particular from the inserted tool. There is a general rule that the chisel in a chipping hammer, for example, should not be touched when the tool is being operated. Easy to say, but difficult in

practice. Sometimes the chisel has a round neck and the operator needs to guide it manually. Technically, this is to make the blow end flexible when cleaning a casting. From the point of view of safety, it is not good practice.

Design for good ergonomics

Modern machines are provided with mufflers. When carrying out light cleaning of sand burnings on castings, the efficiency of the muffler can make a difference, but usually the process noise dominates.

Control of vibrations in percussive tools has been more successful. Several methods have been used – for example, reducing the oscillating forces acting on the machine mass, or designing an isolation system which screens off the operator from the vibrating tool.

For chipping hammers, where the process calls for high feed forces, the bow grip handle is often used to minimize the torque absorbed by the wrist. The trigger force and the feed force are in alignment and the trigger is often thumb-operated.

When using percussive tools, the working posture often remains the same for long periods of time. This may lead to muscle overload and fatigue due to static forces acting on the hand-arm system.

Safety protection

Ear defenders, safety goggles and gloves are strongly recommended. Research is continuously being conducted into the development of anti-vibration gloves. At present such gloves are ineffective against the low frequency vibrations emitted by these tools. Operators working in heavy industry should wear protective headgear.

To prevent the operator from holding the chisel, the machines are provided with a retainer and, in many cases, a hand grip that can be moved along the chisel.

HANDLE DESIGN

The open or closed bow grip, or D handle, is a typical feature of chipping hammers. Riveting hammers and scalers often have straight or pistol grips. Chipping hammer handles are designed to allow high feed forces to be applied for long periods. The trigger is thumb-operated and the trigger force is in alignment with the feed force. Riveting hammers are designed for high precision and, in principle, one working posture. The trigger function on these tools allows one-blow-per-cycle operation.

EXTERNAL LOAD

During a chipping operation high feed forces may be needed, while the posture often

remains the same. This loads the muscles of the upper arm with static forces. Undamped tools have high vibration values, causing greater tension of the muscles and increasing the percentage of maximum voluntary constriction (MVC). Scalers and riveting hammers require only low or moderate feed force and, even used for long periods, scalers represent a low level of physical exposure for the operator. As regards riveting hammers with higher feed forces, the total exposure per day is less than 20 minutes, therefore physical exposure is low.

WEIGHT

Tool weight is often a positive factor since it keeps the vibration value low and contributes to the feed force. Percussive tools are moved so slowly that they do not expose the operator to any dynamic forces.

TEMPERATURE

Percussive tools are full-pressure machines. In other words, there is very little expansion of the compressed air in the cylinders. Therefore the temperature of the machine does not fall low enough to cause operator discomfort. On the other hand, if a chipping hammer is used for long periods, the chisel will become hot to the touch. But, as stated before, the operator should not hold the chisel in any case.



Scalers are commonly used in welding operations.

SHOCK REACTION

These tools do not give any shock reaction.

VIBRATION

There are at least three sources of vibration in a percussive tool: the oscillating force that drives the piston, the shock wave transmitted to the machine from the chisel, and the vibration of the workpiece transmitted back to the machine. These sources can be counteracted at the design stage as described in the chapter *Evaluation of Power Tools: Vibration*.

NOISE

The basic principle of percussive tools is to create a shock wave that travels down the chisel or die to strike the casting or rivet with enough force to cause plastic deformation. The shock wave has a duration of less than 100 μ s. This process involves very high frequencies and when these hit a structure many natural frequencies are excited, emitting broad band noise. High forces give high noise levels.

DUST AND OIL

Chipping and rust cleaning can create a lot of dust. In other words, the operator's exposure to dust depends very much on the type of work in progress. The machine can be equipped with a dust collector connected to a spot-suction system.

Percussive tools require very little lubrication since the piston moves back and forth in a very smooth cylinder without generating heat. Only a minimal amount of oil leaves the tool with the exhaust air.

Screwdrivers

Screwdrivers are used for the assembly of a variety of products, such as dishwashers, refrigerators, washing machines, electronic equipment and medical instruments, to name just a few. A clean indoor environment, careful selection of hand tools and ergonomically designed workstations will result in a low level of physical risk for the workers, provided that the work is organized to avoid frequent repetition.



For modern pistol grip screwdrivers, the air inlet can be located on the top of the tool to simplify installation in balancers.

Where are the tools used?

Screwdrivers are used to assemble parts in designs where the products need to be dismantled easily for repair and service. A typical assembly operation could be mass production of a DVD player on an assembly line where a few screws are tightened at each workstation. It could also be the total assembly of a food processor by one operator. Consumer goods have relatively short life-cycles and new products are regularly introduced into the production plant. This gives method engineers the chance to correct earlier mistakes in workplace design.

Working environment

Modern products are often produced in good working environments with adequate lighting and good ventilation. However, while environmental problems are limited, other problems may arise. For example, many operators, particularly females, suffer from work-related musculoskeletal disorders, in particular in the upper limb, neck and shoulder area. Although not always physically

heavy, assembly work is often highly repetitive. Work organization and workstation design are therefore very important.

Design for good ergonomics

For the operator performing repetitive tasks, maintaining a correct posture is of great importance. The location of joints and the selection of machine type must be considered. Screwdrivers are available in straight or pistol grip versions. Working postures with the wrist in a natural position are preferred.

Modern straight tools have a textured surface that increases the friction between the tool and the hand. This enables the operator to hold the machine without excessive effort. Since the tools are usually light and the tightening operation tends to make them rotate in the hand, the operator absorbs the reaction torque at the end of the tightening sequence. The magnitude of this kind of shock reaction is related to the type of joint and the function of the tool. With hard joints and pneumatic tools with a fast clutch, the tendency of the tool to rotate in the operator's hand, caused by the impulse, is low.

Electric screwdrivers, on the other hand, can be controlled so that the operator experiences almost the same torque reaction, independent of joint stiffness. Thus, the

muscles in the operator's arm are more relaxed. For this reason, many vehicle assembly plants permit a higher torque before torque reaction supports are required for electric tools than for pneumatic tools.

Screwdrivers often have a push-to-start trigger function. Thus, the tool starts itself when the bit is pressed against the screw. Different screw heads require different amounts of force to keep the bit in place. Therefore the screw must be selected with care to avoid excess load on the operator.

Safety

Most screwdrivers are low-powered tools and represent a low safety risk to the operator. As regards pneumatic tools in the upper torque range, however, if the clutch is wrongly adjusted, it may fail to disengage at the end of the tightening sequence. Therefore the clutch must always be tested before the tool is installed at a workstation.

The air pressure along the assembly line must be controlled and sudden pressure drops must be avoided. If a pressure drop occurs during tightening, the torque from the motor may not be strong enough to disengage the clutch and the operator might be forced to absorb the reaction torque without any previous warning. This may cause wrist problems.

HANDLE DESIGN

Most screwdrivers are provided with either a straight or a pistol grip. The surface of the handle has a rough texture to prevent it from rotating in the hand due to the reaction torque when tightening.

This increases the friction between the handle and the hand. When push force is required (for certain screws), a handle end-stop is recommended if a straight machine is used. However, the best choice for high push forces is the pistol grip.

Straight screwdrivers usually have a lever trigger or a push-to-start function. If the tool has a reverse function, it is often controlled by a thumb-operated button.

By gripping a pistol grip tool with the entire hand, the operator can cope with higher torque levels than when using straight machines. The finger-operated trigger and thumb-operated reverse function are common designs.

EXTERNAL LOAD

Straight machines must be grasped tightly to counteract the reaction torque. This problem can be solved by a torque reaction arm.

Self-drilling and self-tapping screws require high push force. When using screws of this type, the repetitiveness of the task must be considered.

Screwdrivers are often used for assembly tasks at sitting workstations. In the sitting position, the neck and shoulder muscles can easily be overloaded, particularly when performing highly repetitive tasks.

WEIGHT

Screwdrivers are relatively light, low-powered tools. At a typical assembly station they are hung from balancers. These must be adjusted so that the operator does not need to use excessive force to pull the tool down. When performing highly repetitive tasks the weight of the tool may place an additional external load on the operator, but repetition should be avoided wherever possible.

TEMPERATURE

Screwdrivers consume energy for limited periods only. Therefore low or high temperatures are not a problem in most applications.

SHOCK REACTION

A short period of increased torque when tightening a screw will cause a straight tool to start rotating and a pistol grip tool to turn. The magnitude of the motion depends on the impulse. The fastest machine capable of generating the torque needed for the joint should always be used in order to minimize the impulse. The motion of the tool also

depends on its inertia. The same impulse will have a greater turning effect on a straight tool than on a pistol grip tool.

VIBRATION

There are two types of screwdriver. The shut-off type and the slip clutch type. Shut-off tools have very short operating cycles. The pulse from tightening with a shut-off tool cannot be regarded as a vibration. Slip clutch tools, on the other hand, continue to run until the operator releases the trigger. Operators tend to run the tools with the clutch slipping for a few seconds on each joint. This behavior will expose the operator to unnecessary vibration.

NOISE

These tools are often used in low noise assembly areas. Therefore, low machine noise is important to avoid disturbing workers' conversation or enjoyment of radio broadcasts. Another reason for keeping noise levels to a minimum is the fact that an operator performing a precision task often works with his head close to the tool.

A muffler is used for noise control on pneumatic tools and the exhaust air is often piped away from the machine in an exhaust hose. Electric screwdrivers normally have very low noise emissions.

DUST AND OIL

Dust is not created in the process and the tool is lubrication free.



Electric screwdrivers can be programmed to tighten the joint to the correct torque with a minimum of reaction torque to the operator.

Impact and impulse nutrunners

One of the first hand-held power tools developed for nut-running, the impact wrench was in common use in the automotive industry until the early 1970's. During this decade, it was gradually replaced by the shut-off, stall-type nutrunner, a less noisy and more accurate tool. The 1980's heralded the arrival of the impulse nutrunner. Offering lower noise levels and higher accuracy than the impact nutrunner and less reaction force than the stall-type nutrunners, the pulse machine now has a rapidly growing share of the market.

Where are the tools used?

Nowadays, impact wrenches are used in after-sales service applications, such as car repair shops. The main advantage of impact wrenches is their capability to unscrew rusty



With the introduction of shut-off pulse tools with torque measurement capability, the accuracy of pulse tools has dramatically increased.

bolts. Unfortunately there are a lot of these in old cars. Another advantage of these tools is their small size in relation to their torque level. The tools are often used on huge constructions such as skyscrapers and bridges.

Although they generate very high torque, they are relatively light and compact and can therefore be carried around a crowded building site without too much difficulty.

Instead of the traditional mechanical blow provided by impact wrenches, impulse nutrunners incorporate a blow mechanism which converts the rotational energy into blow energy to the joint via a hydraulic cushion. Although these tools have a lower torque-to-weight ratio than impact wrenches, they offer other advantages. They are increasingly found in applications where impact wrenches were traditionally used in the sixties. In other words, in a different kind of line production.

Working environment

Impact and impulse tools can be found in all working environments. From a one-man repair operation on an earth floor, to the most up-to-date production facilities in the world. The impact wrench adds process noise to the environment.

In a vehicle repair shop, the impact wrench is often used in an overhead posture.

The car is lifted and the mechanic works from below. The location of joints often means that the tool must approach the joint from different angles. In this case, it is important to align the center line of the tool with the direction of the joint. Otherwise, each blow may cause the tool to jump, creating low frequency vibration which is transmitted to the entire hand-arm system.

Design for good ergonomics

If the operator is working with a bent wrist, there is a risk that the median nerve passing through the carpal tunnel will be affected, leading to numbness in the thumb and index finger.

Feed forces are usually low. On heavier impact wrenches the handle is located under the machine to minimize the bending torque on the operator's wrist. Such tools are often provided with a suspension device which allows the operator to work with the machine tilted. This also gives better access to the joint and the operator can perform the task without exposing his wrist to rotational torque.

Safety

The socket should always be locked to the spindle. These tools often have a high free running speed and a loose socket could fly off and cause a serious accident.

The socket must be of high quality to avoid small pieces working loose and causing an accident. Worn-out sockets should be replaced.

HANDLE DESIGN

The handles of nutrunners are quite complicated. They contain an air inlet, a trigger function, a reverse function and an air exhaust, which also incorporates a noise muffler.

If the handle size is reduced, the amount of space for noise control is also reduced and the noise level will be higher.

EXTERNAL LOAD

Reaction forces are low and rotational torque is low during tightening. The distance between the center of gravity and the wrist can result in a bending torque in the wrist if the tool is used in an upright position. If the tool is tilted, this distance can cause a combination of a bending and a rotational torque in the wrist. Suspension of the machine is strongly recommended.

WEIGHT

In these tools, the weight factor is responsible for most of the physical load on the operator, particularly if the machine is not suspended. On the other hand, there is no other machine type on the market today

with a higher capacity-to-weight ratio. Weight can cause static load and, if the work cycle is highly repetitive, the additional load from the motion of the tool can be considerable.

TEMPERATURE

High or low temperatures are not a problem when using these tools. Since they are used for a short time only during each tightening cycle, the cold exhaust air from the motor does not have time to make the handle uncomfortably cold.

When highly repetitive work is carried out with an impulse tool, the front end of the tool where the blow mechanism is situated, can become warm. However, it is unlikely that the temperature will increase to such a degree that it will cause operator discomfort.

SHOCK REACTION

Impact and impulse nutrunners produce no shock reaction.

VIBRATION

The oscillating forces that can cause the machine housing to start vibrating are not high, particularly in modern percussion mechanisms. The motor itself accelerates from zero revolutions to full speed between each blow. This creates an oscillating re-



The low reaction torque in impulse tools means that straight tools can be used without torque arms for applications requiring torque up to 50 Nm.

action torque on the machine housing which results in vibration. The magnitude of this vibration depends on the machine inertia and the length of the blow. At the end of each blow, the motor exerts maximum torque on the machine housing. The modern shut-off tool types are preferred from a vibration point of view. The tightening time is reduced to a minimum which, in turn, minimizes operator exposure to vibration.

NOISE

The muffler in these machines is most effective during free running or run-down of the nut. The air flow through the muffler is then at maximum, giving a pressure drop in the outlet of the muffler. During tightening, the noise from the process is greater than the noise from the tool. The impulse machine has far lower noise levels than the impact machine.

DUST AND OIL

Dust from the process is very rare and most machines are lubrication free.

Angle nutrunners

Angle nutrunners are used at assembly workstations for repetitive assembly of joints. Both pneumatic and electric versions are available. They should preferably be used in a two-handed grip to avoid excessive wrist torque. Angle nutrunners are accurate and give low noise levels in operation.

Where are the tools used?

Developed during the 1970's angle nutrunners replaced impact wrenches in many plants. They are more accurate and quieter than impact wrenches. Since they are stall-type machines, there is no process noise. Installed in automotive plants for assembly line work, the early tools were designed to stall at the end of the tightening process. The operator had to apply a force at the handle equal to the installed torque divided by the length of the machine. Sometimes this could be annoying for the operator, if the joint was



Angle nutrunners are widely used on assembly lines today.

in a less accessible location. Typically, these machines should be used in a two-handed grip. The center of gravity is about halfway along the length of the machine, transmitting a high torque to the operator's wrist if the machine is operated with only one hand.

The working environment

A typical automotive plant in the 1970's was a noisy place. Conveyors, hydraulic pumps and other sources generated a general noise level of around 85 dB(A). The reverberating field of the workplace was not treated acoustically. Fortunately for the physical well-being of the personnel, hand power tools and other installations have improved continuously over the years. Today, the general noise level is usually about 80 dB(A). The hand tools are not used for long periods each day and thus do not add much to that level. Another noise source (or sound source depending on the listener) which has become commonplace is music from radios, and this can be annoyingly high.

Nowadays, assembly line production is quite complicated, as are the products. Increased demands on quality are motivating investments in more sophisticated equipment. As the new installations are also better from an ergonomic viewpoint, this trend is resulting in a gradual improvement of the working environment.

Design for good ergonomics

The most important parameter for angle nutrunners is the shock reaction in the trigger handle at the end of the tightening process. Attempts to eliminate this problem by

design have taken two different paths – one for pneumatic tools and one for electric tools.

The level of shock reaction depends on the forces acting on the machine during the tightening cycle. A reaction torque from the tightening process tends to rotate the tool. The rotation causes a sharp jerk in the handle.

To counteract this in pneumatic tools, a very fast clutch has been designed which minimizes the shock reaction and, consequently, the jerk.

In electric tools, socket speed can be controlled easily, therefore it has been possible to increase and decrease the socket speed in such a way that the operator does not experience it as a shock.

Safety

When using angle nutrunners, there is a risk of crushing or severing the fingers. If the torque is higher than 60 Nm, a reaction bar is recommended. Since this increases the weight of the tool, the decision to use the reaction bar depends on the location of the joint, i.e., the operator may decide not to use a reaction bar if the location of the joint means that he has to support the weight of the tool in an awkward posture.

High torque, pneumatic angle nutrunners are fitted with a pressure valve which disconnects the tool from the air-line if the

pressure drops below a preset value. This precaution ensures that the pneumatic motor can always release the clutch and prevent an unexpected jerk in the handle.

HANDLE DESIGN

The trigger handle on an angle nutrunner is usually round in shape, with a diameter of 38 mm and a length of 100 mm.

Pneumatic tools have lever triggers, while electric tools are fitted with small switches that can be operated with one or two fingers.

EXTERNAL LOAD

Use of these machines exposes the operator to two main load factors. One is the torque reaction transmitted through the handle, the other is the weight of the machine acting on the operator's wrist. (For torque reaction, see "shock reaction" below.)

The tool's slim, elongated design places the centre of gravity about halfway along its length. If one hand is used to lift the tool from the support to the joint, the operator's wrist will be exposed to a rotational or bending torque. This can be avoided by lifting the tool with both hands. Conventional tools for torque higher than 20 Nm will load a female operator to more than 30% of MVC for the wrist, when lifted with one hand.

In the design of modern tools consider-

able efforts have been made to reduce overall weight and to move the center of gravity closer to the handle. Modern tools in sizes for torque up to 40 Nm can be lifted with one hand before the load on a female operator will reach 30% of MVC for the wrist.

Tightening should preferably be performed using a two-handed grip, with one hand on the handle and the other as close to the angle head as possible. However, the operator will quite often have to use his or her non-trigger hand to introduce a bolt or nut to the joint.

When an angle nutrunner is used with only one hand, the operator's torque handling capability is greatly reduced. When a tool is used with one hand and with an extension between the tool and the socket, it is good practice to use the same values for the torque handling capability as for a pistol grip tool.

WEIGHT

The external load on the wrist may increase due to the motion of the machine. Highly repetitive work cycles must be avoided.

TEMPERATURE

In pneumatic tools low temperature is not a problem since they are normally used for short periods only. In the case of electric



Today, the angle nutrunner can be equipped with various accessories, such as bar code readers, to reduce the number of items to be handled by the operator.

tools in intense use, high temperatures have caused problems in the past. The advent of modern, high-efficiency motors brought the solution.

SHOCK REACTION

The term shock (or torque) reaction describes what happens to the machine and the hand gripping the handle during the tightening sequence. The operator experiences the motion of the handle as a shock only if it lasts for less than 300 ms. If tightening takes more than 300 ms, the operator will have time to increase the force on the handle of the tool and counteract the reaction torque. Thus, he will not experience a shock reaction.

The magnitude of the shock reaction, or jerk, depends on the stiffness of the joint and the spindle speed. Torque as a function of time gives the impulse that accelerates (rotates) the machine – the shorter the impulse, the smaller the resulting shock reaction in the handle of the tool. With hard joints and fast clutches, the operator needs to apply light force only at the trigger handle and the inertia of the machine will absorb the shock reaction.

VIBRATION

The declared vibration value for angle nut-runners is $<2.5 \text{ m/s}^2$.

NOISE

Declared noise levels for electric tools are below 70 dB(A), and below 80 dB(A) for pneumatic tools. Angle nutrunners generate no process noise and, since they are not operated for prolonged periods during one day, they do not cause any significant increase in the noise level at the workplace. Electric tools have even been criticized for being too silent. Sometimes the operators do not get sufficient acoustic feedback when using the tool to judge the progress of the tightening cycle.

DUST AND OIL

These factors are not an operating problem for pneumatic or electric tools.



Modern angle nutrunners are increasingly used in the aerospace industry.

High torque nutrunners for use with reaction bars

High torque nutrunners need a reaction bar to handle the reaction torque when tightening a joint. Since the bar is tailored to a specific joint, tools of this type are mainly used in assembly line production. In this group we include electric nutrunners and stall-type pneumatic nutrunners designed for use with reaction bars or articulating arms to handle high torque applications.

Where are the tools used?

A typical application for high torque nutrunners is in the automotive industry. Installed torques vary from 100 to 4,000 Nm, and sometimes even higher, depending on tool size. Larger tools are mainly used in the

A high torque pistol grip nutrunner can tighten large bolts without placing too much load on the operator.



production of heavy vehicles such as trucks, buses and off-road vehicles.

The working environment

The high torque nutrunner is usually preferred in modern industrial situations as it contributes to a good working environment. The workstation can be stationary or on a moving line. The tool has virtually no negative impact on the working environment. Weight can be a negative factor for the operator, therefore in most applications the tools are suspended from balancers.

Design for good ergonomics

During the 1970's, production engineers tried to replace impact wrenches with stall-type nutrunners in order to reduce noise and improve accuracy. However, operators complained of the increased tightening times (about three times longer than impact wrenches). This was particularly noticeable in assembly line production where the entire balance of the line was changed.

A popular solution was a new tool design incorporating two motors – a fast motor for rapid nut run-down and an additional, slower motor for the final tightening sequence.

Tools with reaction bars are heavier than conventional tools. This must be considered in tool installation, for example, using balancers or articulating arms.

Safety

The major safety risk in operating these machines is pinching, crushing, or severing of the fingers. The forces acting between the reaction bar and the workpiece are considerable and could easily sever a finger. Thus, all machines carry a warning label: “Never hold the reaction bar while tightening”.

HANDLE DESIGN

Small machines usually have pistol grips. Larger tools tend to be front-heavy due to the extra gears required. A handle placed under the machine, as near to the center of gravity as possible, minimizes operator discomfort.

EXTERNAL LOAD

High torque nutrunners are heavy and should therefore be suspended from balancers. During tightening, the reaction forces are absorbed by the reaction bar instead of the handle. The reaction bar may make the tool front-heavy, thus exposing the operator's wrist to bending torque.

WEIGHT

A high-torque machine, equipped with transducers for measuring torque and angle, is a heavy tool, therefore an articulating arm is recommended. Since the larger machines



Wheel nuts on trucks and buses are a typical application for high torque nutrunners.

are not used for highly repetitive tasks, the operator is not exposed to high dynamic forces from the motion of the machine.

TEMPERATURE

These tools do not pose a temperature problem.

SHOCK REACTION

The reaction bar eliminates the shock reaction in the handle.

VIBRATION

Declared vibration values are $<2.5 \text{ m/s}^2$.

NOISE

Process noise is non-existent and the tools have declared noise levels below 80 dB(A).

DUST AND OIL

The process does not generate dust. Some oil is present in the exhaust air but operator exposure to oil will be low due to the limited duration of usage.



3

EVALUATION OF POWER TOOLS

Introduction

A basic ergonomic principle when designing a hand-held power tool is that operation should be easy and involve no risk of damage to the health of the operator or to the immediate environment. A poorly designed tool poses a number of potential risks.

The wrong type of handle may have been chosen in relation to the workstation and/or the task to be performed. This can lead to awkward working postures and reduced operator capacity in terms of muscular strength.

The physical characteristics of the operator may not have been fully taken into consideration. Thus, the size or shape of the hand tool may cause excessive local pressures to be applied to the blood vessels and nerves of the hand, resulting in musculoskeletal symptoms. These factors are discussed in the chapter entitled *Handle Design*.

The undeniable advantages of powerful hand tools in many industrial situations may sometimes be a distinct disadvantage for the operators. The reactive force or torque generated by such powerful tools may well be beyond the limit that an operator can withstand without sustaining physiological injury.

Holding heavy tools subjects the upper extremities to continuous load and applies static load to certain musculoskeletal structures. The vibration caused by a conventional percussive tool may be very uncomfortable for the operator and cause damage to the neuro-vascular system of the hand in the form of, for example, white finger syndrome. The chapters *External Load*, *Weight*, *Shock Reaction*, and *Vibration* cover these factors.

The motors of hand-held tools may cause contact surfaces to become extremely hot or cold. Noise, dust and oil not only influence the health of the operator but also the working environment. Ergonomic considerations relating to these risk factors are described in the chapters *Temperature*, *Noise* and *Dust and Oil*.

As ergonomics is still a relatively young science, many of the risk factors mentioned above require further study in order to determine the quantitative relationship between operator exposure and the subsequent effect on the health of the person concerned.

The evaluation method presented in this chapter can be applied to find the best tool

for a specific application. Also, in situations where power tools are used, it can be used to evaluate the effect of redesigning a workplace.

The evaluation method can serve as a powerful aid in the struggle to find the best possible combination of ergonomic factors.

Since the first edition of this book was published we have seen many examples of how this evaluation method is used by large companies to assist them in choosing power tools from an ergonomic standpoint.

Fig. 3.1 The tool should be a natural extension of the hand.

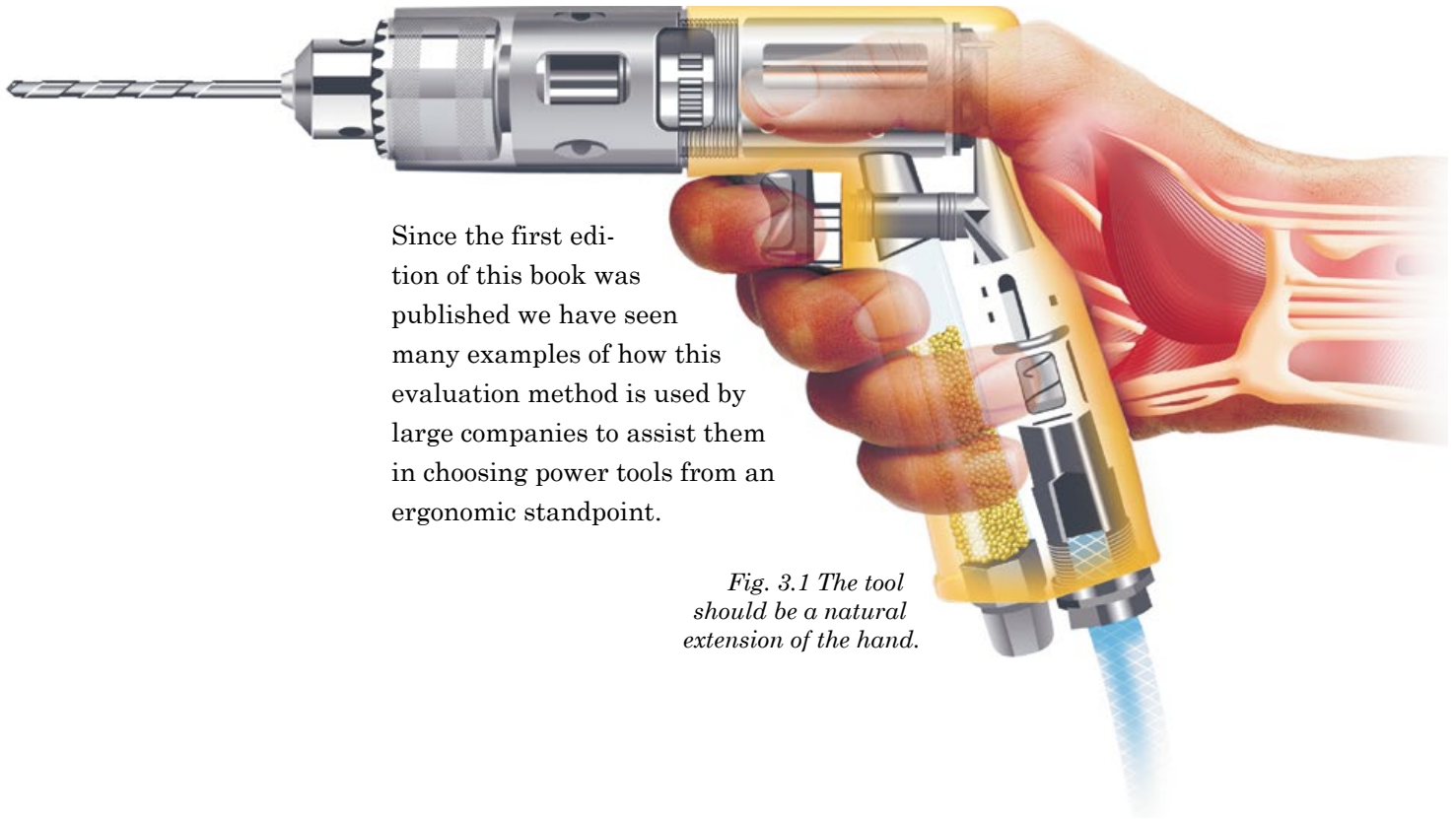

Handle design

The handle of a hand tool is the part that has most direct contact with the hand or hands of the operator. Thus, handle design directly affects the usability and comfort level of the tool during operation. From an ergonomic

viewpoint, the aim is to design handles which allow the operator to apply maximum force and grip. Good handle design also results in natural working postures and eliminates harmful local stresses on the operator's hands.



The advantages and disadvantages of each basic handle type depend on the actual machine, the work it is designed to do, and the workstation at which it will be used. When a machine is installed at a workstation, the choice of handle depends on the various combinations of work surface heights and the amount of force which needs to be applied for the tasks to be performed.

Working postures are an important guide in the selection of tool handle. Special consideration should be given to the hands,

shoulder, and upper arms. The hand and forearm should always be aligned when force is being applied.

If the shape of a tool causes extreme hand postures, the operator will often compensate by raising an arm, or elevating a shoulder.

The torque exerted on the shoulder is governed by the angle of elevation of the upper arm. Therefore this angle should generally be limited to less than 20 degrees when a tool is in continuous operation, in order to reduce stress on the shoulder muscles.

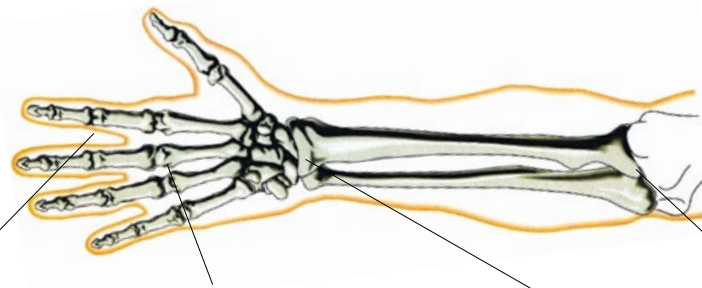

Problem Cause	Deformation of joints Repeated external loads over a long period of time.	Bursitis Inflammation of a fluid filled sac (bursa) serving as a cushion to protect the tendons from the bony ridge.	Inflammation in joint capsules Repeated load may dry out the synovial fluid that lubricates the joints.	Arthritis Repeated use of arms in extreme postures, shocks and repeated arm rotations.
Symptom	Decreased joint mobility, aches and pains.	Pain from the inflamed bursa.	Pain during movement.	Worn-out joints, decreased mobility, increased stiffness and pain during activities.
Ergonomics	Tools with high push forces should be designed in a way that enables the hands to be held in neutral posture.	Reducing the forces and movements and avoiding uncomfortable hand and arm postures.	Designing tools and workstations that allow variation in postures and less external loads.	Decreasing forces, Improving work, reducing or eliminating shocks and vibrations.

- Arteries
- Veins (superficial)
- Veins (deep)
- Nerves (superficial)
- Nerves (deep)

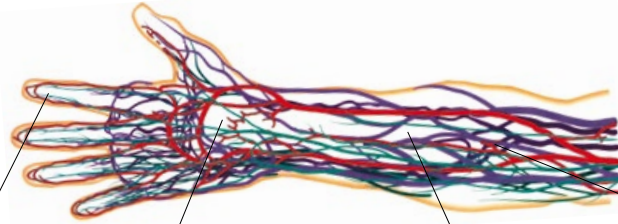

Problem	Damage of finger nerves and blood vessels	Compression of the median nerve	Decreased blood circulation	Compression of nerves and blood vessels between the neck and the shoulder
Cause	High local forces, and vibrations.	Bent wrist and high finger forces. Pinched grip. Repetitive work.	Cold handles, and handles that are too small.	Work that requires frequent reaching above shoulder level.
Symptom	Tingling and numbness in the fingers.	Pain and numbness in the hand, ache in the arm.	Numbness in the hand and ache in the arm.	Numbness in the fingers. The arms may feel as if they are "going to sleep"; and the pulse in the wrist may weaken.
Ergonomics	Avoiding sharp edges and reduction of vibrations.	Avoiding bent wrist.	Improving insulation. Better handle design.	Improving workstation design to reduce frequent reaching above shoulder level.

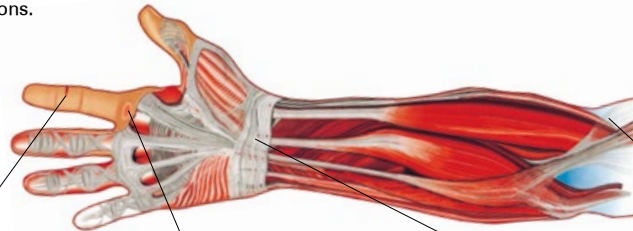

Problem	Cuts	Sores and calluses	Carpal tunnel syndrome	Tennis elbow
Cause	Sharp edges. Unguarded inserted tools.	High friction forces and pressure on a spot in the hand. Pinch damages.	Highly repetitive high grip force with bent wrist.	Overload and inflammation of the tendon attachment in the elbow (lateral epicondylitis).
Symptom	Bleeding and risk of infection.	Fluid between skin layers and local increased thickness of the skin. Pressure on the median nerve in the carpal tunnel.	Numbness of the thumb and index finger due to pressure on the median nerve in the carpal tunnel.	Pain in the elbow and down in the forearm.
Ergonomics	Better guards. Warnings.	Improving the texture of handles to provide sufficient friction on the handles and increased contact surface. No pinching from triggers.	Workstation design and the selection of tool to permit the operator to work with a straight wrist.	Reducing the need for squeeze forces and lift with the palm of the hand facing the floor (wrist extension).

The hand-arm system

The structure of the hand-arm system is extremely complex. Highly repetitive work tasks in combination with bad postures and external loads can cause work-related musculoskeletal disorder (WRMSD). Depending on the work situation, WRMSD can develop in different parts of the hand-arm system.

In choosing the tool handle and planning the workstation, one should always aim at achieving a work posture with a straight wrist. Several tendons and the median nerve pass through a narrow tunnel (the carpal tunnel) in the wrist. In extreme hand positions, the nerve and tendons are compressed. Such postures often result in symptoms of damage to the hand, such as carpal tunnel syndrome (CTS).

A pistol handle is, therefore, often designed with an angle of 70 degrees in relation to the longitudinal axis of the tool. A pistol handle is also preferred for tasks

requiring both power and precision. The reason is that the hand grips a pistol handle in a combination of a “power grip” (the hand is wrapped around the handle) and a “precision grip” (such as holding a pencil).

The pressure contact area of the handle should be the fat pads of the hand. Excessive pressure on the fingers may damage the neurovascular bundles on either side of the fingers. They lack protection and are susceptible to trauma.

The center of the palm is also poorly designed to withstand the application of direct force. This is due to the existence of sensitive anatomical structures underneath, i.e., the median nerve, arteries and synovium for the finger flexor tendons.

Sharp edges on the handle should be avoided in all cases. Form-fitting handles should also be avoided. They may look as though they were molded to the hand, but they are only molded to one particular hand.

Our fingers differ in strength. The middle finger is the strongest and the little finger the weakest. The force-generating capacity of the index, middle, ring and little fingers is, on average, about 21%, 34%, 27% and 18%, respectively. Therefore, when designing or locating a trigger, for example, the greater force-generating capacity of the stronger fingers can be used to full advantage.

Power grip



Precision grip



Fig. 3.2 Examples of power and precision grips.

Handle size

Since a tool handle usually houses a number of functions, such as an air inlet, a trigger and reverse control, a noise muffler and an outlet valve, handle design must always be a compromise.

For instance, if the designer wishes to reduce the circumference of the handle, the volume of the noise muffler must also be reduced, with increased noise levels as a result.

The length of the handle

As mentioned earlier, the fingers and center of the palm are sensitive to high pressure. Therefore the handle should be sufficiently large to distribute the forces in play over the palm and across the fingers.

Studies of the breadth of male and female hands indicate that the palmar force-bearing area should be at least 90 mm long to ensure that palmar forces are primarily supported by the muscles on each side of the palm. A general recommendation for the handle length of tools where appreciable forces are to be applied is about 100 to 130 mm.

When high accessibility is important, the lower end of the size range may be preferred. If a tool is specifically intended for female operators, a shorter handle length may be selected. The optimal handle length

for female operators is about 90 to 110 mm and no shorter than 80 mm. When tools are used with gloves, an additional 10 mm should be added.

Handle diameter

Handle diameter is the main factor influencing the operator's capacity to generate force. When grasping a large tool handle, the force applied from the fingertips can be two or three times greater than the force applied from the inner part of the fingers. On the other hand, if an object is too small, the fingers cannot effectively apply force to it, partly because the finger flexor muscles are foreshortened and lose their contractile capability to produce tension. For circular handles the following dimensions are recommended:

- **Power grips:** recommended diameter of 38 mm for men and 34 mm for women; acceptable range from 30 to 45 mm;
- **Precision operations:** recommended diameter of 12 mm; acceptable range from 8 to 16 mm.

Straight screwdrivers may be given a conical form. The operator can select different positions on the handle and in that way change the diameter depending on the type of work to be performed. An end stop is a



A modern screwdriver has a handle with a viscoelastic grip and a pronounced stop to reduce the grip force.

good option if the operator prefers to place the hand near the end of the machine. The LUM is a good example.

Contact surface

The surface between the handle and the hand that exerts force must not be too

small, because that can cause pain. A rule of thumb is that the skin surface pressure should not exceed 20 N/cm^2 .

Material and texture of handles

Handles should provide efficient electrical and heat insulation. Compound rubber and plastic are efficient heat insulators and, in some situations, good electrical insulators.

Some power tools include heat or cold sources which can cause injury to the operator's hands. The selection of heat insulation material is therefore particularly important in their design.

Handle materials should also be hard enough to avoid work particles or dirt becoming embedded in the gripping surface. This is particularly important for machines which produce dust particles during operation, such as grinders.

To ensure a good grip on a handle, sufficient friction must exist between the hand and the handle surface. This is particularly important where large amounts of force are to be applied and when the hand may be sweating.

Different materials and texture patterns provide varying degrees of friction.

Textured rubber handles usually provide sufficient friction for a good grip and can reduce muscle effort during tool operation.

However, if the texture is too coarse the skin becomes irritated and operating efficiency is impaired. A correctly textured handle reduces the risk of the tool slipping out of the operator's grasp and reduces energy expenditure to a minimum.

Glossy surface coatings or highly polished surfaces should be avoided.

Today Atlas Copco uses a common type of textured rubber on all handles. The texture has been carefully chosen to provide good friction under all conditions. At the same time, to avoid skin irritation, it is not too coarse.



The textured viscoelastic grip serves to reduce contact forces.

Evaluation of handle design

To evaluate the different aspects of the handle of a hand tool, the steps listed below should be followed:

1. Examine the various aspects of handle design according to Table 3.1, page 71. Male and female operators may be considered separately.
2. Award scores to the different aspects of the tool using Table 3.1. An aspect can be awarded: preferred – 0; acceptable – 1; permitted – 3; and to be avoided – 5.
3. Taking the application of the tool into consideration, choose the corresponding values of the weighting factors $a_1 - a_{10}$ according to the second column of Table 3.1.
4. Multiply the score by the weighting factor and add all the scores together. The lower the score, the better the tool.

Evaluation of hand-held power tools - handle design					
Variables	Weighting factors (a)	Optimal (0)	Acceptable (1)	Permitted (3)	Not suitable (5)
Circumference with the trigger activated	a1=1, no appreciable force application; a1=2, with appreciable force application	Male 110-130 mm; Female 100-120	Male 105-110 mm or 130-140 mm; Female 95-100 mm or 120-130 mm	Male 100-105 mm or 140-155 mm; Female 90-95 or 130-140 mm	Male <100 or >155 mm; Female < 90 or >140 mm
Max. circumference with trigger open - lever trigger	a2=1	Male <170 mm; Female <160 mm	Male <180 mm; Female <170 mm	Male <190 mm; Female <180 mm	Male >190 mm; Female > 180 mm
Max. circumference with trigger open - finger trigger	a3=1	Male <150 mm; Female <130 mm	Male <160 mm; Female <140 mm	Male <170 mm; Female <150 mm	Male >170 mm; Female >150 mm
Length* for pistol grip and angle tools	a4=1, no appreciable force application; a4=2, with appreciable force application	Male 100-120 mm* Female 85-100 mm*	Male 90-100 mm* or 120-135 mm* Female 80-85 mm* or 100-120 mm*	Male 80-90 mm* or 135-150 mm* Female 75-80 mm* or 120-140 mm*	Male <80 or >150 mm*; Female <75 or >150 mm*
Length* for straight tools	a5=1	Male >100mm* Female >85 mm*	Male 90-100 mm* Female 80-85 mm*	Male 80-90 mm* Female 75-80 mm*	Male <80 mm* Female <75 mm*
End marking	a6=0.5	Smooth end markings, with even surface	No end markings	Descending or pronounced end markings	End markings with sharp edges or rough pattern which interferes with force applications
Adjustability	a7=0.5	Adjustable to fit individual operators	Not adjustable		
Support surface	a8=0.5	Support surface such as flange provided to assist force application and for safety reasons	Support surface not provided, but no obvious risk of injury or interference with work performance		Support surface not provided, risk of injury
Viscoelastic coating	a9=0.5	Ideal material, used to provide comfortable grip	No coating	Poor grip comfort	
Friction and ventilation	a10=0.5	Surface texture specially designed for good friction and ventilation	Painted surface	Polished surface	

* All length limits should be increased by 10 mm when gloves are used.

Table 3.1 Guide for evaluation of handle design.

Bibliography

Chaffin, D.B. and Andersson, G.B.J.: 1991, Occupational biomechanics, John Wiley & Sons, Inc., New York.

Olle Bobjer et al.: Friction between hand and handle, Effects of oil and lard on textured and untextured surfaces, Applied Ergonomics, 1993, Vol. 24, 190-202.

Eastman Kodak Company: 1983, Ergonomic design for people at work, Van Nostrand Reinhold Company, New York.

Hall, C: 1995, Hand function with special regard to work with tools, Arbete och Hälsa (Ph.D. thesis) 1995:4

Pheasant, S.: 1986, Bodyspace, Taylor & Francis, London.

Putz-Anderson, V.: 1988, Cumulative trauma disorders, Taylor & Francis, London.

Sandvik - Ergonomiska verktyg på vetenskaplig grund.



Palm grip sander.

External load

When using a hand-held power tool, the operator's hand, arm and shoulder system are subjected to the forces generated by the tool in use and the weight of the tool. Excessive load of this type may cause fatigue or, at worst, result in damage to the operator's musculo-skeletal system. To minimize this risk, the level, frequency and duration of the load must be taken into consideration when designing the workstation and selecting the tools.

Forces from hand-held power tools

Typical external load includes feed force and reaction torque. Feed force is the force needed to push a tool towards a working object – for instance, the force needed to push a drill bit into a workpiece when drilling.

Feed force usually acts along the longitudinal axis of a pistol- or straight-type tool,

and perpendicular to the longitudinal axis of an angular type tool. Many tools employ the rotation principle. During operation, the tool generates a rotational torque which overcomes resistance from the workpiece. Meanwhile, the rotational movements may generate a dynamic torque. These two torques together must be balanced by a reaction torque applied by the operator's hand in the opposite direction.

The effect of the forces on the operator's body depends on the type of tool, the handle design, and the task performed. The same feed force and reaction torque may influence the operator's arm, hand and shoulder differently, and place different load requirements on the muscles used.

For instance, when used on a vertical workpiece, the feed force from a tool with a pistol handle is limited by the operator's muscular capacity to push the tool forward. The same feed force may subject the wrist to greater bending torque when operating the tool at shoulder level than operation at



Fig. 3.3 The same feed force applied by the operator causes a different load on the wrist depending on posture.

elbow level (Fig. 3.3). The same feed force in a tool with a straight handle used on a horizontal workpiece is limited by the operator's muscular capacity to push the tool down (ulnar push force). The strength of the person's grip can also be a limiting factor, as there is a tendency for the hand to slip on the handle.

Similarly, the reaction torque in a pistol handle tool used on a vertical workpiece applies an axial rotation torque to the operator's forearm. Therefore the forearm's muscular capacity to rotate, supination or

pronation, will determine the maximal allowable installed torque of a pistol-type tool. An intolerable torque in a pistol handle tool may well be tolerable in an angular-type tool, due to the advantage of pulling muscle strength as well as the extra leverage provided by the angular tool (Fig. 3.4).

In summary, feed force and reaction torque during hand tool operations demand different actions from the hand-arm system, depending on the tool design and the tasks being performed.



Fig. 3.4 When using pistol grip tools, torque applied by the operator is limited by the operator's supination torque capacity. For higher torque an angle nutrunner is a better alternative utilizing the pulling back force to balance the installed torque.

Human force generating capacity

The above actions are limited by the force generating capacities of individual operators. A common measure of their capacity is muscular strength, i.e., the maximal force that a group of muscles can develop under prescribed conditions.

Since the muscles must be activated voluntarily, some authorities refer to muscular strength as producing Maximum Voluntary Contraction (MVC) levels. In this regard, the measured strength values, even with well-motivated subjects are probably below the physiological tolerance of the muscle-tendon-bone system, thus providing a safety factor against over-exertion. The extent of this “safety factor” is not really known, but it could be as great as 30%. However, epidemiological studies have shown that when a job requires more exertion than a person would give voluntarily, there is a much greater risk of injury.

Normal muscle strength values are usually obtained from volunteers belonging to specified groups (e.g., male, female, working population, domestic population, etc.) under prescribed conditions. It should be noted that there are substantial individual variations in muscular capacity

data – the strongest is 6-8 times stronger than the weakest.

Of the many factors which may influence muscular strength, gender accounts for the largest difference in average strength values. The strength of the average woman is approximately two-thirds that of the average man. This average covers the capacities of many different muscles. The strength of the different muscles in the hand-arm-shoulder system of a woman can be anywhere between 35% and 80% of that of a man.

Age is another factor which influences muscular strength. In general, a person’s strength appears to be at its peak in the late twenties and early thirties, declining thereafter. In an average population, strength at age 40 appears to be approximately 5% less, and at age 60, 20% less than in the late twenties. Physical differences, such as weight and stature, also influence muscular strength.

However, physical dimensions alone are not a reliable guide to strength. Thus, if a certain amount of strength is required to perform a given task safely, choosing an operator based on size, shape or weight alone will not be enough.

Muscle strength values for different arm operations have been obtained from various population groups. These can serve as guidelines for hand tool designers when they decide the feed force and reaction force of the tools.

Pushing and pulling

Pushing a tool forward is one of the most common operations in hand-held power tool applications. For the majority of the working population the maximal capacity to apply force by pushing forward may be set at 275 N for a male seated operator in optimal working conditions.

During the action of pushing forward, the relatively strong muscles of the arm – the biceps, brachialis and triceps – come into play. Therefore, the operator can generate much greater force than when pushing inwards, outwards, upwards or downwards. Corresponding force capacity limits can be found in Table 3.2.

Wrist torque

Forearm supination refers to rotating the forearm clockwise, as in the action of tightening a screw. Forearm pronation is rotating the

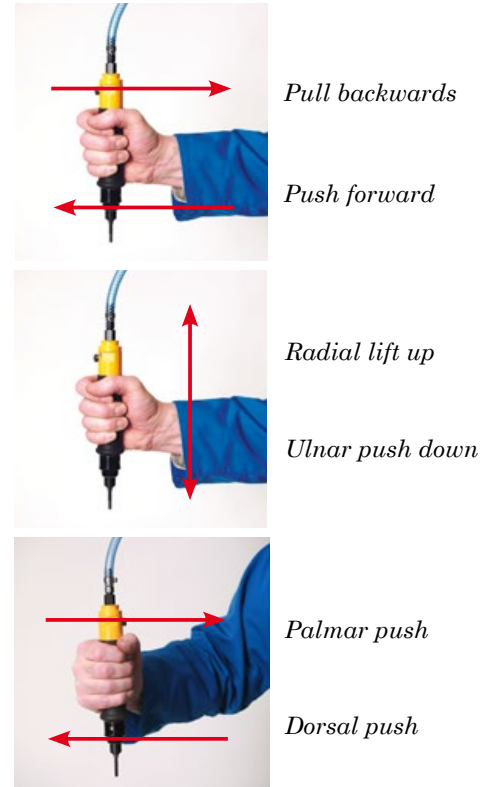

Fig. 3.5 Definitions of the force values given in Table 3.2.

Standing postures	Men	Women
Push forward straight arm	450	340
Pull backward	400	300
Push down straight arm	600	450
Radial lift up	50	30
Ulnar push down	75	50
Dorsal push	55	35
Palmar push	75	50

Sitting postures	Men	Women
Push forward straight arm	275	180
Pull backward	250	170
Radial lift up	50	30
Ulnar push down	75	50
Dorsal push	55	35
Palmar push	75	50

Table 3.2 Maximal Voluntary Contraction (MVC) values with forces in Newton (N). These are practical values based on scientific results and experience.

forearm counterclockwise, as when undoing a screw. On average, men can exert greater muscular strength when performing this action.

The average maximal forearm supination in a male population is a torque capacity of 15 Nm. Maximal forearm pronation is roughly the same, 15 Nm. Using the ratio 2/3 to estimate female muscular strength limits, corresponding maximal torque capacities for female operators would be approximately 10 Nm for both forearm supination and pronation.

Radial and ulnar flexion refer to the rotation of the wrist. Radial flexion is when lifting, for example, the outer end of an angle nutrunner, and ulnar flexion is pushing it down. The maximal radial or ulnar flexion torque for men is 15 Nm. Corresponding values for women can be estimated at two-thirds of those for men.

Dorsal and palmar flexion refer to the torque needed to handle a straight screwdriver. Dorsal flexion is when tightening is performed by a right-handed person and palmar flexion is when loosening a screw. The maximal dorsal flexion torque for men is approximately 10 Nm and palmar flexion torque is 15 Nm.

Gripping

The maximal gripping force that an operator can apply depends on the dimension of

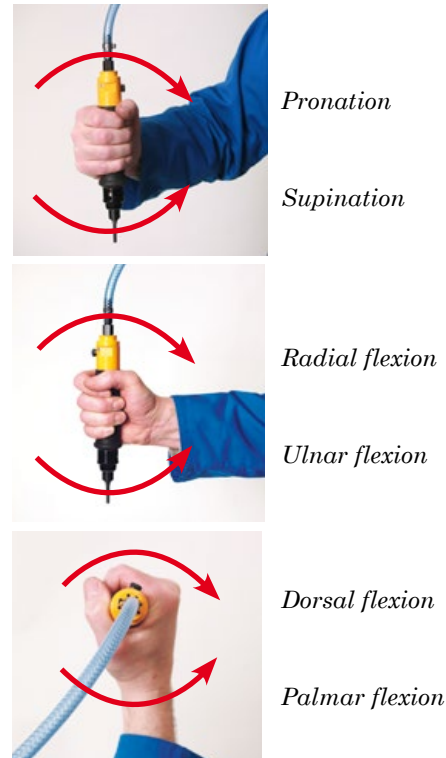

Fig. 3.6 Definitions of the wrist torque values given in Table 3.3.

Sitting and standing	Men	Women
Supination	15	10
Pronation	15	10
Radial flexion	15	10
Ulnar flexion	15	10
Dorsal flexion	10	7
Palmar flexion	15	10

Table 3.3 Maximal Voluntary Contraction values for wrist torque in Newtonmeters (Nm). These are practical values based on scientific results and experience.

the object, the shape of the object's cross-section and the type of grip. For power gripping an object with a round cross-section and an optimal diameter (about 38 mm for males and 34 mm for females), the maximal gripping force capacity is, on average, 500 N for men and 350 N for women, respectively.

Considering the tendency of the hand to slip on the handle of a tool, these force limits, combined with the size and surface condition of the handle, can be used to determine the maximal thrust force and rotational torque for a cylindrical tool, e.g., a straight screwdriver.

The maximal thrust force that can be generated using the maximal gripping force can be calculated using the following formula:

$$\text{Maximal thrust force} = \text{Maximal gripping force} \cdot \mu$$

Where μ is the coefficient of friction which ranges from 0.10 to 2.22, depending on the texture of the handle's surface, material properties, environmental conditions such as temperature and lubrication. Depending on the coefficient of friction, the maximal thrust force varies from 50 to 1,100 N for men (maximal gripping force 500 N), and 35 to 750 N for women (maximal gripping force 350 N). These figures can be compared with the maximal ulnar push-

down force force (75 N for men and 50 N for women in sitting work) given in Table 3.2. In most handle designs (handle friction), the forces from the hand-arm system are the limiting factors, and not the grip itself.

In the same way, variation in the maximal rotational torque can be calculated using the variation in the friction coefficient.

Triggering

Several types of trigger are available. The most common are the finger trigger, the lever trigger and the thumb trigger. To evaluate the finger trigger it is necessary to know which finger or fingers are used. If one finger is used, use the MVC capacity for that finger. If several fingers are used, for example on a level trigger, add the MVC for the respective fingers together.

When a lever trigger is operated with the palm of the hand, such as on a standard grinding machine, the feed force and the trigger force are applied in the same direction. However, trigger forces exceeding 30% of the average feed force are not recommended. The same general rule applies to thumb triggers

Sitting postures	Men	Women
Grip force	500	350

Table 3.4 Maximal Voluntary Contraction values for grip force.

Fingers	Maximal capacity of individual fingers		MVC for trigger operation
	Male	Female	
Thumb	100	65	= sum of the maximal capacity of the fingers involved
Index	80	50	
Middle	130	85	
Ring	100	65	
Little	70	45	

Table 3.5 MVC for trigger operation in Newton (N). Practical values based on scientific results and experience.

on, for example, chipping hammers, where force is also applied in the same direction as the feed force.

Allowable load limits

Load level consideration

It should be noted that the above strength limit values are average maximum voluntary contraction (MVC) of normal operators. There are considerable physical variations between operators and ideally the MVC for the operator in question should be used. In industrial work there is a risk of musculoskeletal disorders when the load is higher than 30% MVC of the operator and at a load level of 40% MVC, blood circulation can be affected. For occasional tasks, the load level should be limited to 50% of the maximal force capacity of the operator and must not exceed 70% MVC. For highly repetitive work the load should be as low as 10-15% of MVC.

Reduced MVC

To determine the maximum allowable force limit for a specific action, one should refer to the maximal human force generating capacity data listed in Table 3.2 and 3.3. This capacity should then be reduced due to the speed of movement of the tool, frequency of operation and the total use (duration) of the tool per day (safety factors a_1 , a_2 , a_3).

Safety factor a_1

Speed of movement when performing the operation

The maximal force generating capacity of muscles decreases when they contract rapidly, due to the viscous friction caused by the fluid viscosity of the muscle. The maximum force allowed should therefore be reduced in operations involving obvious fast movements. A safety factor of 0.8 may be used in such cases. In most cases assembly operations should be regarded as involving fast movements. Material removal operations on the other hand normally do not involve fast movements.

Type of operation	Safety factor a_1
No fast movements	1
Fast movements	0.8

Table 3.6 Safety factor a_1 to reduce MVC due to fast movements in the operation.

Safety factor a_2

Frequency of the operation

The capacity of a muscle group to generate force is related to the degree of muscle fatigue. The more fatigued the muscle, the lower the maximum force generating capacity. The fatigue effect depends on the frequency and duration of each operation. When considering the effect of operation frequency on the maximum allowable force, a safety factor may be selected according to Table 3.7.

Operation duration(s):	Frequency of operation (times/min.):	
	<6	>6
	Safety factor a_2	
<3 seconds	1.0	0.6
3-10 seconds	0.7	0.3
>10 seconds	0.6	-

Table 3.7 Safety factor a_2 to reduce MVC due to frequency of operation.

If frequency is not known, the total duration of use, Table 3.10, can be of help. The total duration of use for a screwdriver, for example, is two hours per day.

Let's assume that each tightening cycle lasts two seconds. This gives 3,600 tightening cycles per day, 450 per hour, on average 7.5 tightenings per minute.

In this case $a_2 = 0.6$.

Safety factor a_3

The total duration of the operation

The maximum force generating capacity is reduced as the total duration of the work task increases and muscles become fatigued.

Total duration per day (a_3) should also take into consideration other tasks performed during the day where the same muscle groups are used. For instance, if there is time for other tasks, and they involve using other hand-held tools which also need to be evaluated, the evaluation tends to become rather complicated.

If the total duration of operation is less than one hour in a working day, the influence of duration on muscle fatigue can be ignored. However, if the total duration of the operation is longer than one hour, a safety factor must be taken into consideration when calculating the maximum allowable force limit. When the total duration of operation is 1 to 2 hours, a safety factor of 0.8 may be included and when the duration is longer than 2 hours in one working day, the safety factor should be 0.5.

Total duration per day	Safety factor a_3
Less than 1 hour	1
Between 1 and 2 hours	0.8
More than 2 hours	0.5

Table 3.8 Safety factor a_3 to reduce MVC due to total duration per day of operation.

Real external load

After the MVC has been reduced, the remaining permissible force or torque should be compared with the real external load. If this load is not known, it can be measured – for example, trigger forces for pneumatic tools connected to an air line.

Machine group	Average force (N)	Spread \pm (N)
Grinders	60	40
Drills	150	100
Chipping hammers	120	60
Riveting hammers	100	50
Nutrunners	50	20
Screwdrivers	50	20

Table 3.9 Typical feed forces for different machine groups.

Push and feed forces are not easy to measure in a process. Table 3.9 provides estimated feed/push forces for different machine groups.

It is self-evident that the forces involved increase in proportion to the power of the machine used. The spread value provided confirms this fact.

Evaluation of external load

The purpose of the evaluation is to compare calculated permissible load on the operator with the real load.

From the tables in the preceding chapters the MVC for different load types can be found. This MVC is then reduced according to the recommendations above.

Finally the R-value for each load is calculated by dividing the real external load by the reduced MVC.

The score for that external load can then be obtained from the figure below. This procedure should be followed for each external load present.

The total score is the sum of the scores for the individual loads.

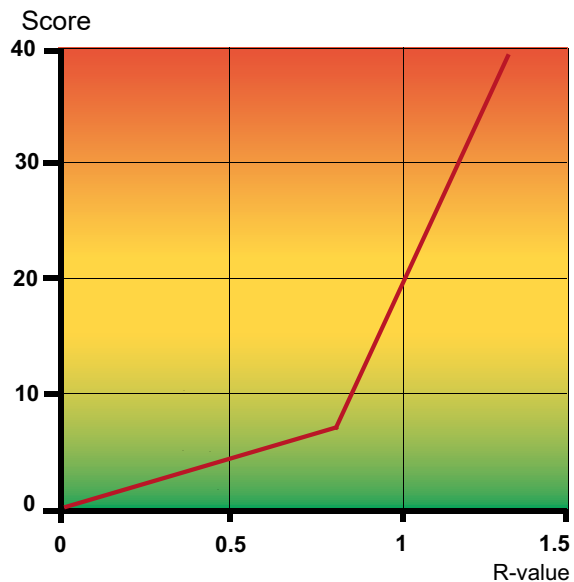

Fig. 3.7 The score for external load can be obtained from this figure, using the R-value for each type of external load present.

Comments for different tool types

In this section the different types of tools are discussed. A tool can be used in an infinite number of different ways and the load on the operator is unique for each situation. The discussion below can therefore only be used as a rough guide, giving an indication of what to think about when the load on the operator is estimated.

Normally, more powerful tools require more force. This can be taken into account choosing a force within the spread given in the table.

When the trigger time per day for an operation is not known, Table 3.10 can be used as a guide.

Machine type	Total duration (hours/day)	Spread \pm (hours)
Grinders	3	1.5
Drills	1	0.5
Chipping hammers	2	1.5
Riveting hammers	1	0.5
Screwdrivers	2	1
Impact wrenches	1	0.5
Impulse nutrunners	2	1
Angle nutrunners	2	1
Stall torque nutrunners	1	0.5

Table 3.10 Typical durations in hours per day for different machine groups.

Grinders

The important external loads when handling a grinder are the feed force and the trigger force. The feed force is typically a combination of a standing push-down or push-forward force and an ulnar-flexion torque.



For tools operated with two hands the torque and forces can be calculated if the torque is estimated to be equal for both hands and the influence of the mass of the tool is disregarded. This will lead to calculated forces that are 0-50% too high. For pneumatic tools the force in the support handle is normally about 70% of the total feed force and for electric tools it is about 80%.

The ulnar-flexion torque can be estimated as the force in the support handle multiplied by the horizontal distance from the center of the support handle to the point on the wheel where the downward force is applied.

For tools operated with one hand the feed force equals the force in the hand and the ulnar-flexion torque is the feed force multiplied by the distance from the center of the hand to the point on the wheel where the force is applied.

Trigger force can be measured. Depending on the type of trigger, the trigger force is distributed over the fingers.

Normal use of grinders does not involve fast movements. Frequency is less than 6 times per minute and duration more than 10 seconds per operation.

Total duration can vary a great deal. Try to find the real total duration for the workplace in question. If that is not possible use the values in Table 3.10.

Drills

The important forces are force and torque from the feed force, the torque from the drill operation and the trigger force.



For pistol grip drills feed force is horizontal or vertical push force. A torque is generated equal to the distance from the main axes of the tool to the center of the hand, multiplied by the feed force used. This torque is an ulnar-flexion torque.

The torque from the drilling operation is a supination torque. The maximal torque can be calculated when the power of the tool is known. Assuming the maximum power is when the tool is loaded down to half the free-running speed, the maximum power torque can be calculated as:

$$\text{Max. power torque} = \frac{\text{Max. power} \cdot 10}{\text{free-running speed}}$$

Pistol grip tools normally have a trigger operated with the index or long finger,

depending on the grip chosen. For straight tools the maximal feed force is the standing or sitting push-down or push-forward force depending on the workstation design. Torque in the wrist to counteract the torque from the drilling acts as a dorsal-flexion torque. In some cases, where the handle has low friction the gripping force can be the limiting force.

For angle drills, when operated with one hand, the feed force results in an ulnar-flexion torque. Torque is calculated as the feed force needed multiplied by the distance from the drill bit to the center of the hand.

Normal use of drills does not involve fast movements. Frequency is less than 6 times per minute and duration more than 10 seconds per operation.

Total duration can vary considerably. Try to find the real total duration for the workplace being analysed. Use the number of holes drilled multiplied by the duration, i.e., the time taken to drill one hole. If that is not possible use the values given in Table 3.10.

Percussive tools

The important forces are the feed force, and the trigger force. Feed force for chipping hammers acts as a standing push down force. For riveting hammers it is a standing push forward force.



The trigger is either operated by the thumb or by the index finger depending on the design of the tool.

Straight chipping hammers normally have triggers operated by more than one finger.

Normal use of chipping hammers does not involve fast movements. Frequency is less than 6 times per minute and duration more than 10 seconds per operation. Riveting hammers are often used with frequencies higher than 6 times per minute and the duration of the operation is less than one second.

Total duration can vary a lot. Try to find the real total duration for the workplace being analysed. If that is not possible, use the values in Table 3.10.

Screwdrivers

The important forces are torque from the tightening, the feed force, and the trigger force.

For straight tools the force from the tightening torque is experienced as a wrist dorsal-flexion torque. It is transferred to the hand as friction between the hand and the tool surface. For surfaces with low friction the grip-force can be the limiting factor. The maximal torque that a given grip-force can transfer can be calculated as the grip-force times the coefficient of friction times the diameter of the handle.



Normally the wrist's ability to handle the torque is the limiting factor.

For certain types of screws, e.g., self-tapping screws, a considerable amount of feed force might be needed. For those cases the grip-force can be the limiting factor for the feed force. Trigger forces are normally low and distributed over several fingers.

For pistol grip screwdrivers tightening torque, weight distribution, feed force and trigger forces should all be taken into account. Tightening torque is experienced as a supination torque in the wrist.

Bad weight distribution might give a radial-flexion torque equal to the weight of the tool times the distance from the center of gravity to the center of the handle. This torque might be a problem while the tool is moved to and from the bolt.

Force and torque from the feed force is assessed as for drills.

Trigger force is normally handled with the index or long finger.

Normal use of screwdrivers involves fast movements. Frequency is more than 6 times per minute and duration is less than 3 seconds per screw.

Total duration can vary considerably. Try to find the real total duration for the workplace being analysed. The number of screws multiplied by the duration, i.e., time

taken to tighten one screw, can be used. If that is not possible, use the values given in Table 3.10.

Impact and impulse nutrunners

The important forces are weight distribution of the tool, trigger forces, the feed force and, for bigger tools, the torque from the motor.

Poor weight distribution might give a radial-flexion torque equal to the weight of the tool times the distance from the center of gravity to the center of the handle.

Trigger force is normally handled with the index or long finger.

In some applications feed force needs to be considered, e.g., applications where small impact tools are used for self-tapping bolts.

The reaction torque acting on the handle is only a small fraction of the installed torque. The torque experienced is only the torque from the vane motor itself. For impulse tools this torque can be approximated as the tool's maximum torque capacity divided by 40 and for impact tools the corresponding figure is the maximal torque capacity divided by 120.

Normal use of impact and impulse nutrunners involves fast movements. Frequency is more than 6 times per minute and



duration is less than 3 seconds per screw. Total duration can vary considerably. Try to find the real total duration for the workplace being analysed. Number of screws times the duration, i.e., time taken to tighten one screw can be used. If that is not possible use the values given in Table 3.10.

Angle nutrunners

The important forces are the reaction torque from the tightening, weight distribution of the tool and trigger forces.

The reaction torque from the tightening is regarded as a shock reaction if the tightening time is shorter than 300 ms. When the tightening time exceeds 300 ms the muscles in the hand-arm system have time to counteract and the torque reaction is assessed as a force acting on the hand-arm system.

In most cases where the tool is used in a two-handed operation the force is handled as a standing pull force in the right arm and a slightly smaller standing push force in the left arm. This can vary considerably, depending on the posture required to reach the bolt to be tightened.

Many problems relating to reaction torque are due to the fact that reaching the bolt requires awkward postures.

In some cases angle nutrunners are



used in one handed operations. The torque reaction is than handled as a combination of a standing pull force and a palmar-flexion torque. The pull force is the installed torque divided by the distance from the angle head to the middle of the handle. The maximal palmar-flexion torque can be estimated as the installed torque divided by the distance from the angle head to the middle of the handle, multiplied by the height of the angle head above the bolt head. This means that when extensions are used in one-handed operations the palmar-flexion torque often becomes high.

Handling an angle nutrunner with one hand exposes the wrist to a radial-flexion torque equal to the weight of the tool multiplied by the distance from the center of gravity to the mid-point of the handle. Poor weight distribution might give high radial-flexion torque. Larger tools need to be suspended in balancers to reduce the radial-flexion torque.

When the tool is positioned on the bolt with only one hand holding the handle, a supination torque, that equals the weight of the tool multiplied by the distance from the center of gravity to the midpoint of the handle, will load the operator.

Normal use of angle nutrunners involves fast movements. Frequency is more than 6 times per minute and duration is

less than 3 seconds per tightening. Total duration can vary considerably. Try to find the real total duration for the workplace being analysed. Number of screws times the duration, i.e., time taken to tighten one screw, can be used. If that is not possible, use the values given in Table 3.10.

Nutrunners designed for use with reaction bars



The only forces acting on the operator are from the handling of the tool, the suspension system and the trigger force.

Some operators try to work at a faster pace than the system is designed for. Due to the fact that the suspension system often is heavy the forces from accelerating the mass of the system can be considerable.

Normal use of nutrunners designed for use with reaction bars involves no fast movements. Frequency is less than 6 times per minute and duration is less than 3 seconds per tightening.

Total duration can vary a lot. Try to find the real total duration for the workplace being analysed. Number of screws times the duration, i.e., time taken to tighten one screw, can be used. If that is not possible use the values given in Table 3.10.

Bibliography

Atlas Copco Tools AB: 1990, Tryckluftdrivna industrimaskiner, Training material from Atlas Copco Tools AB, Stockholm.

Björkstén, M., Jonsson B.: 1977, Endurance limit of force in long-term intermittent static contractions, Scand J Work Environment & Health 3: 23-27.

Byström, S.: 1991, Physiological response and acceptability of isometric intermittent handgrip contractions, Doctoral thesis, National Institute of Occupational Health, Stockholm.

Chaffin, D. B. and Andersson, G. B. J.: 1991, Occupational biomechanics, John Wiley & Sons, Inc., New York.

Dul, J., Douwes, M., Smitt P.: 1994, Ergonomic guidelines for the prevention of discomfort of static postures based on endurance data, Ergonomics 37, 807-815.

Jonsson, B.: 1984, Muscular fatigue and endurance: basic research and ergonomic applications, In: Neural and mechanical control of movement, M. Kumanoto (Ed.), Yamaguchi Shoten, 64-76, Kyoto.

Mathiassen, S. E.: 1993, The influence of exercise/rest schedule on the physiological and psychophysical response to isometric shoulder-neck exercise, Eur J Appl Physiol 67, 528-539.

Mital, A.: 1985, Preliminary guidelines for designing one-handed material handling tasks, J Occup Accidents 4, 33-44.

Pheasant, S.: 1986, Bodyspace, Taylor & Francis, London.

Åstrand, P.O., Rodahl, K.: 1986, Textbook of work physiology, McGraw-Hill, New York.

Hallén, K.: 2004, Maximal momentkapacitet. Technical report from Atlas Copco Tools AB, Stockholm.

EN 1005-3+A1, Safety of machinery – Human physical performance – Part 3: Recommended force limits for machinery operation.

Weight

The weight of a hand-held tool is a typical external load to which the operator is subjected. Depending on the working posture, the weight of the tool applies different torques to the joints of the hand-arm-shoulder system. The risk of a tool causing work-related musculo-skeletal disorders varies according to the amplitude of the torques as well as the duration of the task performed.

In modern industrial situations, many hand-held tools are electrically or pneumatically powered in order to reduce the effort required from the operator.

However, this approach sometimes results in a heavy tool, especially when stiff, heavy hoses are used. It is not uncommon to find hand-held tools weighing more than 5 kg. Even if a tool of this weight is held in an ergonomically optimal position, it will still exert a torque on the shoulder joint

equivalent to about 20% of the person's maximal force generating capacity (20% MVC) for a male operator and 30% for a female operator. The weight-related exposure on operators is therefore a major ergonomic concern.

Tool weight limit

There are no simple recommendations specifying tool weight limits for all situations. As an external load, the weight should be limited according to the working conditions, and the frequency, speed and duration of the operation to be performed. Weight as a load factor should be added to the other vertical forces applied to the operator.

As a general rule, if the weight of the tool has to be borne by the operator during operation, tools heavier than 2.5 kg should be suspended, counter-balanced, or have two handles. For precision operations, tools weighing more than 0.4 kg are not recommended. For tougher jobs, such as drilling concrete, heavier tools may be necessary to help absorb vibrations and supply feed force.

Weight suspension

Tool balancers counter-balance the weight of a tool. In principle there are two types.

The first type (RIL) has a lifting force which increases as the wire is extended. When a tool is suspended using this balancer, its weight is offset by the lifting force. The height can be adjusted by presetting the spring in the balancer. If the tool needs to be suspended at a higher level, the spring in the balancer must be tightened.

The second type of balancer, Colibri, has a built-in wire drum which compensates for the extension of the wire. When a tool is suspended using this balancer it can be positioned anywhere along the length of the extended wire. The spring force in the balancer is preset according to the weight of the tool.

Naturally, tool balancers limit the operating area of the tool. When using a balancer, it is important that the counteracting force is properly adjusted. Otherwise excessive lifting forces from the balancer, may place an unnecessary load on the operator.

In certain work situations such as construction sites, the mobility of a hand tool is very important, i.e., it should be possible to use the tool in different locations and at various angles. A weight balancer is therefore not practical and, in such situations, the weight of the tool should always be limited.



A balancer compensates for the weight of the tool.

The center of gravity of the tool

Another aspect of weight is the center of gravity of the tool. In some situations, if the center of gravity of the tool is not close to the operator's wrist joint, torque may be exerted on the wrist. If applied for a prolonged period, this may cause fatigue to the forearm muscles and injury to the wrist.

To limit this torque, the tool's center of gravity should never be far from the wrist joint. For the same reason and for maximum

stability of grip, the center of gravity of the tool should be as close to the center of the gripping hand as possible. A T-type handle is a good choice in this respect, provided that the feed force required is low.

Influence of tool usage

There are static and dynamic aspects to weight. Other parameters not discussed here are, for example, performance and productivity. Comparing a heavy, powerful machine with a lighter, less powerful machine is pointless. For certain tasks, a well-designed air line maintaining a high inlet pressure to the machine makes it possible to select the lightest machine for the job. The static aspect is relatively easy to understand. The significant factor is the bending or rotational torque of the wrist, which can be influenced by the choice of handle.

If the machine is moved very quickly during repetitive assembly work the entire hand-arm system will be affected. In this case it is not possible to make any general statements. Every workstation is unique and must be studied accordingly.

When is machine weight important?

The weight of the machine places a load on the operator as he moves it towards the workpiece. During the process, however, other forces often dominate. The time it



Fig. 3.8 Positioning the handle near the center of gravity reduces the wrist torque.

takes to move the machine to the workpiece depends on the layout of the workstation. During transport the machine is often held in a different grip from the grip used to perform the process. The latter grip usually reduces the load on the hand-arm system. When grinding on a horizontal surface the weight acts as part of the feed force.

Evaluation of weight

Machine weight is experienced as load in different ways depending on the operator's posture, the design of the handle and the type of process. We suggest using the machine weight without a tool inserted as the parameter when evaluating the impact of weight on the operator. It is very rare that a power tool manufacturer adds extra weight to his tools. The final weight of a design reflects how well the designer has understood the technical and ergonomic demands.

Bibliography

Chaffin, D. B. and Andersson, G. B. J.: 1991, *Occupational biomechanics*, John Wiley & Sons, Inc., New York.

Eastman Kodak Company: 1983, *Ergonomic design for people at work*, Van Nostrand Reinhold Company, New York.

Kadefors, R., Areskoug, A., Dahlman, S., Kilbom, E., Sperling, L., Wikström, L., Öster, J.: 1993, *An approach to ergonomic evaluation of hand tools*, *Applied Ergonomics*, 24, 203-211.

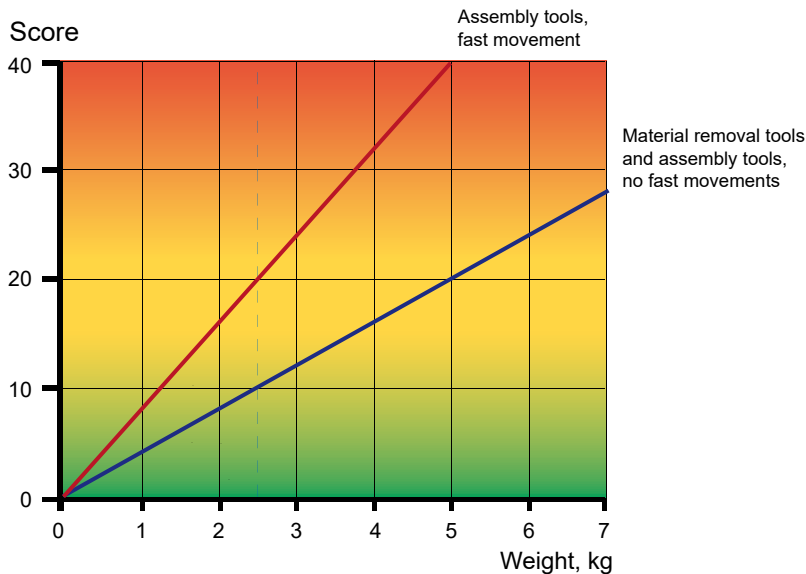

Fig. 3.9 Evaluation diagram for weight of assembly and material removal tools. It is recommended that heavier tools, with weights exceeding 2.5 kg, should be suspended from balancers (see vertical dotted line). This applies in particular to assembly tools used for repetitive work.

Temperature

Hand-held power tools often contain heat or cold sources which affect the temperature of their surfaces. Contact with these surfaces may cause the tool operator discomfort, pain and even injury. Thus, it is the responsibility of the tool designer to keep the temperature of the surface of the hand tool within limits that will not affect the health of the operator.

A relatively large amount of research has been done on the physiological responses of the human being exposed to hot surfaces. Standards and guidelines concerning acceptable limits for hot surfaces (e.g. the standard ISO 13732-1) is available based on these studies.

For exposure to cold surfaces ISO 13732-3 provides guidelines for designers constructing a hand-held power tool that gets cold during use.

Factors influencing temperature limits

The following factors may influence tolerable temperature limits:

- Surface temperature, i.e., the temperature of a handle surface measured on the Celsius scale;
- Contact period, i.e., the period of time during which contact with the surface takes place;
- Thermal inertia, i.e., the combined effect of the density, thermal conductivity and specific thermal capacity of the material used in the construction of the tool. (A list of thermal inertia for some common materials is given in Table 3.11.)
- Material properties of the surface; i.e., the chemical/physical composition of the material and the characteristics (rough, smooth) and shape of the surface.

Material	Thermal conductivity W/(m•K)
Skin	0.55
Aluminum	203
Steel	45.5
Nitrile	0.15
Abs resins	0.18
Nylons	0.21
Acetal	0.23

Table 3.11 Thermal properties of selected materials.

Temperature limits for hot surfaces

The burn threshold

Surface temperature data for burn thresholds according to the 13732-1, are presented in Fig. 3.10, giving the burn threshold curve for contact with a hot surface of smooth, uncoated metal for 1 to 10 seconds. Generally, the temperature of a smooth uncoated metal surface should not be higher than 54° Celsius for a contact period of 10 seconds.

Plastics and rubber can significantly raise the burn threshold due to the differences in their thermal inertia properties. Table 3.12 shows burn threshold data for longer contact periods (>1 min.).

For frequent intermittent operation (e.g., contact period >10 min.) and continuous operation (8 hours contact), the per-

missible temperatures based on the burn thresholds are 48° and 43° Celsius, irrespective of the characteristics of the material.

It may be noted that the value of 51°C for a contact period of 1 minute also applies to other materials with high thermal conductivity which are not indicated in the table.

The value of 43°C for all materials for a contact period of 8 hours and longer only applies if a minor part of the body (less than 10% of the skin surface of the body) comes into contact with the hot surface.

Material	Burn threshold for contact periods of		
	1 min.	10 min.	8h and longer
	°C	°C	°C
Uncoated metal	51	48	43
Coated metal	51	48	43
Ceramics, glass and stone materials	56	48	43
Plastics	60	48	43
Wood	60	48	43

Table 3.12 Burn thresholds for different contact periods.

The pain threshold

Acceptable pain threshold temperatures are much lower than the burn threshold temperatures shown above.

For example, pain threshold temperatures are about 75% of the burn threshold for plastics and wood.

To ensure physical comfort during prolonged operation of hand-held power tools, design criteria for acceptable surface temperature should be set at the pain threshold level.

Temperature limits for cold surfaces

Contact with cold surfaces may cause a sensation of cold or pain, and can ultimately result in injury in the form of frostbite. Heat is transmitted from the fingers to the cold surface at a speed governed by the surface temperature, the thermal inertia of the material, the mass of the object, the material properties of the surface, the contact pressure and the moisture content of the skin.

For cold surfaces a subjective sensation of pain at the contacting skin will be experi-

enced at a contact temperature of 15°C. At 7°C sensory receptors of contacting skin will be blocked and numbness will occur. At contact temperatures below 0°C the contacting skin tissue will freeze, causing frostbite. This can be avoided by limiting the surface temperature of the tool, reducing the duration of exposure, reconsidering the materials used and/or surface texture of the handles, or by wearing protective gloves.

Skin temperature drops faster among male operators than females. At very low temperatures, the feeling of considerable pain can take longer to emerge than the time taken for the temperature to drop to 0°C. Therefore it would not be safe to base the design criteria for cold surfaces on the operator's subjective pain feelings.

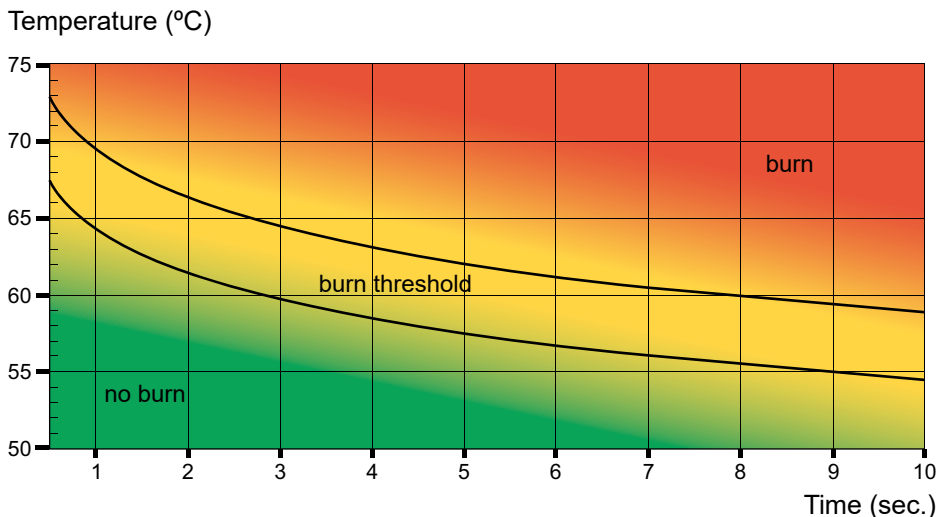

Fig. 3.10 Burn threshold curve for skin in contact with a hot, smooth, uncoated metal surface (from ISO 13732-1, 2008).

From the point of view of operator comfort, the surface temperature of metal tool handles should not be lower than 15°C if continuous operation is anticipated. Lower temperatures call for handle insulating materials or protective gloves. The use of insulating materials, such as plastic and wood, can greatly reduce the speed of cooling of the skin when it comes into contact with cold surfaces.

Evaluation of temperature

For evaluation the lowest permissible temperature is set to 15°C. For the highest temperature, the burn threshold for a contact time of 10 minutes (48°C) is used.

Between these two limits a function has been assumed passing the weighting factor 20 at burn threshold.

Material removal tools

The temperature to be evaluated for these tools is the lowest or highest stabilized handle temperature measured at the handle surface when the machine is running at 50% of its maximum capacity in a brake at the laboratory. The temperature should be measured without holding the handle.

The properties of the handle surface have a strong influence on the temperature and the operator's perception of the temperature.

A meaningful comparison between machines can only be made if the handle surfaces are similar. The decision to place a 50% load on the machine may be questioned.

For example, the temperature of a grinder driven by a vane motor will increase when the machine is running free, due to friction between the vanes and the cylinder wall. Likewise, its temperature will fall when running under load, due to expanding compressed air.

In a real work situation, there are large fluctuations in the power output and consequently in the temperature.

Percussive tools are tested in an energy absorber. For example, a steel ball absorber is used for vibration measurements. The tool is tested in a sequence of starts and stops based on calculations made from the known or assumed average using time of the tool per day.

Assembly tools

An assembly tool is often only used for a few seconds during each tightening sequence and temperature is rarely a problem unless the tool is used in a highly repetitive work situation. The machines are tested with maximum torque setting on a soft test joint in a sequence corresponding to the known or assumed average using time per day.

Bibliography

ISO 13732-1, Ergonomics of the thermal environment – Methods for the assessment of human responses to contact with surfaces – Part 1: Hot surfaces.

ISO 13732-3, Ergonomics of the thermal environment – Methods for the assessment of human responses to contact with surfaces – Part 3: Cold surfaces.

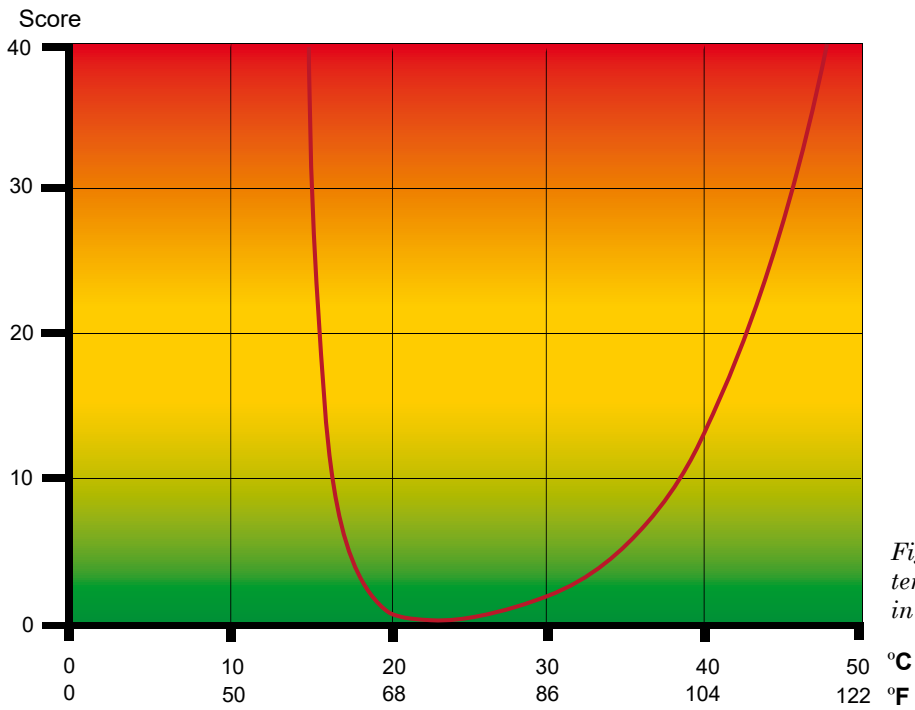

Fig. 3.11 The score for temperature can be found in this figure.

Shock reaction

A shock reaction in a tool is an external load placed on the operator for an extremely short period of time. Tools generating this type of load during use are typically angle nutrunners and screwdrivers. Drills can also generate a shock at the moment when the bit penetrates the workpiece. The unprepared operator can lose his grip on the tool, his fingers may be crushed, or he may receive a blow from the tool.

What is a shock?

A shock and its reaction happen during a short period of time. Events happening during less than 300 ms can be defined as shocks. During this short period an operator is unable to influence the course of events. A tightening cycle lasting longer than 300 ms also subjects the operator to a shock reaction, but that load should be handled according to the methods



Rapid motions of the hand-arm system are perceived as shocks.

outlined in the section on external loads. The hand-arm system can be considered as a passive mass spring system – in particular a mass. The shorter the shock, the smaller the reaction or response in the machine and hand-arm system. If the duration of the shock is gradually increased, the reaction will also increase. Depending on

the dynamic properties of the machine and the hand-arm system, the response will actually be amplified for a certain duration or shock impulse. This is a shock and response situation that we should try to avoid.

How can we influence the duration of the shock?

If we take an angle nutrunner as an example, the length of the shock depends on the joint hardness, the speed of the machine, the power of the motor and the method used to shut off the machine when the tightening cycle is complete.

The joint

A joint can be hard, soft, or anything in between. Joints reaching their final torque after a tightening angle of less than 60° are considered to be hard, and joints reaching their final torque after 700° are soft. A very hard joint is, for example, a thin plate fixed to another component with a bolt. The elongation of the bolt is very short. A typical soft joint is a hose clamp.

As mentioned above, the shorter the shock, as in a hard joint, the smaller the shock reaction. But why do we still use so many medium-soft joints? The answer is that the joint designer wants to have a reliable joint which retains its clamping force after many load changes – the softer the better from this point of view.

Machine speed

The speed of the outlet spindle depends on the torque and speed of the motor. The joint may be sensitive to high speed for temperature reasons. Another parameter which limits the speed is the possibility of over-shoot when final torque is reached. This is a quality issue and it is limited by the speed of the clutch or the capability of the system to control the tightening in the case of an electric tool.

Motor power

The power of the motor also influences the tightening characteristics of the tool. A powerful motor will maintain the speed at the end of the tightening sequence, keeping total tightening time to a minimum. However, if you increase the power of the motor, the tool gets heavier.

Shut-off method

The faster the shut-off, the shorter the duration of the shock.

Summary

All these factors influence the duration of the shock and its reaction on the machine. If a tightening sequence is analysed taking torque as a function of time, we find that as the area under the curve becomes smaller, the impulse is smaller and the torque reaction is reduced.

Shocks into a mechanical system

The tool and the hand-arm system can be considered as a mechanical system. The theory of vibration and shocks tells us that the response from a mechanical system exposed to a shock is a function of the duration of the impulse and the natural frequency of the tool/hand-arm system. The latter depends on the posture of the hand and is therefore closely related to the design of the workstation.

The response

The response can be defined as the amplitude of the motion of the tool handle due to the shock. An operator's subjective perception of the shock reaction can be related to the amplitude of the motion of the tool handle. The displacement of the handle during tightening could be a measure of the probable subjective response from the operator using the machine. The displacement is, however, not easy to measure during actual operation.

A simplified method of quantifying shock reaction, is based on the assumption that shock reaction is directly proportional to tightening torque. The tightening torque is measured with an in-line transducer and the impulse, accounting for the torque reaction, is calculated

by integrating the torque signal versus time.

This type of test set-up however, ignores the dynamic properties of both the tool and the operator.

Machine design

The mechanical development of angle nutrunners has followed two separate paths – pneumatic tools and electric tools.

In pneumatic tools, the design concept has been to minimize the impulse. A key element here is the clutch. Pneumatic angle nutrunners are provided with an extremely fast clutch. When the tool reaches its preset final torque, the clutch disengages the motor from the gear train in 3.5 ms. This fast action improves the accuracy of the tool and the part of the impulse resulting from the disengagement action is very small.

In practice, this means that when the tools are used on hard joints the operator can hold the tool handle between his thumb and index finger and not experience any shock because it will be absorbed by the inertia of the tool.

For softer joints it takes longer to build up the torque, which increases the impulse tending to rotate the tool. To prevent this rotation the operator must apply force to the handle and will perceive this as a shock reaction.



High motor power and fast clutches are important to reduce the shock reaction from angle nutrunners.

The faster the clutch, the softer the joints which can be tightened without excessive shock reaction. For softer joints the shock reaction can be unpleasant. For very soft joints the tightening time could exceed 300 ms. In this case the operator has time to adjust the force he applies to the handle and does not experience any shock, but never the less a reaction force.

The development of electrically driven tools has taken another path – they can be controlled precisely. Changing the speed of

the motor changes the way the operation is perceived by the operator. In fact, different degrees of joint stiffness can result in the same subjective load perception and the operator can select his own optimum ramp function.

In this way the control system can be pre-programmed for different operators. By entering a code at the start of a shift the machine could be automatically adjusted to suit the operator.

Evaluation of shock reaction

There are no standards for the evaluation of shock reaction. Current knowledge cannot tell us how many shocks an operator can be exposed to before they pose a risk.

As mentioned earlier, the shock reaction depends on the impulse entering the machine during the tightening sequence. Since every tool has a torque range, the shock reaction will vary with the torque setting, for the same joint characteristics. The subjective perception of the torque reaction will also vary according

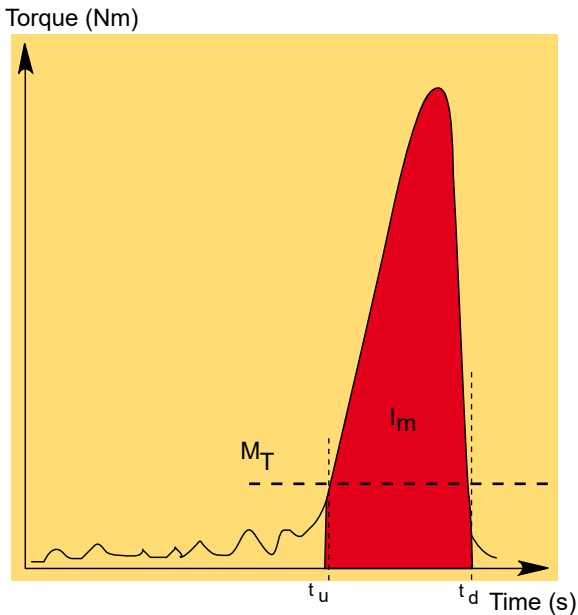

Fig. 3.12 A typical tightening sequence. The area under the curve represents the impulse.

to the work posture. The evaluation procedures must be very simple to be practical. We suggest that the scaling factor is directly proportional to the impulse for the hard joint.

In most cases, a soft joint gives a tightening time in excess of 300 ms and, according to our definition, this is not a shock.

The other reason for selecting the hard joint is that requests for information about impulses from tools working on this joint are received from time to time, particularly from the automotive industry. Many manufacturers and users have access to this joint and can perform measurements. In other words, there are data available.

At the beginning of this chapter it was mentioned that the operator's perception of the shock will be worse when the joint gets softer, and for medium-soft joints his or her perception will be more positive again. Using the hard joint we will be unable to find the worst joint for each torque setting.

However, when comparing different tools at different joints, the one with the lowest impulse could be beneficial.

Three functions are used to evaluate the shock reaction, one for straight tools, one for pistol grips, and one for angle nutrunners.

The reading from the inline transducer is the installed torque during tightening.

The theoretical force at the operator's hand, is calculated by dividing the tightening torque by the diameter of the straight tool. Or, for a pistol grip tool and an angle nutrunner, the torque data are divided by the effective length of the tool measured from the center of the grip handle to the spindle center. This approach however, does not account for the dynamic properties of the tool and the operator.

Force as a function of time is integrated and the impulse (with unit Ns) is compared with the evaluation curve to get the score.

Bibliography

ISO 5393 Rotary tools for threaded fasteners – Performance test method.

Bo Lindqvist: 1993, Torque reaction in angled nutrunners, Applied Ergonomics, 24 (3) 174-180.

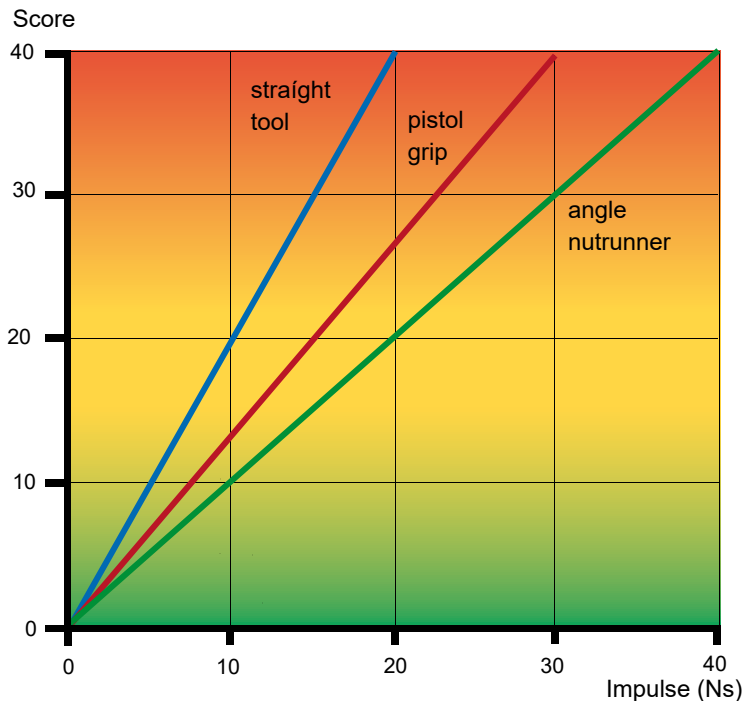

Fig. 3.13 Score for shock reaction for straight, pistol grip and angle nutrunners.

Vibration

All machines vibrate to some extent. Depending on the design, the vibration can cause malfunction, fatigue and breakage of the tool. When operators are exposed, vibration can also cause health problems. In power tools the magnitude of vibration is determined by oscillating forces acting on the machine mass, the excitation of the natural frequencies of machine parts, and vibration from the process itself.

What is vibration?

Vibration is the oscillating motion of an object caused by forces acting on that object, which may be a power tool. Although this back and forth motion, or displacement, can be oriented along one axis, in most cases it has a more complex pattern. To describe the motion you often need three axes and sometimes rotational axes as well, allowing

description of movement in a number of different directions.

If the frequency of the oscillating force coincides with the natural frequency of a component in the tool design, the displacement will be amplified. Machine parts such as handles, for example, can be considered as a mass spring system with their own natural frequencies.

How do we measure vibration?

Vibration can be described in many different ways. The most common method is to use acceleration as the parameter. By integrating the acceleration signal once, the motion is described as velocity. Integrating the velocity gives a description of the displacement.

Acceleration is a rather abstract parameter to be used to describe a motion. There are, however, a number of reasons why it has become the most widely used method.

The most common transducer is a piezo-electric accelerometer, which has a mass pre-loaded by a spring against a

piezo-electric crystal. When the accelerometer is subjected to acceleration, the mass acts on the crystal with a force proportional to the acceleration. The force exerted on the crystal will cause the crystal to send out a charge proportional to the acceleration. The signal can be fed into a computer for evaluation via a charge amplifier.

When measuring vibration in a hand-held power tool with a complex motion, the location of the transducer obviously has a

significant influence on the result. Some literature, in particular that dealing with exposure measurements, suggests that the transducer should be located where the operator places his hands.

If we take a grinding machine as an example, there are many points along the handle where the transducer can be placed. Each will give different readings. For some machines the lowest and highest reading may differ by a factor of five – sometimes

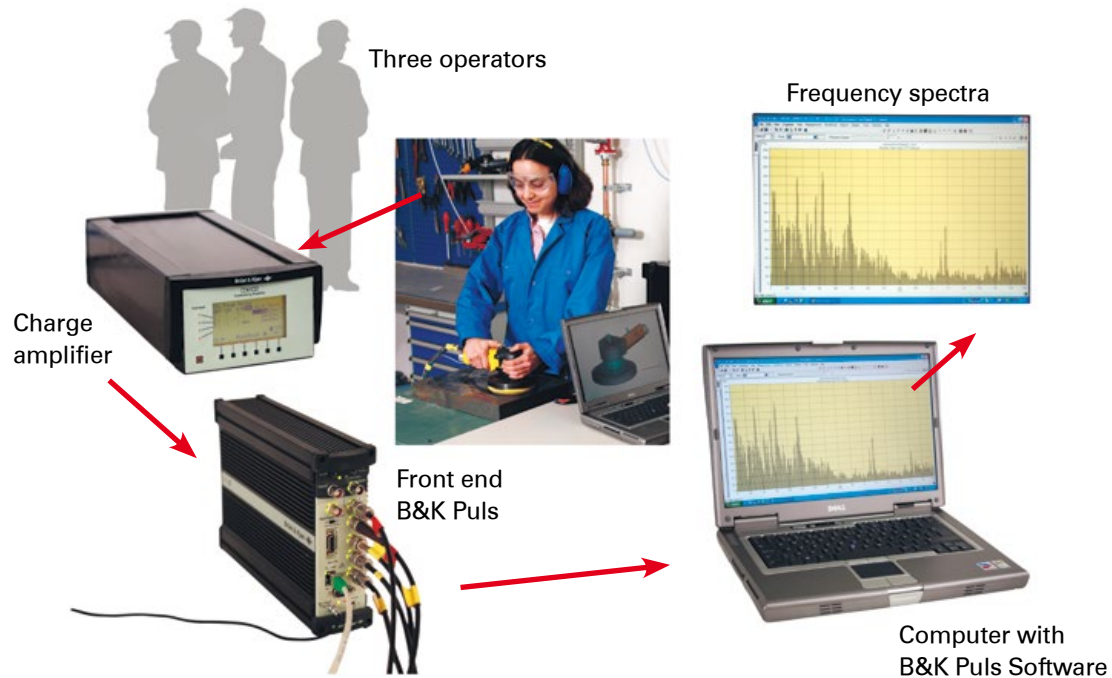

Fig. 3.14 Conducting laboratory measurements using ISO 28927

even more. From a hygienic standpoint it is of interest to locate the point with the highest vibration value. This is not an easy task.

This recommendation is understandable from the point of view of risk assessment, but you will never be able to repeat the measurement and it is pointless to compare measurements taken on different occasions.

Standards

Two sets of standards exist – one for operator exposure measurements and one for laboratory measurements. These standards have different purposes. If laboratory results are used to assess the health risk, caution should be taken. This will be discussed later under the heading “Evaluation of vibration”.

Exposure standards

ISO 5349 gives a dose-response relationship. The standard also contains a weighting filter used for both exposure and laboratory measurements. This filter has a damping of 6 dB/octave from 16 Hz. The result gained using this filter is a weighted acceleration value expressed in m/s^2 .

When the filter was designed it was assumed that the energy transmitted from the handle to the operator’s hand was a key parameter in the development of vibration-related injuries.

ISO 5349-2 gives guidelines on how to perform exposure measurements in an actual working situation.

Laboratory standards

The series of ISO 28927 specifies a laboratory method for measuring vibration emission of various hand-held power tools. Laboratory vibration measurements for electric tools are included in the general safety standards EN 62841.

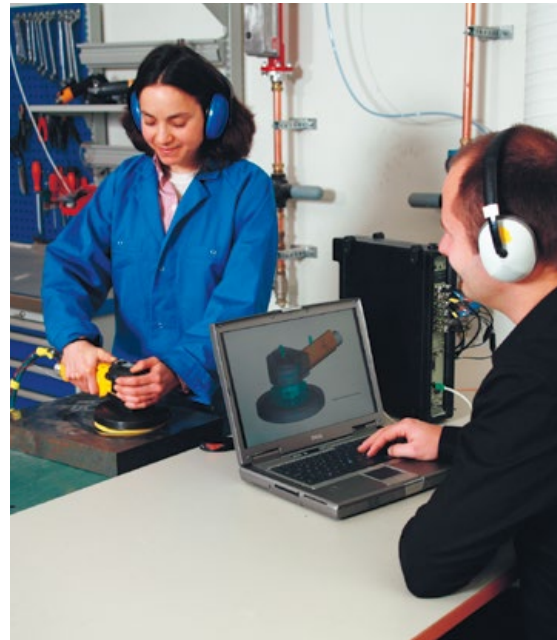

With a modern measurement system, multi-channel vibration measurements can be performed to gain a better understanding of the dynamic behavior of a machine.

Significant requirements in ISO 28927 and EN 62841 are: measurements in three directions and that the values obtained should reflect typical values in real use. To allow comparisons of results from different laboratories or different machine designs, the standards have been developed to give reproducible values. This has led to artificial loading of many machines. The selection of artificial load is designed to, as far as possible, give typical vibration values for the machine type in question during normal use.

The vibration value obtained from a laboratory measurement is a hand-arm weighted (ISO 5349) rms value. Three skilled operators load the tool during the measuring procedure.

Declaration of vibration emission values

According to the European Machinery Directive 2006/42/EC, the vibration emission values should be declared. The declaration must be made according to EN 12096, which states that the noise and vibration values should be declared using appropriate laboratory test codes.

The vibration emission value should be stated in the documentation delivered with the tool. If the value is below 2.5 m/s^2 , this should be stated. If the value is above 2.5 m/s^2 , the actual value must be given.

Vibration exposure

In July 2005, national legislation based on directive 2002/44/EC, the so-called Physical Agents (Vibration) Directive, came into force. The regulations stipulate the actions an employer needs to take to control exposure to vibration for his workforce.

The regulations include an action value and a limit value for the exposure to hand-arm vibration. Both values are exposure values integrated for an eight-hour working day.

Above the action value 2.5 m/s^2 the employer must take action to reduce exposure to vibration. Above the limit value 5 m/s^2 the employer must take immediate action to stop further exposure, find out why the limit was exceeded and ensure that it does not happen again.

The exposure action value 2.5 m/s^2 integrated over an eight-hour working day must not be confused with the emission value 2.5 m/s^2 , above which the manufacturer must declare the vibration emission value.

For more information, please refer to the Atlas Copco Pocket Guide *Vibration exposure assessment for industrial power tools*.

Vibration control

Power tool design involves a large number of parameters. The solution chosen reflects the designer's view of an optimal compromise on all parameters. One of these parameters is vibration.

The appearance of oscillating forces

These forces can arise in the tool itself, from the inserted tool or from the process in which the tool is used. A typical example of a power tool with built-in oscillating forces is a percussive tool where a piston is moved backwards and forwards in a cylinder. The motion is caused by compressed air acting on the front or back end of the piston, and at the same time acting with a reaction force on the machine housing. This oscillating force on the housing produces a vibration.

Other examples are internal unbalanced rotating parts. Vibrations can arise from shocks due to badly designed gears or from badly designed counter-weights in oscillating sanders. When designing power tools, oscillating forces in the design concept must be avoided or offset.

Such forces need not be of high magnitude – a force of just a few Newtons can be large enough to initiate an unacceptable vibration in a machine housing and its handle.

Vibration can also be caused by imbalance of the inserted tool. For example, vibrations in hand-held grinding machines arise mainly from the imbalance of the grinding wheel. This imbalance depends on the quality of the wheel and its precise fit on the tool spindle. Since the tolerances of the center



Grinding wheel imbalance is one of the main sources of vibration.

hole of the wheel are wider than those of the spindle, the production of wheels and spindles offers potential for reducing vibrations.

Another source of vibration is the work process, i.e., the interaction between the machine and the material it works on. A percussive tool, such as a riveting hammer,

may initiate vibrations in the structure it is being used on. These vibrations will be transmitted back into the machine.

Removing oscillating forces by design

It is important to identify oscillating forces at an early stage in the design process. In the following example the objective is to design a scaler for removing slag from welded parts. For this task a forward and backward motion was needed. The presence of oscillating forces is obvious and the design concept is that the forces should counteract each other. The principle is based on two opposing masses. The masses rest on springs that are clamped against the machine casing.

When the control is opened, the space between the two masses is filled with compressed air. Pressure on the trailing mass creates a force that accelerates it backwards. The leading mass is forced forwards in the

same manner. The amplitude of these two masses depends on the spring force acting on the masses, plus the inertia of the mass.

As shown in the figure, the trailing mass is larger than the leading mass. Thus, the leading mass has a larger amplitude than the trailing mass. The trailing mass forms a cylinder for the leading mass and there are outlets located in the front part of this cylinder. During forward movement of the leading mass, and when it passes the first of these outlets, the volume of compressed air between the masses starts to vent. At the same time, the flow of compressed air into the space is throttled. Due to the spring force, the masses now begin to accelerate towards each other. The space is sealed. Air pressure is built up again and the cycle is repeated. The spring forces, masses and degree of throttle are all calculated so that the resulting spring force on the casing is minimized. The declared vibration is below 2.5 m/s^2 .

Fig. 3.15 Two opposing masses reduce the oscillating force on the machine housing, in turn reducing vibrations.

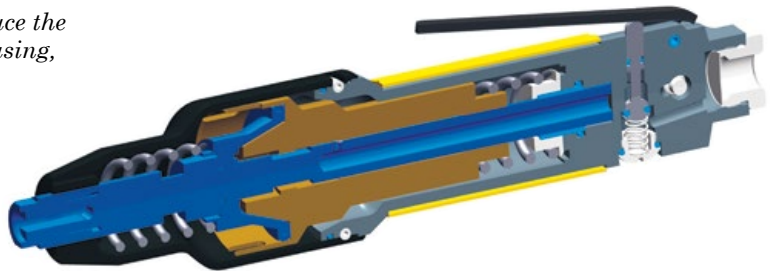

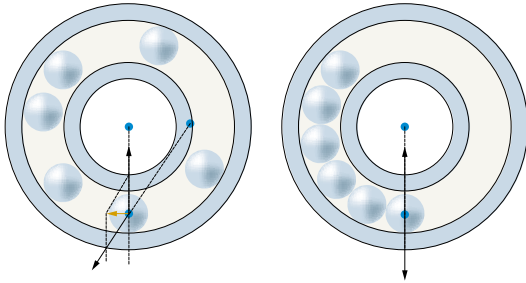

Fig. 3.16 The autobalancer automatically offsets wheel imbalance.

Imbalance forces

For grinding machines, the imbalance of the grinding wheel produces the dominating force which generates vibration. A unit has been developed to compensate for the imbalance. It consists of a number of steel balls that can move freely in a groove. This groove is integrated into the back flange and its center line aligns with the center line of the spindle.

The resonance frequency of the machine system held by human hands is about 15 Hz. Therefore, the frequency of the oscillating forces when the machine runs will always exceed critical. A rotating unbalanced mass will try to move the center of rotation away from the center line towards the unbalanced mass.

When this happens the balls in the groove will move in the opposite direction and offset the imbalance. This only takes a

fraction of a second. If the imbalance changes during the grinding process, the balls will quickly find new positions to compensate for the new imbalance.

Although this could offset the imbalance there are still forces acting on the machine, due to the fact that the balls are not acting in the same plane as the imbalance.

Handling the remaining forces

Two design options are available in this case with a rotating vector. One option is to increase the moment of inertia as much as possible. The other option is to isolate the handles from the machine.

Increase the inertia

We mentioned earlier that it is an advantage for the center of gravity of the tool to be as near the wheel as possible. One section of the tool situated near the wheel is, of course, the guard. The guard's mass is also located away from the center of gravity, giving high inertia.

When designing the guard, steps are taken to ensure that this component is tightly attached to the machine, and rigid enough to have a resonance frequency above the rotational frequency of the machine, i.e., in phase with the motion of the machine. At the same time, the guard must be adjustable so that the operator can easily change its position depending on the type of task to be performed.

From our simulations we could see that a rigid support handle with a mass at the end could also increase the inertia. On the other hand, an excessively large mass at the end caused increased vibration of the throttle handle. The alternative of isolating the support handle from the machine housing was also considered.

Isolation between source and hand

The most common way to do this is to isolate the handles with a mass spring system. Here two cases can be studied – one with a dominant direction of vibration, and the other with a complex vibration pattern in three directions and rotation as well.

Designing vibration isolation for the support handle is done by placing a spring element between the body of the machine and the handle. The handle itself is the mass. Thus, from a dynamic viewpoint, we disconnect the weight and moment of inertia of the handle from the machine. Accordingly, the center of rotation of the combined system is moved and, more importantly, the restraining effect of the handle's moment of inertia disappears. The machine will thus vibrate more than previously.

This effect can be studied by analysis in running mode. Vibration is measured at a number of different points on the machine and a computer animation of the tool's

geometry is obtained based on the values gained. During animation, the movement of the tool is greatly magnified, permitting study of the movements of different parts of the machine in relation to each other.

Here the handle is running out of phase with the machine and the vibration actually increases due to the dynamic disconnection of the support handle. The dynamic properties of the complete system, machine and handle, must be considered to avoid the resonance frequency of the total system matching the rotational frequency of the machine, because this will amplify the vibration.

Whether the rigid handle or the isolated handle is best from the point of view of hygiene is an interesting question.

However, covering a handle with a layer of visco-elastic material and claiming a reduction in vibration is wrong. The cut-off frequency for this design is above 300 Hz and most of the vibration energy in a power tool handle is below that frequency – thus, there is no reduction in vibration.

How far should we go?

Measures of this kind have resulted in a tool with vibration emission values below 2.5 m/s^2 . For a grinding machine with a rigid mass loaded support handle, readings were down to around 0.5 m/s^2 . We decided,

however, to provide the machine with a lighter handle, thus saving 0.4 kg in weight.

Isolation of vibration with a dominant direction

When designing the handle of a percussive tool, one of the tasks is to develop a damping system that can transfer high feed forces over a soft mass spring system. One source of vibration is the forward and return action of the impact piston. This action causes alternating pressures on the front and rear parts of the piston, with corre-

sponding oscillating reactionary forces on the machine housing.

The isolation built into the machine also has to be soft. The impact frequency for these tools often lies around 30 Hz, therefore the isolation system must have a natural frequency of its own that is well below this frequency.

The mass of the machine cannot be increased too much without adversely affecting the design, therefore the spring must be soft. The damping system on Atlas Copco RRH machines serves two functions. It acts



Fig. 3.17 Analysis of the grinder in running mode as seen from the front end. Above left: the machine is fitted with a stiff handle moving in phase. Below left: the machine is fitted with an anti-vibration handle moving out of phase. The question is, which solution is the best?

as a mass spring system to isolate vibrations, while conveying feed forces from the handle to the process.

The mobile cylinder and valve system are housed in a low-friction bearing in the machine housing. At one end of the cylinder there is a servo piston.

When the hammer is fitted with a riveting die and pressed against a rivet, the first task of the damping system is to transfer feed force applied to the handle to the rivet. When force is applied, the servo piston moves backwards inside the tool, gradually exposing an inlet hole into a volume in the handle. At the same time, it gradually closes an outlet hole. Air pressure in the volume in the handle then increases until there is a balance between the inlet and outlet flow.

Pressure acting on the damping piston produces a force that corresponds to the feed force. If the feed force increases or decreases, the system responds with a corresponding pressure change. This change has a limiting frequency of about 5 Hz.

With faster changes, such as the impact rate of the hammer, the system will not have time for air pressure changes in the volume. Thus, that volume of air now acts as a spring, the handle is a mass and the system has efficient vibration isolation

(weighted value $<2.5 \text{ m/s}^2$.)

This isolation system can cope with a wide variation of feed forces.

Evaluating vibration

In the European Machinery Directive 2006/42/EC, defining basic safety standards, it is stated that the manufacturer is obliged to declare vibration values. The values should be obtained by the use of an appropriate European standard (EN). ISO 28927 and EN 62841 and EN 60745 are used for pneumatic and electric power tools.

In the operator's instructions it should either be stated that the value is below 2.5 m/s^2 , or the actual value should be stated. The declared values are regarded as general information on the machine.

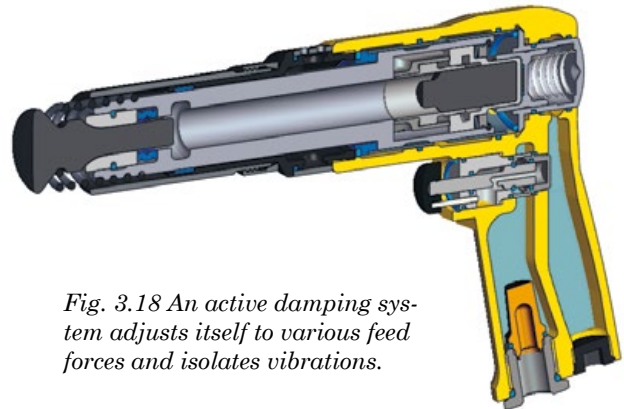

Fig. 3.18 An active damping system adjusts itself to various feed forces and isolates vibrations.

How can we use declared values?

We can compare machines of different designs or makes. It is probable that machines with low values in a laboratory test will have low values in an actual work situation. Anyone who has been involved in vibration measurements knows that these are difficult to perform in a laboratory situation. Vibration measurements are even more difficult to perform in a real work situation, and far more costly as well.

Bearing this in mind, it is natural that persons with the task of assessing the exposure risk will base their calculations on the declared values. The standards for measuring vibration, use just one transducer location. Yet along a handle, vibrations can vary by a factor of five. The standard figure is derived with an artificial load on the machine. Taking into consideration all types of inserted tools and the different ways in which operators use their machines, results from one transducer location will vary by a factor of three in practice.

The other important parameter is exposure time. A simple parameter one would think, yet difficult to estimate unless the task to be analysed is cyclical. In addition, operators often use several different machines, therefore the total accumulated exposure should be calculated.

Even standard ISO 5349 itself contains pitfalls. For example, the dose-response relationship is based on a limited number of research reports and is intended to give an indication of what is likely to happen when a number of operators are exposed over a period of several years.

Taking all this into consideration, one might conclude that the declared values cannot be used at all. It is our belief, however, that we can use this information for rough screening purposes, particularly when conducting multi-stressor analyses.

The CE standardization group working with the question of how to implement 2002/44/EC, the Physical Agents (Vibration) Directive has reached the same conclusion. In a technical report CEN/TR 15350 it is suggested that the first rough exposure assessment could be based on the declared values multiplied by a given correction factor.

For most industrial tools the correction factor is 1.5. For chipping hammers in fettling operations the correction is set to 2.

Another important correction is for tools with declared values below 2.5 m/s^2 . For those tools, 2.5 m/s^2 should be used as the declared value in exposure assessments even when a lower declared value is given.

In the following evaluation we use the guidelines from CEN/TR 15350. It should be

noted that declared values based on the revised versions of ISO 28927 and EN 62841 can in most cases be used without any corrections.

Exposure time

To evaluate vibration it is necessary to know the total duration of exposure. For a given workplace the actual exposure time should preferably be used. It should be noted that, when asked, operators tend to over-estimate the exposure time.

We compiled the following table by asking colleagues and others for their opinions on typical exposure times for different machine types. We have compared the results with the few measurements that have been made so far. For comparing different tools do-

Machine type	Hours per day	Spread +/- hours
Grinders	3	1.5
Drills	1	0.5
Chipping hammers	2	1.5
Riveters	1	0.5
Screwdrivers	2	1
Impact wrenches	1	0.5
Impulse nutrunners	2	1
Angle nutrunners	2	1
Stall torque nutrunners	1	0.5

Table 3.13 Typical exposure times per day for different machine types.

ing the same type of job, we recommend using the exposure time given in the table.

Calculation of dose

The dose-response relationship in ISO 5349 uses the time to early signs of finger blanching, versus acceleration, expressed as an equivalent.

$$A_{(8)} = (T/8)^{1/2} \cdot a_{hv}$$

where a_{hv} is the vibration in the process. In our rough estimation we use the corrected declared value for the machine in question and T is the actual exposure time, or total duration. In this screening procedure the average figure from Table 3.13 is used.

In our evaluation we use the action value from the Physical Agents (Vibration) Directive as the value corresponding to the score of 20. That value is 2.5 m/s². As a comparison, we find in the American Conference of Governmental Industrial Hygienists, 4 m/s² for daily exposure of 4 hours and less than 8 hours (note the time span).

To compare the vibration stressor with other stressors we use a curve arranged so that 2.5 m/s² gets a score of 20, and 5 m/s² gets a score of 50.

Bibliography

ISO 5349-1, Mechanical vibration – Measurement and evaluation of human exposure to hand-transmitted vibration – Part 1: General requirements

ISO 5349-2, Mechanical vibration – Measurement and evaluation of human exposure to hand-transmitted vibration – Part 2: Practical guidance for measurement at the workplace

ISO 28927 Hand-held portable power tools – Test methods for evaluation of vibration emission – Part 1-13

ISO 20643, Mechanical vibration – Hand-held and hand-guided machinery – Principles for evaluation of vibration emission.

EN 12096, Mechanical vibration – Declaration and verification of vibration emission values.

EN 62841-1, Electric motor-operated hand-held tools, transportable tools and lawn and garden machinery – Safety – Part 1: General requirements.

Directive 2002/44/EC of the European Parliament and of the Council of June 25, 2002 on the minimum health and safety requirements regarding the exposure of workers to the risks arising from physical agents (vibrations).

Directive 2006/42/EC of the European Parliament and of the Council of 17 May 2006 on machinery, and amending Directive 95/16/EC

CEN/TR 15350, Mechanical vibration – Guideline for the assessment of exposure to hand-transmitted vibration using available information including that provided by manufacturers of machinery.

Vibration exposure assessment for power tools, 9833 1508 01, a pocket guide from Atlas Copco Tools AB.

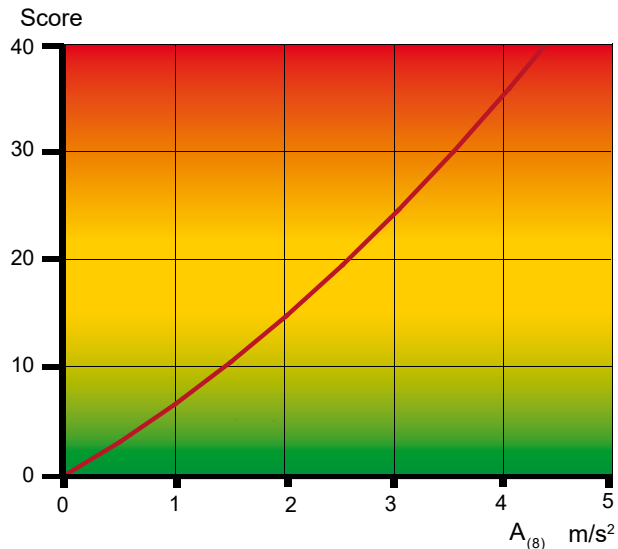

Fig. 3.19 Score for vibration using as input $A_{(8)}$, the vibration exposure integrated over an 8-hour working day.

Noise

Noise was the first environmental factor to be studied in the hand-held power tool industry. Typical sources are the common vane motor, escaping air, gears and, in the case of very silent machines, the vibrating housing itself. Sometimes the process is the dominant source. This has led to the development of machines with new, more silent processes.

What is noise?

What we perceive as sound or noise (depending on how we think of it) is a pressure variation superimposed on the atmospheric pressure. This pressure variation moves our ear drums, resulting in a nerve signal to the brain from the inner ear.

Pressure variations can be caused by the loudspeakers in our stereo equipment, by an oscillating plate, or by vibrations from a machine housing. Other sources can be a high velocity air flow, or a pulsating air flow



Acoustic testing using a test rig.

from a motor outlet. Noise can also be one single pressure pulse from an impact.

How do we measure noise?

A microphone converts the pressure variations into electrical signals that are amplified and fed to a computer. Noise can be analysed using an octave, 1/3 octave or 1/12 octave analysis. It can also be analysed as a narrow

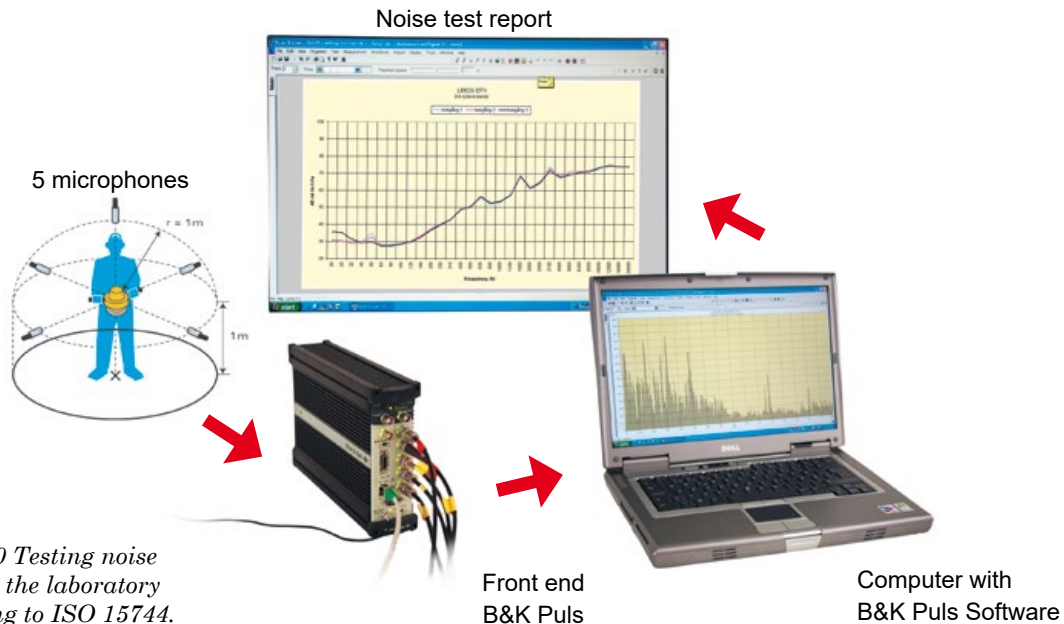

Fig. 3.20 Testing noise levels in the laboratory according to ISO 15744.

band frequency spectrum in cases where precise frequency information is important.

The most common way to present noise is to let the signal pass a broad band filter that will give a single figure. There are a number of filters available. A, B, C and D filters, for example. The characteristics of the A filter correspond to those of the human ear for low levels. However, the A filter is currently used at all levels to simplify the measurement process. The unit is dB(A).

Standards

There are standards for exposure measurements and laboratory measurements. Threshold Limit Values (TLV) for noise may differ from country to country.

The European Directive 2003/10/EC, the Physical Agents (Noise) Directive replaced the old 86/188/EEC and gives the limit value for 8 hours' exposure to 87 dB(A) with attenuation provided by ear protectors taken into account. The directive also gives an

upper and a lower action value of 85 and 80 dB(A), respectively, without ear protectors.

When an action value is exceeded the employer must take actions defined in the directive. Dose meters that can be carried by the operator during a full working day are available for conducting these measurements.

Laboratory measurements

A standard was developed in the 1960's for measuring the noise levels of hand-held power tools. It was the result of collaboration between Pneurop (the European Committee of Manufacturers of Compressors, Vacuum Pumps and Pneumatic Tools) and CAGI (the Compressed Air and Gas Institute, in the USA).

The European Machine Directive states that machine manufacturers are required to declare noise emission levels from the tools. If the sound pressure level is above 70 dB(A) the exact value and uncertainty should be stated. Furthermore, if the sound pressure level is above 80dB(A) the sound power should also be stated.

Even though both sound pressure levels and sound power levels are given in dB(A), they should not be confused. Sound power is calculated from a number of sound pressure measurements over a control surface. The methods to determine sound pressure and

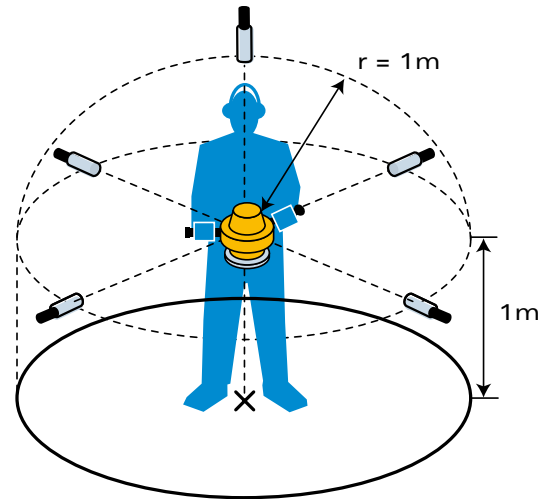

Fig. 3.21 Test surface containing five microphone positions.

sound power levels for pneumatic tools are given in the standard ISO 15744. Measurement methods for electric tools are given in ISO 62841.

Test procedure

The test object is held by an operator. The distance from the geometrical center of the machine to the microphones is 1 m. Four microphones are situated in a plane parallel to the floor, and one microphone is placed 1 m above the geometrical center of the machine. The average sound pressure level from the five microphones is the base figure for the declared noise emission value.

In the standard ISO 15744 the formula for calculation of sound power level is given as:

$L_w = L_p + 10 \lg (S/S_0)$ dB(A), where
 L_w = sound power level in dB(A)
 L_p = average sound pressure level from 5 microphone positions, in dB(A)
 S_0 = the surface of the hemispherical/cylindrical control surface, where sound is passing, in m^2
 S_0 = reference surface of $1 m^2$
 S_0 is $4\pi m^2$, therefore $10 \lg (4\pi) = 11$

A sound power value is 11 dB(A) higher than the corresponding average sound pressure value.

Loading of the machine

Some machine types are run on a loading device while others are not. When a loading device is used, the noise it generates should be at least 10 dB lower than the noise from the power tool being tested, in each octave band that influences the dB(A) value.

Declaration of noise emission values

The noise test standard gives the type of test procedure that should form the basis of the declared value. The standard also gives a method of coping with uncertainties arising from variations due to the test method and variations in production. The total uncer-

tainty declared together with the measured value is 3 dB(A). You can always argue that 3 dB(A) is a very approximate figure, and that for some tools the uncertainty is less. It is also true that there are other international declaration standards where the tolerance is calculated for every machine.

Noise control

Noise hitting the human ear drum or a microphone is almost always a combination of sounds from several sources. When controlling noise it is important to know the sources. It is even better if the relative loudness of the sources is known because this knowledge allows priorities to be set.

If, for example, there are two sources with the same level and it is possible to remove one completely, the total level will only be decreased by 3 dB. If there are a number of sources and one is removed it might fail to show up in the readings altogether, depending on its frequency and relative loudness. When testing in the laboratory, it is recommended that the sources are identified in the machine and, if possible, isolated for a more accurate interpretation. Measuring equipment, such as intensity meters, can be very useful. We can start by looking at the machine itself, not taking the process noise into account. In a

pneumatic grinder, for example, there are several sources. If the grinder is equipped with a vane motor, this is the loudest source. Usually it is most efficient to start noise control work at the main source

The vane motor

A vane motor consists of a rotor with a set of vanes rotating eccentrically in a cylinder. The motor has an inlet for compressed air and at least one outlet, normally in the form of holes or slits in the cylinder mantle.

When a vane passes the outlet, compressed air passes out at high speed. This creates a pressure pulse outside the cylinder,

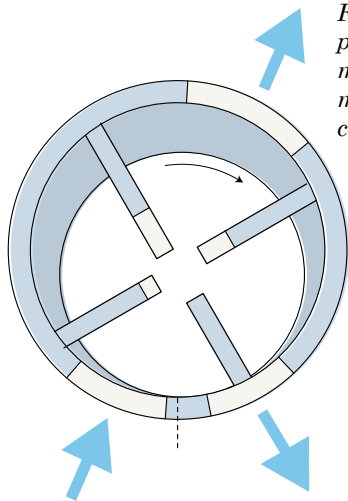

Fig. 3.22 The outlet pulse from the vane motor is one of the main acoustic sources for the motor.

moving away from the cylinder at the speed of sound (340 m/s). The next vane starts up the next pulse in the same manner.

When the motor runs, a noise will be created with a fundamental frequency equal to the rotor speed multiplied by the number of vanes. A narrow band analysis of this noise will show the fundamental frequency and a number of harmonics. In other words, the signal is not a sine wave but a more complex signal. However, the fundamental frequency is often dominant. One way to treat this noise is to arrange the rows of vanes in the rotor asymmetrically. Another option that can be chosen at the same time is to design the outlet in a way that lowers the air flow gradient, since the noise level decreases when the change in flow decreases.

Muffler

When the motor has been optimized according to all parameters, including power, efficiency, weight, etc., the remaining noise can only be muffled away.

The motor is protected by a housing. Part of the housing is designed to act as a muffler. If a pipe is connected to the outlet, the noise from the open end of the pipe can be controlled by the length of the pipe. If the pipe length is equal to a wave length or a half wave length of the fundamental

frequency, the pipe will hardly influence the noise at all. If the length of the pipe is equal to one-quarter or three-quarters of a wavelength, a considerable reduction in noise will be experienced.

This is a reactive muffler. As routine procedure, we check the length of our mufflers to take advantage of the phenomenon mentioned above, but we also incorporate resistive mufflers into our machines. These mufflers consist of a volume of space and a restriction in the outlet. The larger the volume, the greater the noise reduction effect. However, this conflicts with the size and weight of the tool.

The greater the pressure drop in the restriction,

the greater the noise reduction. This conflicts with the power of the tool and the generation of aerodynamic noise in the outlet. As usual we need to find a compromise.

A grinder equipped with a governor has a low air flow at idling speed and a high air flow at full power. The muffler must be able to cope with these two extremes and everything in between.

Many mufflers for these machines have been equipped with a restriction that can adjust itself to the actual flow.

The restriction is designed with a

spring-loaded piston. As the flow increases, the piston moves and opens more

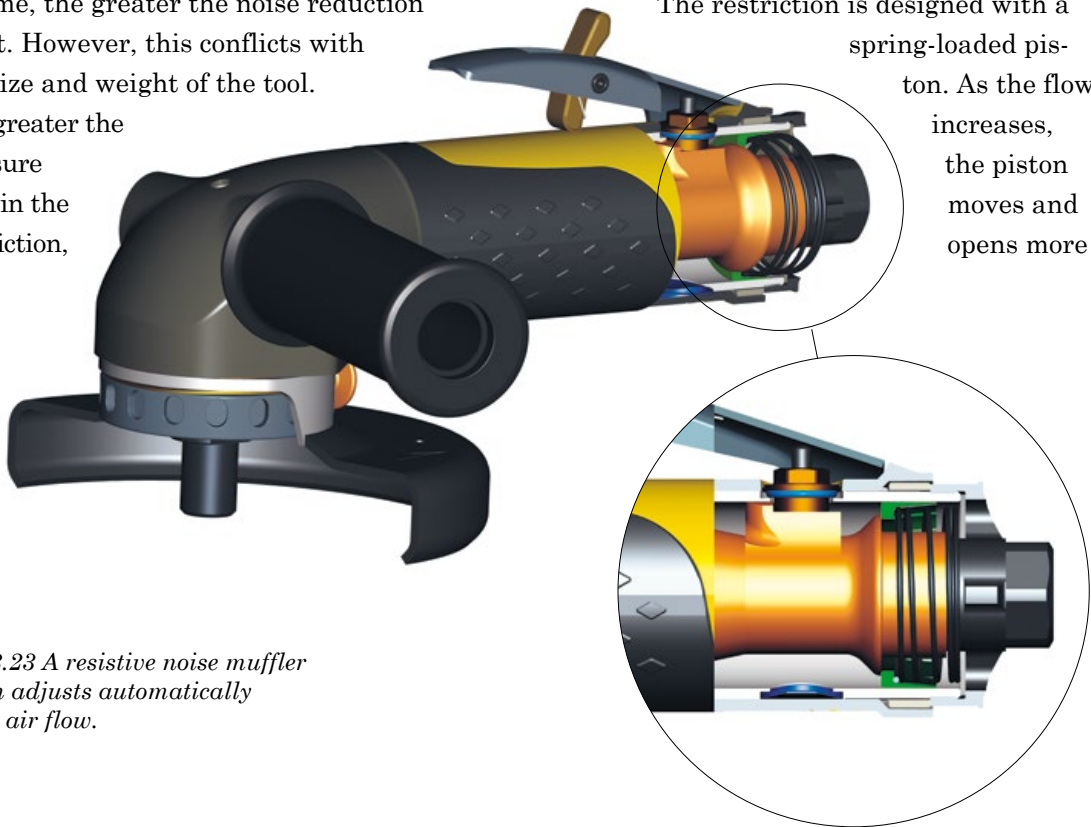

Fig. 3.23 A resistive noise muffler which adjusts automatically to the air flow.

outlet holes. This is done with a minimum increase of pressure drop, irrespective of air flow.

Another advantage of this design is the reduction of stop noise. When the grinder is stopped the air flow rapidly decreases. A conventional muffler will lose the pressure drop in the restriction and most of its damping performance. The grinding wheel with its stored rotational energy will take a few seconds to stop. During this period the motor is actually sucking air through the outlet and generating a lot of noise. The

piston in the new design shuts the outlet and there is no stop noise.

For nutrunners and other machines which only work for short periods at a time, it is more efficient to fill the muffler with cellular materials that break up the currents in the air stream, thus reducing noise levels.

Aerodynamic noise

The pressure drop in the outlet of the muffler will accelerate the air and increase its velocity. Sound power generated is a function of the outlet speed to the power of six.



An oil cushion eliminates high-frequency noise from the process.

Therefore a low outlet speed must be maintained. Aerodynamic noise has a high-frequency broad-band content. The smaller the outlet holes, the higher the frequency. Very tiny holes can take the spectrum out of the hearing range and, in that sense, reduce the dB(A) reading. However, the risk of clogging must be considered.

Noise transmitted by vibration

Wheel guards can be a problem in this respect. The transmitting surface is quite large. For noise reduction purposes, we want to know if the natural frequency of the guard is above or below our typical running frequencies. Whatever our aim, we must avoid running the machine at the resonance frequency of the guard.

Process noise

Noise generated by the process is often very difficult to eliminate. Sometimes we can change the machine type and, as a result, change the process. Changing from impact wrenches to stall torque machines is one example.

Some customers may prefer to keep the impact wrenches because the tools are low in weight with low reaction torques. In such cases, impulse nutrunners may be selected. Instead of using a mechanical blow to set

the nut, the impulse tools are buffered by a hydraulic cushion.

Technically this is the same as filtering the blow to eliminate its high frequency noise emissions. When this blow enters the structure in which the joint is located, the natural frequencies in the high frequency domain will not be excited. This leads to less process noise.

Evaluating noise

Again the question: Can we use the declared noise levels in our comparison of the effects of different stressors? For some machine types extensive variations can occur in the process noise. For machines like grinders, in most cases the process noise is dominant.

The only way to get around this dilemma is to advise the user that the noise exposure can be all the way from the dose calculated using the declared value and the estimated average exposure time, to a much higher dose depending on the workpiece and individual operator's working habits. The simple fact that different operators assume postures giving different distances from noise source to ear can influence the exposure level by 6 dB(A).

In the noise test the test situation has been defined as the average level from five microphones at a distance of 1 meter from

the machine. It can be argued that 1 meter could be too far between the machine and the operator's ear. Comparisons between the average level and measurements made at the operator's ear for the same object are, however, very close due to the direction of the noise scatter. Less noise is scattered in the direction of the operator because the exhaust air is directed away from the operator.

Calculation of dose

The declared noise level to which the operator is exposed during the assumed average time is recalculated to an 8-hour equivalent level.

$$L_{eq(8)} = 10\log[1/8(10^{L/10}T)]$$

L = noise level in real use, estimated with the declared value.

T = assumed exposure time

Typical exposure times per day for different machine types can be found in Table 3.10 The $L_{eq(8)}$ is then compared with a Threshold Limit Value (TLV) for 8-hour exposure. In our stressor comparison we assume 85 dB(A) to give a score of 20.

Exposure time

We use the same average exposure time as for vibration. The value can be found in Table 3.13.

Bibliography

ISO 3744, Determination of sound power levels of noise sources using sound pressure. Engineering methods in an essentially free field over a reflecting plane.

ISO 15744, Hand-held non-electric power tools – Noise measurement code – Engineering method (grade 2).

EN 62841, Electric motor-operated hand-held tools, transportable tools and lawn and garden machinery - Safety

Directive 2003/10/EC of the European Parliament and of the Council of 6 February, 2003 on the minimum health and safety requirements regarding the exposure of workers to the risks arising from physical agents (noise).

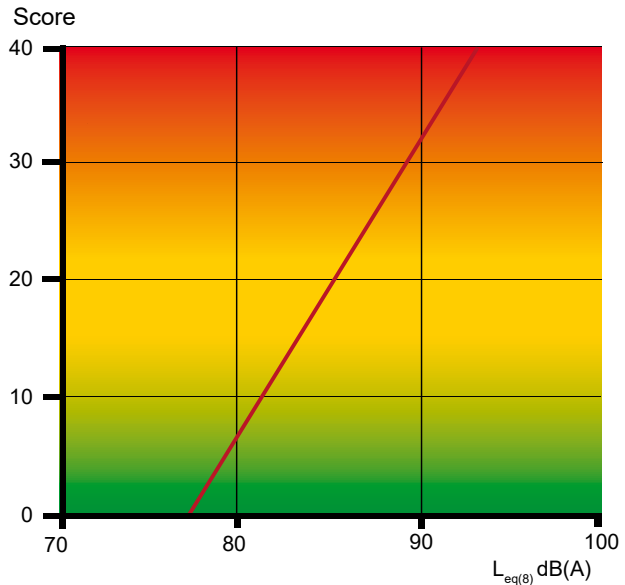

Fig. 3.23 The score for noise can be found using L_{eq} for an 8-hour working day as the input.

Dust and oil

The influence of these two factors on the operator depends very much on the process itself. The dust particles and oil mist of interest for a hygienic evaluation are so small that they will remain airborne for a long time. If the ventilation in the workroom is poor, high concentrations may occur.

What is dust and oil mist?

Pollutants in the form of airborne particles can occur in both solid and liquid form and can vary in size. A large amount of particles floating in a bearing medium is called dispersion. When the bearing medium is air, the dispersion is known as aerosol.

A fixed aerosol contains solid particles which, when larger than $0.5\ \mu\text{m}$ ($1\ \mu\text{m} = 1/1000\ \text{mm} = 0.00004\ \text{inches}$) are called dust, and when smaller, smoke. Dust is normally created by mechanical finishing of materials,

like grinding or sanding, while smoke is the product of incomplete combustion.

An aerosol containing droplets of liquid is called fog when the size of droplets exceeds approx. $0.5\ \mu\text{m}$ and smoke when the droplets are smaller. The droplets can be formed when a liquid is dispersed during, for instance, spray painting or lubrication of pneumatic tools.

Respirable aerosol

The most dangerous particles in an aerosol have a diameter between $0.1\ \mu\text{m}$ and $5\ \mu\text{m}$.

Particles $>5\ \mu\text{m}$ are filtered off in the nose. Smaller particles have the ability to follow inhaled air into the deepest inner cavities of the lungs, the alveoli, and remain there, although some are exhaled again. This dust is termed respirable.

Inert particles

It is in the alveoli that gas exchange takes place. The body emits carbon dioxide and takes up oxygen. Thus, it is extremely important that the alveoli do not become

coated with dust or damaged by aggressive dust particles. Inhaled particles will be transported back and swallowed or handled by the lymph system. Some will be encapsulated in the alveoli and reduce their capability to exchange oxygen and carbon dioxide. Most of the dust we inhale is harmless or inert.

Toxic particles

Dust from certain metallic substances such as manganese, vanadium, cadmium and beryllium can give rise to severe inflammation of the lung tissues. This condition is similar to pneumonia, varying in seriousness depending on the degree of exposure and the type of dust involved. Dust from a number of substances penetrates the wall of the alveolus and is carried out in the lymph system. These substances include, for instance, lead and cadmium, which can give rise to symptoms of intoxication and which can only be removed from the body very slowly.

Drop velocity

Particles in aerosols of interest have a very slow drop velocity. For example, for spherical particles with the density of water, 1g/cm^3 , drop velocity in air at a temperature of 20°C is shown in table 3.14.

The table illustrates that respirable dust remains floating in the air for a long

time and, as mentioned previously, the concentration in the operator's breathing zone depends heavily on the ventilation of the work room.

If the operator works in a fettling booth and air is sucked away from it, this will create an air flow past the operator. If the velocity exceeds 0.5 m/s , the air flow will be experienced as a draught by the operator.

If dust is generated by the process, clouds of dust with a velocity of higher than 0.5 m/s can move towards the operator and expose him. The dust clouds can then turn back into the fettling booth and move past the operator again. Typical for the scatter of respirable dust is that the particles follow the motion of the air in the room.

An efficient general ventilation system will reduce the amount of particles in the air. An inefficient system will increase the number of particles and oil mist during the working day. To find out the degree of operator exposure,

Dia. (μm)	Drop velocity (cm/s)
1	0.003
5	0.07
10	0.3
50	7
100	30

Table 3.14 Drop velocity is highly dependent on particle size.

measurements must be made over long periods of time to obtain an average figure.

How do we measure respirable aerosol?

To measure respirable aerosol, we have exposure measurements and laboratory emission measurements.

Exposure measurements

Due to the fact that dust is scattered in an irregular pattern, measurements must be performed over a long period up to full working days.

The operator is provided with a light weight air pump with approximately the same flow rate as normal breathing. A filter is mounted on the operator's shoulder and the pump draws air through the filter, which retains airborne particles. A cyclone can be used prior to the filter, which permits only

respirable particles to pass through. After the test the filters are analysed. The average amount of particles in mg/m^3 is determined, as well as size distribution and material content. The result is compared with some Threshold Limit Values, for example those of the American Conference of Governmental Industrial Hygienists.

Laboratory emission measurements

In 1987, Pneurop, the European Committee of Manufacturers of Compressors, Vacuum Pumps and Pneumatic Tools, published a series of standards relating to procedures for the measurement of dust emissions from hand-held power tools.

These standards introduce a method where the machines are placed in a laminar flow. Emissions of particles from a defined process using different machine types are measured. There is a description of how to create the air flow and how to take samples.

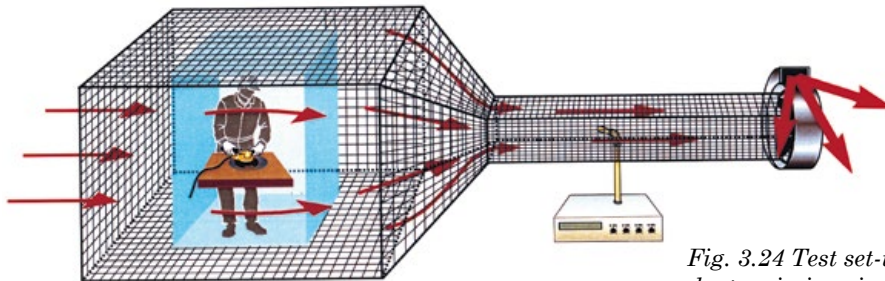

Fig. 3.24 Test set-up for measuring airborne dust emissions in the laminar flow.

Dust control

The most efficient way to extract dust is to remove it by suction from as near the source as possible. For power tools this means that a dust collector should be integrated into the machine. Thus, less airflow is required to ventilate the work booth, the heating cost is less and the method creates no draught for the operator. If the system is capable of removing dust, it will also cope with oil mist. Oil is, however, best treated in the machine itself, i.e., oil-free machines.

Collecting dust as close to the source as possible

There is a big difference between blowing air and sucking air. If air is blown through a nozzle, with a diameter D , at a speed of V , the air velocity at $10 D$ will be $0.1 V$. If air is sucked into a nozzle with diameter D , at a speed of V , the air velocity outside the nozzle will be $0.1 V$ at a distance of D from the nozzle. For this reason, dust should be removed by suction near the point at which it is created.

Extraction hoods

The most common extraction hoods have brush lips around the periphery. Part of the hood is cut away, enabling the operator to see the disc in operation. During the work cycle the spray

generated by grinding is arrested by the brush lip. The brush lip limits the spread of grinding spray and dust. The flow velocities of the inlet air can thus be kept low and the system can operate with a low flow.



Fig. 3.25 The extraction hood with brush lips is the most common type.

Suction hose

The suction hose is one of the most important components in any dust extraction system. While having a considerable effect on the system's ease of operation, it is also the component which produces the greatest pressure drop in the system.

Pressure drop and ease of operation are two contradictory criteria and the final choice is always a compromise. The extraction hood requires a specific airflow to achieve sufficient intake velocity for efficient extraction.

The pressure drop in the hose is determined by the diameter and length of the hose. During installation there are always discussions between the customer and the supplier regarding the length of the suction hose. The customer naturally wants to work over the widest area possible, and the supplier has to explain that extending the length of the suction hose will merely result in poorer suction and extraction capability.

For the operator, the hose is just another restriction on his mobility. Therefore he wants it to be as thin and flexible as possible. One alternative is to have a small diameter hose close to the tool and change to a larger diameter hose as soon as possible.

Fig. 3.26 Air velocity outside a blowing and a sucking nozzle.

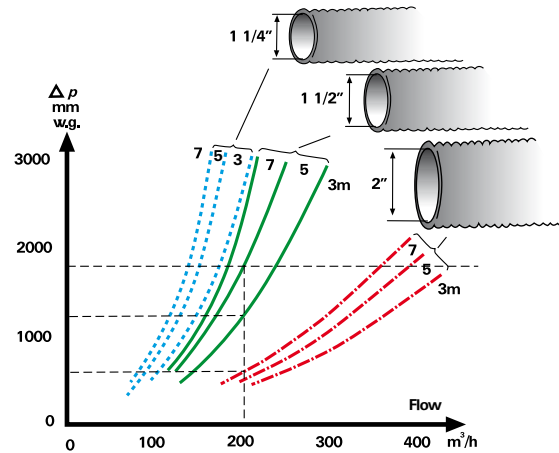
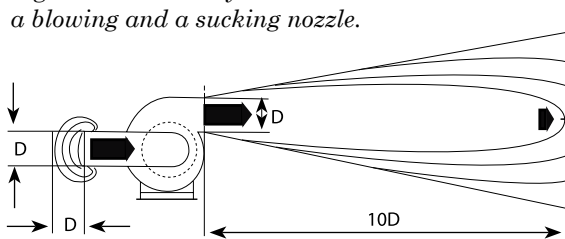

Fig. 3.27 Plot of pressure drop in hoses for different diameters, length and air flow.

Swing arm

In fixed extraction installations, the suction hose should be supported on a swing arm since this is the best way to keep the hose clear of the workshop floor. It is particularly important to avoid people stepping on it, since a deformed suction hose will generate a much higher pressure drop than an undamaged hose with the same flow.

When different hose dimensions are used it is a common practice to attach the thinner hose permanently to the machine and to have a connection between the hoses for easy change of machine.

The one disadvantage of this system is that the hoses take up a lot of space in the

tool cabinet. Many workplaces have therefore installed special tool racks where such tools can be stored when not in use. This approach makes maintenance of the suction components easier, as it is possible to see directly which parts need to be replaced.

Vacuum valve

Dust extraction systems are often designed with more extraction points than the vacuum unit can handle, if all are used at the same time. For this reason, only the extraction point in use should be connected to the main extraction pipe.

Connection of the suction point to the extraction pipe is done by means of a valve that recognizes the flow of air to the machine when started and automatically opens the connection to the main extraction pipe.

Extraction pipe installation

Two rules of thumb are used to determine the size of an extraction pipe. The minimum velocity required to prevent the accumulation of dust at bends in the system is 10 m/s. The maximum acceptable velocity with regard to pressure drop is about 40 m/s. This generally provides three extraction points for each branch pipe. The suitable diameter for horizontally aligned, thin walled steel pipe is 100 mm.

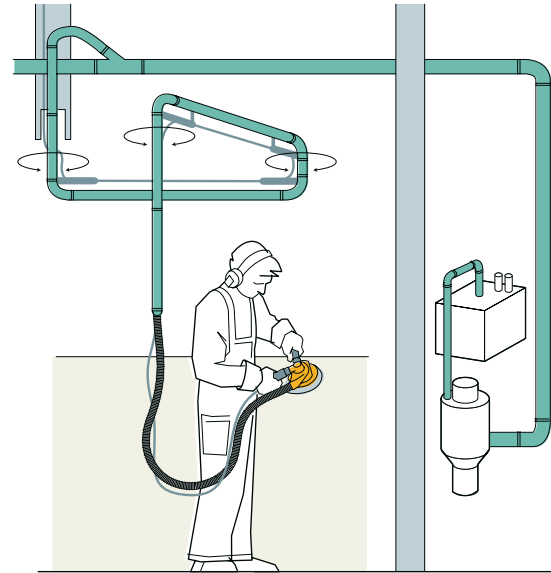

Fig. 3.28 Vacuum system

Filter and vacuum source

The extraction pipe ends with a filter unit, which often consists of a cyclone followed by a fiber filter and a barrel where the dust is collected.

The vacuum source can be a multi-stage fan, a Roots pump, or a pump of another design. Every vacuum source has a vacuum-flow characteristic. A pipe, hose and dust collector system creates a certain pressure drop for a certain flow. The manufacturer states the required flow through the dust collector for efficient dust extraction.

When a vacuum unit is matched to an extraction system two plots are made: the

vacuum-flow of the unit and the pressure drop-flow for the system. In this plot the vacuum and pressure drop are plotted on one axis and the flow on the other. The intersection is the balance or working point for the system. It should be checked that the flow at this point matches the recommended flow for the tools used.

Oil control

Thirty years ago machine tool designers began developing vanes that could run against the cylinder wall without lubrication. This development was motivated by the fact that oil used to lubricate the vanes was emitted in aerosol form in the exhaust air. It often entered the operator's breathing zone, and could cause harm by irritating the skin.

Development followed two paths. One path was to create a more efficient lubrication system that could minimize the amount of oil needed. The product is called Dosol.

The other path was to design a vane material that did not require oil. Historically the vanes were made of bakelite reinforced with cotton fiber. The vanes run very fast along the air motor cylinder wall and speeds of up to 30 m/s are common. The forces between the cylinder wall and the vane are high. The friction coefficient must be kept low to avoid high temperature and wear and this

has traditionally been done with oil. When run completely dry, it was not uncommon for vanes to have lifetimes of just minutes.

After extensive testing with customers and in the laboratory, in 1990 new types of vanes were introduced that require no lubrication. Made from a composite with low friction additives, these vanes are used in screwdrivers, nutrunners, drills and other tools that are used intermittently. Performance data match those of tools with traditional vanes.

To date, no vane material has been found that can replace conventional vanes in tools running at high vane speeds for prolonged periods, e.g., grinders. However, in the largest grinder range, we now offer turbine grinders. They require no lubrication and are thus a major step forward in terms of ergonomics.



Modern turbine grinders can preferably be run on non-lubricated air.

Evaluating dust and oil

From a power tool manufacturer's point of view, it is very difficult to evaluate dust and oil. However, one thing is clear – if the machine does not need oil the weighting factor for comparison with other stressors is zero.

To evaluate dust and oil in an aerosol form we need to know more about the workstation, its ventilation, the process, and much more. This is unique information. In order to compare stressors we can establish rules of thumb based on our experience of how our machines are used.

Bibliography

ISO 4225, Air quality – General aspects – Vocabulary

ISO 12141, Stationary source emissions – Determination of mass concentration of particulate matter (dust) at low concentrations – Manual gravimetric method

Type of tool	High working pace						Low working pace					
	Dust		Oil				Dust		Oil			
	Spot suction Yes	No	Lub free tool		Lubricated tool		Spot suction Yes	No	Lub free tool		Lubricated tool	
Air piped away			Direct outlet	Air piped away	Direct outlet	Air piped away			Direct outlet	Air piped away	Direct outlet	
Rough grinder	8	20	1	1	6	10	4	10	1	1	3	5
Die grinder	4	10	1	1	3	6	2	6	1	1	2	4
Sander	6	20	1	1	4	8	3	10	1	1	2	4
Chipping hammer	4	8	1	1	2	4	2	4	1	1	1	2
Riveting hammer			1	1	2	4			1	1	1	2
All drills	2	8	1	1	3	6	1	4	1	1	2	4
Impact/impulse nutrunner			1	1	3	6			1	1	2	4
Nutrunners			1	1	3	6			1	1	2	4
Screwdrivers			1	1	3	6			1	1	2	4

Table 3.15 Score for airborne dust and oil can be found in this table.

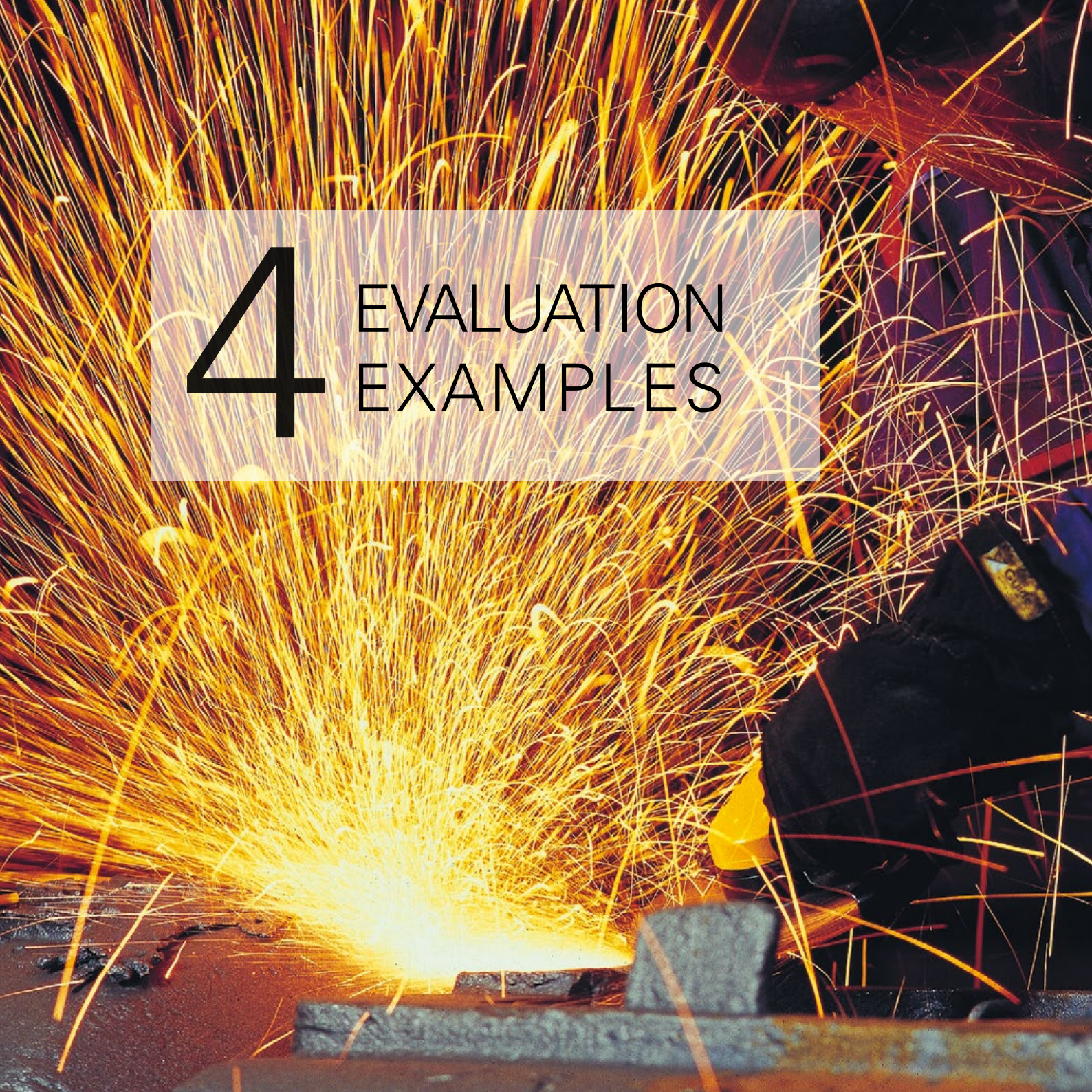

4 EVALUATION EXAMPLES

Grinder GTG 40 F085



The relevant variables for the grinding machine can be selected from Table 3.1 (page 71).

This powerful (4.5 kW) grinder is regarded as a machine for male operators. The motor is an air-driven turbine.

HANDLE DESIGN

Variables	Weighting factors (a)	Preferred (0)	Acceptable (1)	Permitted (3)	To be avoided (5)	Score
Circumference trigger activated	low force a1=1	120 mm				0
Circumference trigger open	a2=1	170 mm				0
Length	low force a4=1	105 mm				0
End marking	a6=0.5	smooth				0
Adjustability	a7=0.5		no			0.5
Support surface	a8=0.5		no			0.5
Viscoelastic coating	a9=0.5	yes				0
Friction and ventilation	a10=0.5	good				0
Total score:						1

Table 4.1 Evaluation of handle design for the Grinder GTG 40 F085.

EXTERNAL LOAD

Typical loads for grinding machines are selected from Table 3.9 (page 81) in the chapter on external load. Since the GTG 40 is a powerful pneumatic angle grinder, it can be estimated that the feed force is at the higher end of the given spread. In this evaluation feed force is estimated to be 90 N. According to chapter 3, 70% of the feed force is provided via the support handle. The force acting on the support hand is therefore 63 N.

Assuming the front of the grinding wheel is in contact with the surface, ulnar flexion torque on the support hand can be calculated. It will be 90 mm times 63 N, 5.7 Nm.

WEIGHT

When grinding on horizontal surfaces, the weight of the tool means that lower feed forces are required. However, we never add unnecessary weight to the designs. The evaluation diagram gives a score of 15 for the weight of 3.8 kg.

TEMPERATURE

Expanding compressed air in the turbine lowers the temperature of the exhaust air which, in turn, lowers the temperature of the machine housing. The support handle is plastic to prevent the low temperature from being transmitted to the operator's hand. A plastic spacer isolates the throttle handle from the machine housing.

Evaluation using the method suggested in the chapter on temperature gives a handle temperature of 20°C and, thus, a score of 1.

SHOCK REACTION

The only event which can cause a shock reaction when grinding is a jammed cutting wheel. This shock is, however, relatively minor. Thus, shock reaction does not apply for grinders.

VIBRATION

At the design stage, the dynamic properties of the machine in a state of imbalance

Force/Torque	MVC N/Nm	Safety factors			Reduced MVC	Real load N/Nm	Real / Reduced	Score
		Speed	Frequency	Duration				
Trigger	380 N	a1=1	a2=0.6	a3=0.5	114 N	16 N	0.14	1
Push down straight arm	600 N				180 N	63 N	0.35	3
Ulnar flexion	15 Nm				5 Nm	5.7 Nm	1.1	26
Total score:								30

Table 4.2 Evaluation of external load for the grinder GTG40 F085.

were simulated by fitting a wheel with a predetermined degree of imbalance. The rotating force vector from the imbalance was offset by an Autobalancer incorporated in the flanges on the back of the wheel. Not being in the same plane, the remaining pair of forces was prevented from causing the machine to vibrate by the high inertia of the wheel guard, which is in a locked position when grinding. The declared value is $<2.5 \text{ m/s}^2$, therefore we use 2.5 corrected with the factor 1.5. This estimated process vibration together with the average duration of operation of 3 hours, from Table 3.10 (page 82) in the chapter on vibration, will give a vibration exposure of:

$$A_{(8)} = (3/8)^{1/2} \cdot 3.75 = 2.3 \text{ m/s}^2$$

From the curve in chapter 3, a score of 18 can then be found.

NOISE

The main source of noise from the machine is the outlet from the turbine. This gives broad-band, high-frequency noise, without any dominating single frequency. The best solution is a resistive muffler, comprising a volume and pressure drop device, located in the outlet. Resistive mufflers are most efficient in the high-frequency range. From the

chapter on noise, the evaluation correlated with the declared noise level will be:

$$L_{\text{eq}(8)} = 10 \cdot \log (1/8 \cdot 10^{L/10} \cdot T)$$

For the GTG 40 with a declared noise level of 85 dB(A), and a duration of operation of 3 hours, this is calculated to be 81 dB(A).

Using the diagram in chapter 3, this scores 10.

It must be noted that this level may be much higher during the actual grinding process, as indicated in the evaluation diagram.

DUST AND OIL

This machine is lubrication free but the air is not piped away (score 1).

The degree to which the operator is exposed to dust depends on the properties of the workpiece, and the design and ventilation of the workstation and the workshop in general. Since the machine is very powerful, it is capable of removing large amounts of material, and this in itself creates dust.

From Table 3.15 (page 132) a score of 10 can be found if the working pace is assumed to be low. The total score for dust and oil will then be 11.

Here, a warning must be given regarding grinding material containing toxic

substances. A dust extraction system in combination with a protective mask may be the only solution. Dust as an ergonomic factor can score 10-40.

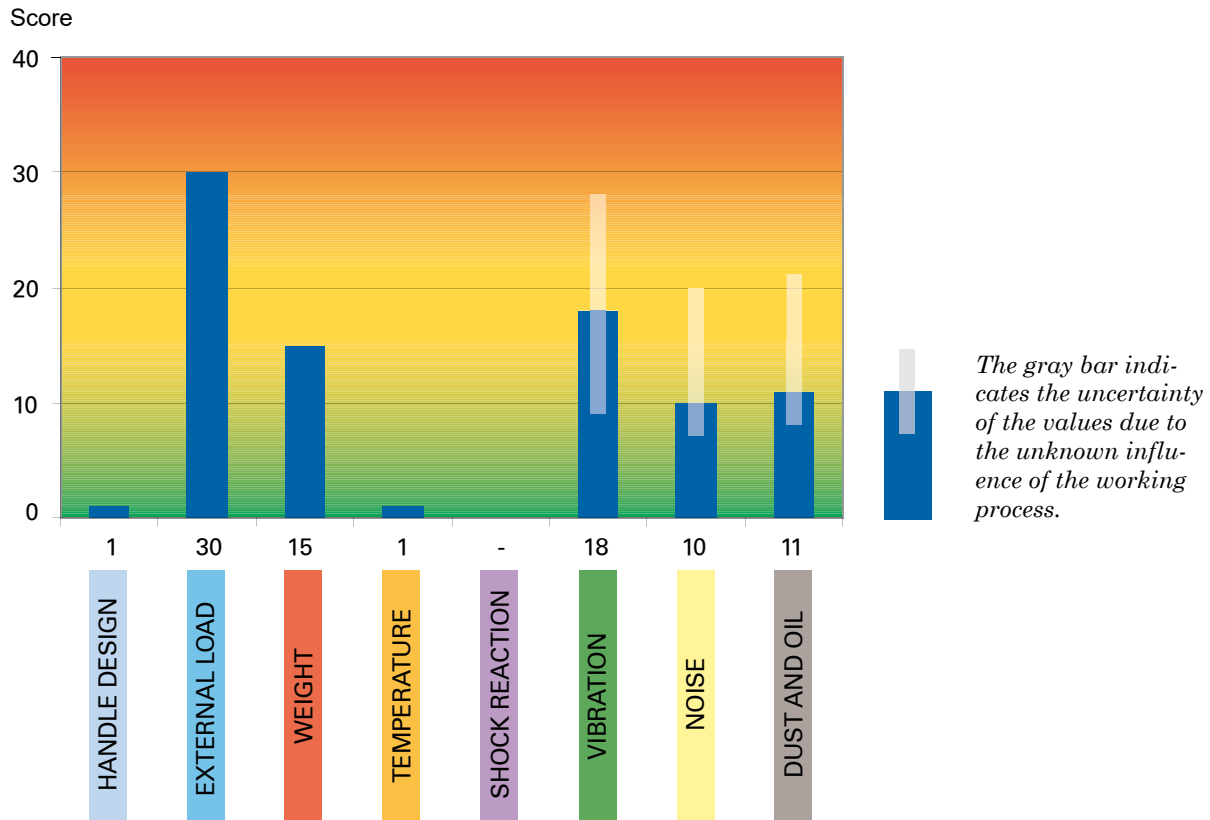

Fig. 4.1 Bar graph showing the overall result for the evaluation of the Grinder GTG 40 F085.

Drill

LBB 26 EPX-060



The relevant variables for the drill can be selected from Table 3.1 (page 71). With a power output in the upper range (500W),

the LLB 26 drill is regarded primarily as a tool for male operators. The machine is driven by a lubrication-free vane motor.

HANDLE DESIGN

Variables	Weighting factors (a)	Preferred (0)	Acceptable (1)	Permitted (3)	To be avoided (5)	Score
Circumference trigger activated	high force a1=2	130 mm				0
Circumference trigger open	a3=1	148 mm				0
Length	high force a4=2	105 mm				0
End marking	a6=0.5	smooth				0
Adjustability	a7=0.5		no			0.5
Support surface	a8=0.5	yes				0
Viscoelastic coating	a9=0.5	yes				0
Friction and ventilation	a10=0.5	good				0

Total score: 0.5

Table 4.3 Evaluation of handle design for the Drill LBB 26 EPX-060.

EXTERNAL LOAD

When drilling, the external loads are torque and feed force. Torque depends on the drill speed selected. The drill selected here is a 6,000 rpm tool with a maximum measured torque of 1 Nm. Tools with higher speeds give lower torque. The torque is experienced as a supination torque. For tools with lower speeds the operator uses the left hand for support. The chuck guard acts as an effective support grip. This tool is mainly used in a standing posture, drilling on a vertical surface. The higher the feed force, the faster the rate of penetration. A typical feed force for this tool would be 150 N.

WEIGHT

As a typical material removal tool, the drill is not used in a highly repetitive motion. Tool weight is 0.7 kg and the score is 3.

TEMPERATURE

Expanded compressed air from the motor is cold. However, the full power of the tool is

rarely utilized during drilling, and the drilling cycle is usually short. Normal frequency of use lies somewhere between once every five minutes and six times per minute. The average period of use per day is assumed to be one hour. It can be assumed that the duration is 10 seconds. This results in 360 times per day or 45 times per hour. Thus, an average drilling sequence is $3,600/45 = 80$.

When the temperature at the handle is measured, the tool should run for 10 seconds at a speed equal to 75% of free running speed, a typical load when drilling, and giving 50% power, and rest for 70 seconds.

The measured temperature is 17°C, giving a score of 10.

SHOCK REACTION

A shock and its reaction happen during a short space of time. Events of less than 300 ms in duration can be considered to be shocks and, during this time, the operator can do little to influence the course of events.

A shock may occur when the drill bit penetrates a plate. Most of the feed force is

Force/Torque	MVC N/Nm	Safety factors			Reduced MVC	Real load N/Nm	Real / Reduced	Score
		Speed	Frequency	Duration				
Trigger Push forward straight arm	130 N	a1=1	a2=0.7	a3=1	91 N	15 N	0.2	2
Supination	450 N				315 N	150 N	0.5	4
	15 Nm				10 Nm	1 Nm	0.1	1
Total score:								7

Table 4.4 Evaluation of external load for the Drill LBB 26 EPX-60.

applied to the center of the drill bit in order to penetrate the material. At the point of penetration there is a dramatic fall in the amount of feed force required. An experienced operator hears when this happens and reduces the feed force accordingly. If he doesn't, the drill bit will penetrate a much thicker layer which may halt its process. The stall torque will build up rapidly, faster than 300 ms and, in principle, there will be a shock.

The stall torque for this drill is 1 Nm. Although the hand-arm system can easily cope with this torque, a skilled operator can avoid this situation. For larger drill bit sizes, it is recommended to drill a hole with a smaller bit first, thus avoiding the shock situation. The score is 0.

VIBRATION

The vibration from the machine itself is very low. During the drilling process it can be higher if the machine is used with a bent drill bit. The condition of the bit is an important factor, both for the quality of the hole and for the vibration emitted. The declared vibration value is $<2.5 \text{ m/s}^2$, the correction factor for drills is 1.5.

$$A_{(8)} = (1/8)^{1/2} \cdot 2.5 \cdot 1.5 = 1.3 \text{ m/s}^2$$

The score is 9.

NOISE

The drill has a resistive muffler in the handle containing noise diffusing material. The exhaust air can be directed away from the operator. Declared level is 80 dB(A) and the machine is used 1 hour per day.

$$L_{\text{eq}(8)} = 10 \log(1/8 \cdot 10^{8.0} \cdot 1) = 73 \text{ dB(A)}$$

The score is 0.

DUST AND OIL

The motor is lubrication free and the drilling process does not create dust. However, tests have been conducted with a flexible dust collector fitted around the drill. The purpose of these tests has been to avoid airborne carbon fibers when drilling in composite materials. These can be hazardous if they come into contact with installed electronic equipment in, for example, aircraft. The evaluation score for dust and oil is 5.

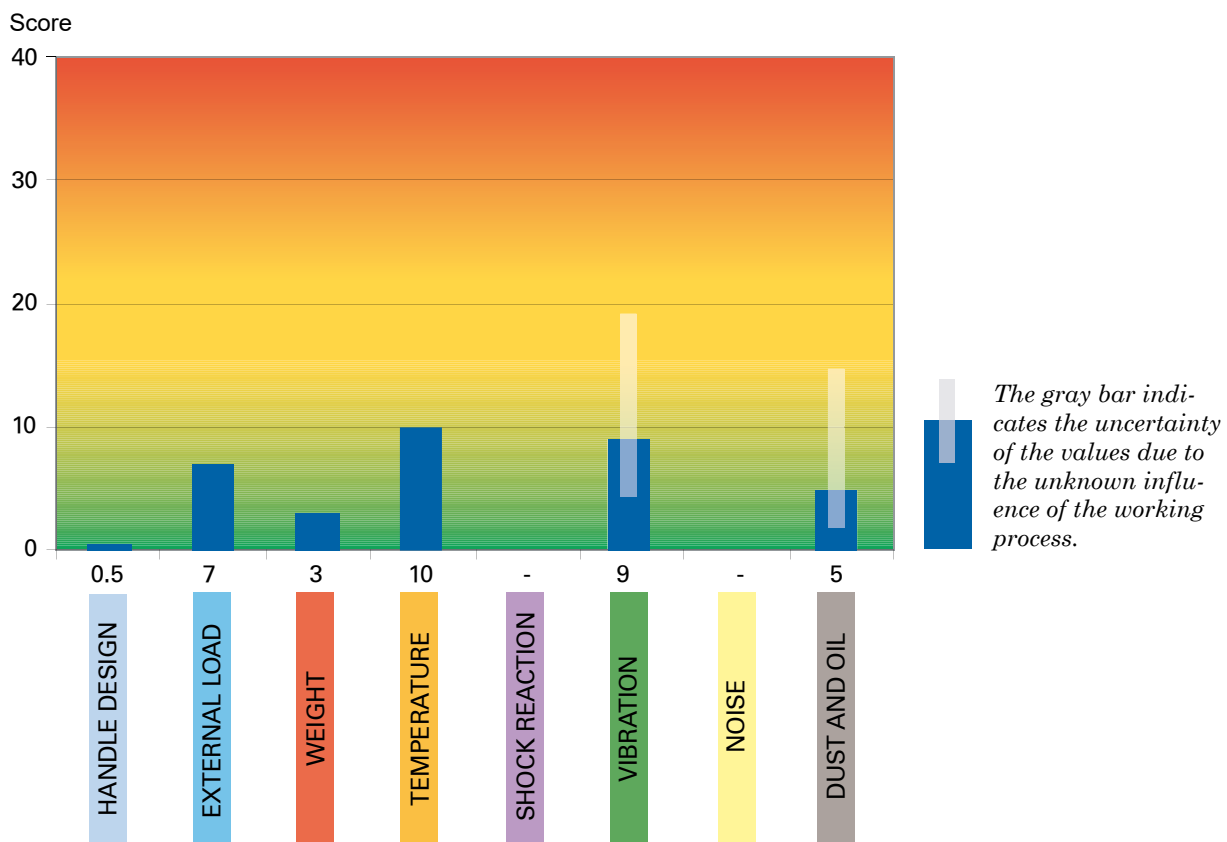

Fig. 4.2 Bar graph showing the overall result for the evaluation of the Drill LBB 26 EPX-060.

Chipping hammer

RRF 31



The relevant variables for the chipping hammer can be selected from Table 3.1 (page 71). The RRF is a vibration-controlled chipping

hammer with a blow energy of 4.4 J. It is a percussive tool mainly used by male operators to clean castings in foundries.

HANDLE DESIGN

Variables	Weighting factors (a)	Preferred (0)	Acceptable (1)	Permitted (3)	To be avoided (5)	Score
Circumference trigger activated	low force a1=1			100		3
Circumference trigger open	a2=1	140 mm				0
Length	low force a4=2	100 mm				0
End marking	a6=0.5	smooth				0
Adjustability	a7=0.5		no			0.5
Support surface	a8=0.5	yes				0
Viscoelastic coating	a9=0.5		no			0.5
Friction and ventilation	a10=0.5		painted			0.5
Total score:						4.5

Table 4.5 Evaluation of handle design for the Chipping Hammer RRF 31.

EXTERNAL LOAD

For evaluation purposes, it is assumed that the tool is being used in a cleaning operation. The chipping hammer is mainly used on horizontal surfaces and the height of the casting can be adjusted to allow a comfortable posture for the vertical push down force.

The tool is used by a male operator. It has a thumb trigger on the back of the handle that can be operated by the thumb or by the base of the thumb in the palm of the hand. In the latter case, the trigger force is part of the feed force. The force required to operate the trigger of this machine is 15 N.

The minimum feed force required for this machine is a reaction to the force resulting from the average air pressure acting on the chisel neck (otherwise the chisel would leave the machine).

The average air pressure is about 60% of the inlet pressure, generally 6.3 bar. This force is 50 N. The maximum feed force is being

applied when the spring for vibration control is bottoming, 80 N. In other words, the machine operates with low feed forces (<100 N).

WEIGHT

The weight of the tool is 2.5 kg. The score for a material removal tool is 10.

TEMPERATURE

As the inlet air passes the handle, in steady state the temperature of the handle will match that of the surrounding air temperature – in most cases room temperature.

Temperature measurements are based on a daily operator exposure of two hours or 7,200 seconds. Thus, every hour per day the tool is used equals $7,200/8 = 900$ sec. For evaluation purposes, it is assumed that the tool is operated for 10 seconds, resulting in a “10 sec. on, 30 sec. off” sequence. The machine is tested on a steel ball absorber. The temperature after steady state is 18°C, giving the score 5.

Force/Torque	MVC N/Nm	Speed	Safety factors Frequency	Duration	Reduced MVC	Real load N/Nm	Real / Reduced	Score
Trigger	100 N	a1=1	a2=0.7	a3=0.8	56 N	15 N	0.27	2.5
Push down straight arm	600 N				336 N	80 N	0.24	2
Total score:								4.5

Table 4.6 Evaluation of external load for the Chipping Hammer RRF 31.

SHOCK REACTION

There are no shock reactions when this tool is used. Thus, shock reaction does not apply for chipping hammers.

VIBRATION

The design of this tool includes an isolation system in the handle. It is a mass spring system, with a preloaded spring, the mass being the handle itself. The preloaded spring causes the isolation system to take effect from a certain minimum feed force, up to a maximum feed force when the spring is bottoming. A preloaded spring is needed because the stiffness (k factor) of the spring must be low in order to achieve a low natural frequency of the system.

The declared vibration value is 3.5 m/s^2 and the correction factor, to get an estimated vibration value for chipping hammers used in a cleaning operation, is 2. Using the daily exposure time of two hours, the estimated vibration exposure will be

$$A_{(8)} = (2/8)^{1/2} \cdot 3.5 \cdot 2 = 3.5 \text{ m/s}^2$$

This represents a score of 31.

NOISE

The measured and declared level is 94 dB(A). The continued equivalent

noise level for eight hours exposure is:

$$L_{\text{eq}(8)} = 10 \log (1/8 \cdot 10^{9.4} \cdot 2) = 88 \text{ dB(A)}$$

The score is thus 28. This value does not include process noise which can be much higher, as indicated in the diagram. The process noise is unique and depends on the characteristics of the casting being cleaned, the operator's technique and the design of the workstation.

DUST AND OIL

The chipping hammer is often used in a very dusty environment. The work involves cleaning cavities containing sand and burn deposits on the surface of the casting. A dust collector fitted to the tool interferes with the work. Therefore a well ventilated fettling booth is the best solution. The overall stressor evaluation for dust is 0-20 depending on the quality of the ventilation system.

These tools are provided with a small amount of oil. The concentration of oil mist in the breathing zone is less than 5 mg/m^3 .

From Table 3.15 a score of 4+2 can be found if the working pace is assumed to be low. The total score for dust and oil will then be 6. This score is only valid when the ventilation system at the workplace is of average quality or better.

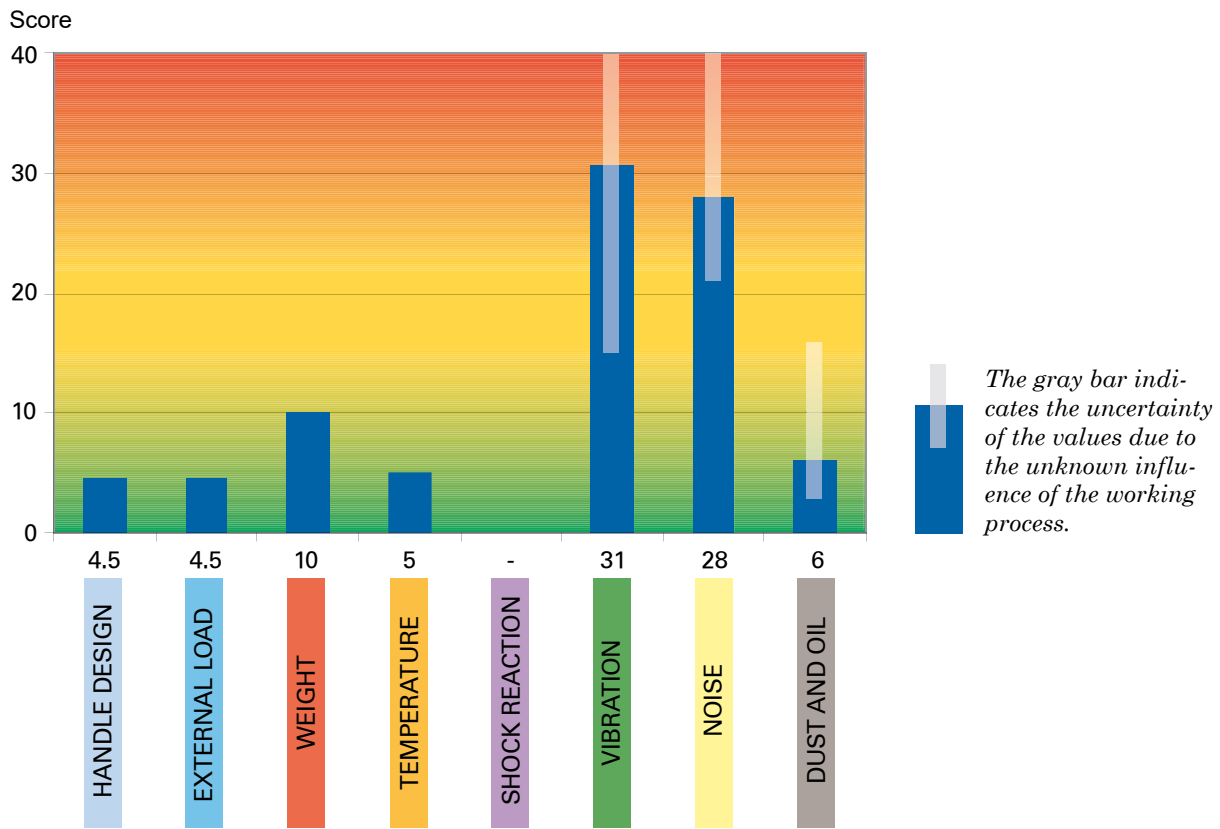

Fig. 4.3 Bar graph showing the overall result for the evaluation of the Chipping Hammer RRF 31.

Riveting hammer RRH 06



The relevant variables for the riveting hammer can be selected from Table 3.1 (page 71). This pistol riveting hammer has been designed with an active vibration damping

system. The system is capable of adapting to changes in feed forces, while retaining good vibration control properties. The tool is mainly used by male operators.

HANDLE DESIGN

Variables	Weighting factors (a)	Preferred (0)	Acceptable (1)	Permitted (3)	To be avoided (5)	Score
Circumference trigger activated	high force a1=2			150 mm		6
Circumference trigger open	a3=1			163 mm		3
Length	high force a4=2		95 mm			2
End marking	a6=0.5		no			0.5
Adjustability	a7=0.5		no			0.5
Support surface	a8=0.5	yes				0
Viscoelastic coating	a9=0.5	yes				0
Friction and ventilation	a10=0.5	good				0
Total score:						12

Table 4.7 Evaluation of handle design for the Riveting Hammer RRH 06.

EXTERNAL LOAD

For evaluation purposes, it is assumed that the tool is being used for riveting in the aircraft industry. The tool is mainly used on vertical surfaces and the height is adjusted to allow a comfortable posture for pushing the tool horizontally. The tool is used by a male operator. The damping system starts attenuating vibration at a feed force of 50 N. A feed force of up to 220 N can then be applied before bottoming occurs. The operator applies sufficient feed force to prevent the head of the rivet from jumping out of the countersinking and spoiling the panel.

The bucking bar has built-in vibration isolation, and the spring is designed to give a force of 100 N at the foot of the rivet when in use. Thus the operator must apply greater force. A trained operator applies an average force of 125 N during the riveting process.

When the tool is used with a high grip no torque is required to operate it. When

the index finger is used for triggering, together with a low grip, an ulnar flexion torque is required. This torque can be estimated as the vertical distance from the middle of the handle to the center of the tool, times the push force. In this case the distance is 70 mm and the ulnar flexion torque can be calculated as follows:

$$\begin{aligned} & \text{Ulnar flexion torque.} \\ & = 125 \text{ N} \cdot 0.07 \text{ m} = 8.75 \text{ Nm} \end{aligned}$$

When the tool is taken from the tool rest to the rivet, or moved between rivets, the weight of the tool is supported by the hand holding the trigger handle. In this case a radial flexion torque must be applied that equals the horizontal distance from the middle of the handle to the center of gravity, times the weight of the tool, times gravity.

$$\begin{aligned} & \text{Radial flexion torque} \\ & = 0.1 \cdot 1.3 \cdot 9.81 = 1.3 \text{ Nm} \end{aligned}$$

Force/Torque	MVC N/Nm	Safety factors			Reduced MVC	Real load N/Nm	Real / Reduced	Score
		Speed	Frequency	Duration				
Trigger	130 N	a1=1	a2=1	a3=1	130 N	16 N	0.12	1
Push forward straight arm	450 N				450 N	125 N	0.28	2.5
Ulnar flexion	15 Nm				15 Nm	8.75 Nm	0.58	5
Radial flexion	15 Nm				15 Nm	1.3 Nm	0.09	1
Total score:								9.5

Table 4.8 Evaluation of external load for the Riveting Hammer RRH 06.

WEIGHT

The weight is 1.3 kg, scoring 5.

TEMPERATURE

The operating cycle for this tool is less than two seconds for each rivet, and the total operation time during a working day is less than one hour. With this work cycle the tool remains at room temperature. Thus the evaluation is 1.

SHOCK REACTION

The percussion from this tool is not a single event, it is a vibration. Therefore, in that sense there is no shock reaction.

VIBRATION

This machine has been designed with an active vibration control system in the form of an isolation system utilizing an air spring and the mass of the handle. The air pressure in the air spring increases as higher feed force is applied. Thus, the very soft spring can transfer high feed forces without any significant increase in stiffness. This gives the isolation system a natural frequency well below the blow frequency it is designed to attenuate. The declared vibration value is $<2.5 \text{ m/s}^2$, and the correction factor for riveting is 1.5. The exposure time can be calculated as the number of

rivets per day, times the time it takes to set a rivet. Setting a rivet normally takes less than 2 seconds. This means that 1,800 rivets can be set per day before the exposure time exceeds 1 hour.

$$A_{(8)} = (1/8)^{1/2} \cdot 2.5 \cdot 1.5 = 1.3 \text{ m/s}^2$$

The score is thus 9.

The machine is provided with an adjustable casing to cover the die. The operator should be instructed not to touch the die or the panel during riveting. The level of vibration in the die is very high.

NOISE

The declared noise level is 91 dB(A).

$$L_{\text{eq}(8)} = 10 \cdot \log (1/8(10^{9.1} \cdot 1)) = 82 \text{ dB(A)}$$

The score is thus 12.

In the case of riveting, it is important to note that the noise from the actual process is often much higher than that shown above. The noise is generated by the motion of the panel during the blow and is of the same order as the deformation of the rivet. This is a necessary aspect of the riveting process. It is possible to attenuate the panel motion as it is transmitted along the panel. However,

this approach will only reduce one noise source and has up to now been considered impractical.

DUST AND OIL

Dust is not a stressor when riveting. The tool requires a small amount of oil in the compressed air, giving a score of 2.

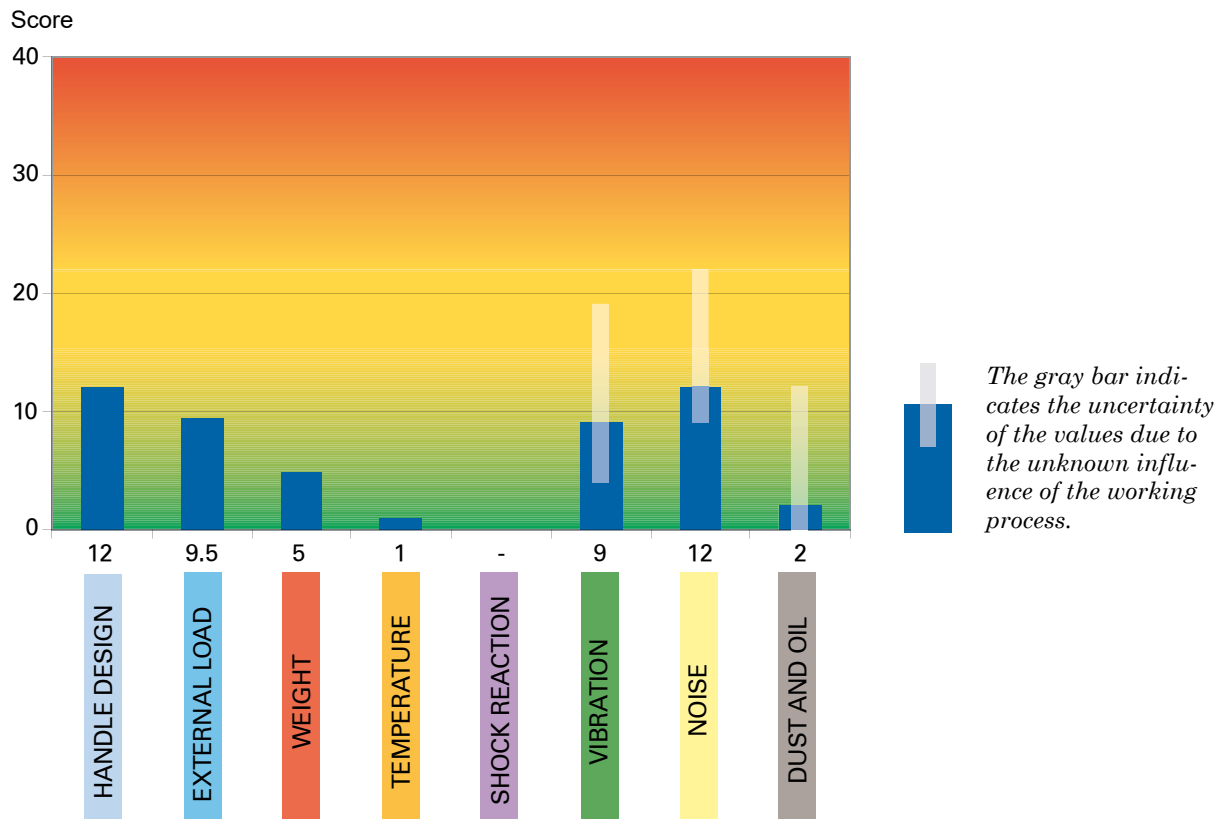

Fig. 4.4 Bar graph showing the overall result for the evaluation of the Riveting Hammer RRH 06.

Screwdriver LUM 22 PR4



The relevant variables for the screwdriver can be selected from Table 3.1 (page 71). The LUM 22 PR4 is a straight screwdriver with a torque range of 0.5-4.0 Nm. The tool

has a push-to-start function and is very often used by female operators. This evaluation is therefore based on criteria for female operators.

HANDLE DESIGN

Variables	Weighting factors (a)	Preferred (0)	Acceptable (1)	Permitted (3)	To be avoided (5)	Score
Circumference trigger activated	low force a1=1	110 mm				0
Circumference trigger open	a3=1	110 mm				0
Length	low force a4=1					0
End marking	a6=0.5	smooth				0
Adjustability	a7=0.5		no			0.5
Support surface	a8=0.5	yes				0
Viscoelastic coating	a9=0.5	yes				0
Friction and ventilation	a10=0.5	good				0
Total score:						0.5

Table 4.9 Evaluation of handle design for the Screwdriver LUM 22 PR4.

EXTERNAL LOAD

For evaluation purposes, it is assumed that the tool is operated by a female operator at a sitting workstation. The tool is supported in a balancer. The tightening torque used at this workstation is 3 Nm which is experienced as a dorsal flexion. The grip surface has good friction so the grip force will not limit the torque capacity. In most applications the push force required is low. No trigger force is experienced. The tool has a push-to-start function.

WEIGHT

Screwdrivers are often used for repetitive tasks. The dynamic motion of the tool mass is therefore important. The tool weight is 0.7 kg, giving a score of 6.

TEMPERATURE

Even if the tool is used for repetitive work, high or low temperature is not a problem. A typical tightening time is 2 seconds. In an 8-hour working day, the tool running time is usually 2 hours, resulting in a work

cycle time of 8 seconds. If the machine runs on a test joint at 4.5 Nm (range 0.5-4.5 Nm) in a “6 sec. rest, 2 sec. run” sequence, the temperature in the handle will be 17°C, giving a factor evaluation of 10.

SHOCK REACTION

The shock reaction depends on the force of the impulse entering the machine during tightening. Since this tool has a fast clutch, the impulse is primarily due to the stiffness of the joint, the torque level and power of the motor, and the inertia of the machine. The impulse from this straight machine, at 3 Nm is 2.0 Ns, giving a score of 4.

VIBRATION

The declared vibration value is <2.5 m/s². Vibration levels in these tools are low and are not normally regarded as a vibration risk. Use the declared value without any correction.

$$a_{(8)} = (2/8)^{1/2} \cdot 2.5 = 1.3 \text{ m/s}^2$$

Force/Torque	MVC N/Nm	Safety factors			Reduced MVC	Real load N/Nm	Real / Reduced	Score
		Speed	Frequency	Duration				
Dorsal flexion	10 N	a1=0.8	a2=0.6	a3=0.8	4 Nm	3 Nm	0.8	7
Total score:								7

Table 4.10 Evaluation of external load for the Screwdriver LUM 22 PR.

This gives a score of 9. In practice, the vibration value depends on the screw, the bit used and the accuracy of alignment of the machine, bit and screw during tightening.

NOISE

The declared noise level is 73, evaluation 0. From a hygienic standpoint this low level seems satisfactory. However, it is important to bear in mind that the machine is often used at a sitting assembly workstation. Here, the distance between the operator's ear and the machine may be very short, giving a higher exposure figure than the declared value.

DUST AND OIL

The machine is lubrication-free and the process does not create dust. The score is 1.

The exhaust air from the machine is piped away from the operator. This is usually appreciated, since earlier tool models were lubricated and the resulting oil mist clung to the operators' hair. The exhaust hose is still used – it does not hinder operation and noise is reduced.



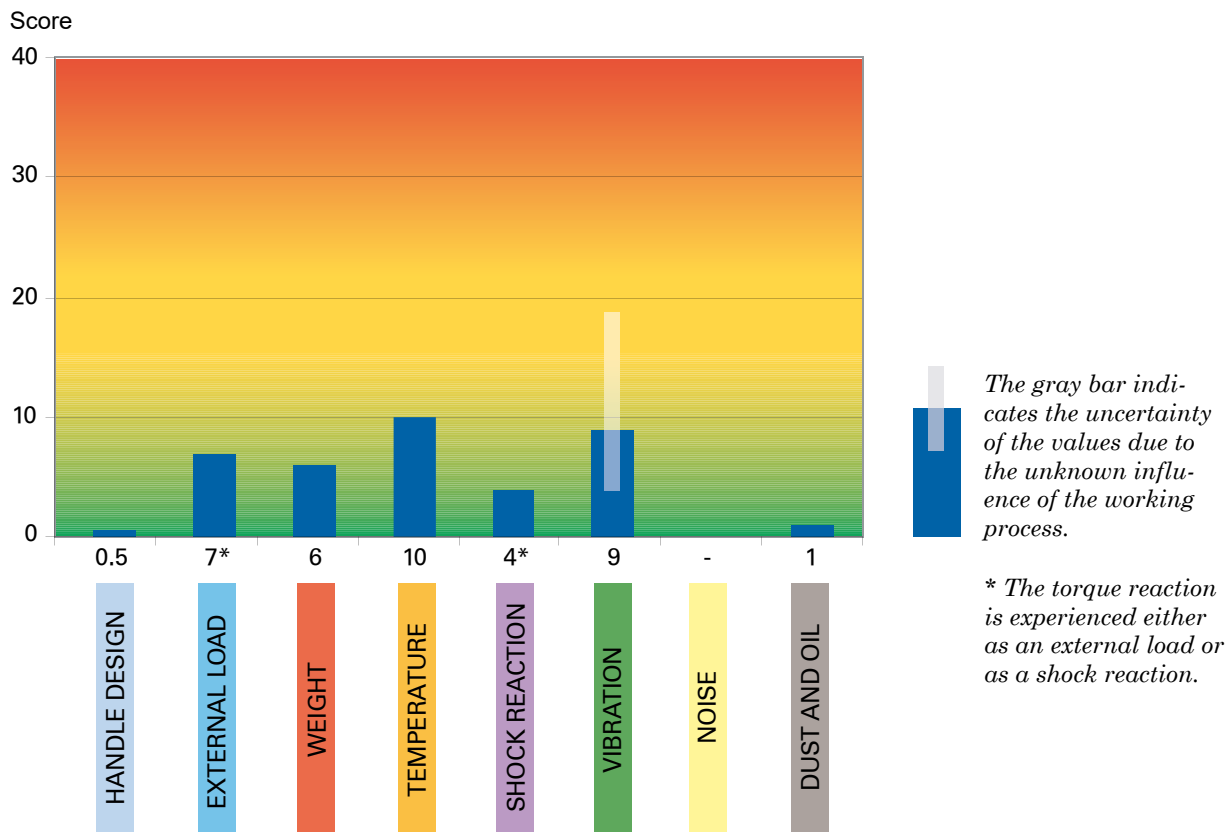

Fig. 4.5 Bar graph showing the overall result for the evaluation of the Screwdriver LUM 22 PR4.

Impulse nutrunner EP9 PTX80-HR13



The relevant variables for the pistol grip impulse nutrunner can be selected from Table 3.1 (page 71). This machine belongs to a range of nutrunners with tightening capacities from

2-350 Nm. Although there are a number of different designs, they have one common denominator – the impact from the machine into the joint is transferred via an oil cushion.

HANDLE DESIGN

Variables	Weighting factors (a)	Preferred (0)	Acceptable (1)	Permitted (3)	To be avoided (5)	Score
Circumference trigger activated	low force a1=1		138 mm			1
Circumference trigger open			155 mm			1
Length	low force a3=1		90 mm			1
End marking	a5=1	smooth				0
Adjustability	a7=0.5		no			0.5
Support surface	a8=0.5	yes				0
Viscoelastic coating	a9=0.5	yes				0
Friction and ventilation	a10=0.5	good				0
Total score:						3.5

Table 4.11 Evaluation of handle design for the Impulse Nutrunner ErgoPulse EP9 PTX80-HR13.

EXTERNAL LOAD

The tool is normally used on line assembly stations, and can be used in high torque applications without the need for torque reaction arms. The evaluation is based on a workstation where the tool is used on horizontal bolts located at chest height. The tool is operated by a male operator.

The pistol grip impulse nutrunner can be used on joints with 50-80 Nm and requires very low feed force. Torque from the motor can be estimated as maximum torque for the tool divided by 40. The tool is well balanced over the handle and torque from the center of gravity can be discounted.

WEIGHT

The impulse nutrunner is a typical assembly tool, and weighs 1.6 kg. The score is 13.

TEMPERATURE

A typical tightening cycle lasts 2 seconds. In an 8-hour working day, the average tool running time is 2 hours, resulting in a work cycle time of 8 seconds. The temperature

in the handle measured with the tool in a brake running at maximum capacity on a soft joint was 13°C, thus scoring 40.

SHOCK REACTION

Being a pulse tool, there is no shock reaction.

VIBRATION

The declared vibration value is <2.5 m/s². The recommended correction factor for pulse tools is 1.5.

$$a_{(8)} = (2/8)^{1/2} \cdot 2.5 \cdot 1.5 = 1.9 \text{ m/s}^2$$

This gives a score of 14. Assuming the typical exposure time is 2h/day. The vibration value for impulse and impact machines is directly related to how accurately the machine is aligned with the joint. When an impact is transmitted to the joint via the socket, a pair of forces acts on the joint, providing a torque. If the center line of the machine does not coincide with the center line of the joint, these forces are not synchronized and a motion tending to cause the lines to coincide will start during tightening. This is, in fact, a vibration.

Force/Torque	MVC N/Nm	Safety factors			Reduced MVC	Real load N/Nm	Real / Reduced	Score
		Speed	Frequency	Duration				
Trigger	80 N	a1=0.8	a2=0.6	a3=0.8	31 N	16 N	0.5	4
Supination	15 Nm				6 Nm	2 Nm	0.3	3
Total score:								7

Table 4.12 Evaluation of external load for the Impulse Nutrunner ErgoPulse EP9 PTX80-HR13.



Due to friction in the hydraulic pulse unit, the pulse machine has a low torque during run-down of the nut, thus lining up the machine on the joint. It is also important to note that the vibration in the socket itself is considerably higher than in the machine. It is therefore essential that the operator is informed never to hold the socket during tightening.

NOISE

The declared noise level is 83 dB(A).

$$L_{eq(8)} = 10 \cdot \log[1/8 \cdot (10^{8.3} \cdot 2)] = 74 \text{ dB(A)}$$

Thus the score is 0.

The process noise can be higher, and depends primarily on the characteristics of the joint and the structure around it. The hydraulic cushion in the pulse unit is, in fact, a low pass filter. Since the high frequencies in the blow will not enter the joint, there will be less excitation of high frequencies in the structure. This, in turn, means less process noise.

DUST AND OIL

The tool is lubrication-free and the process does not create dust, the score is 1.

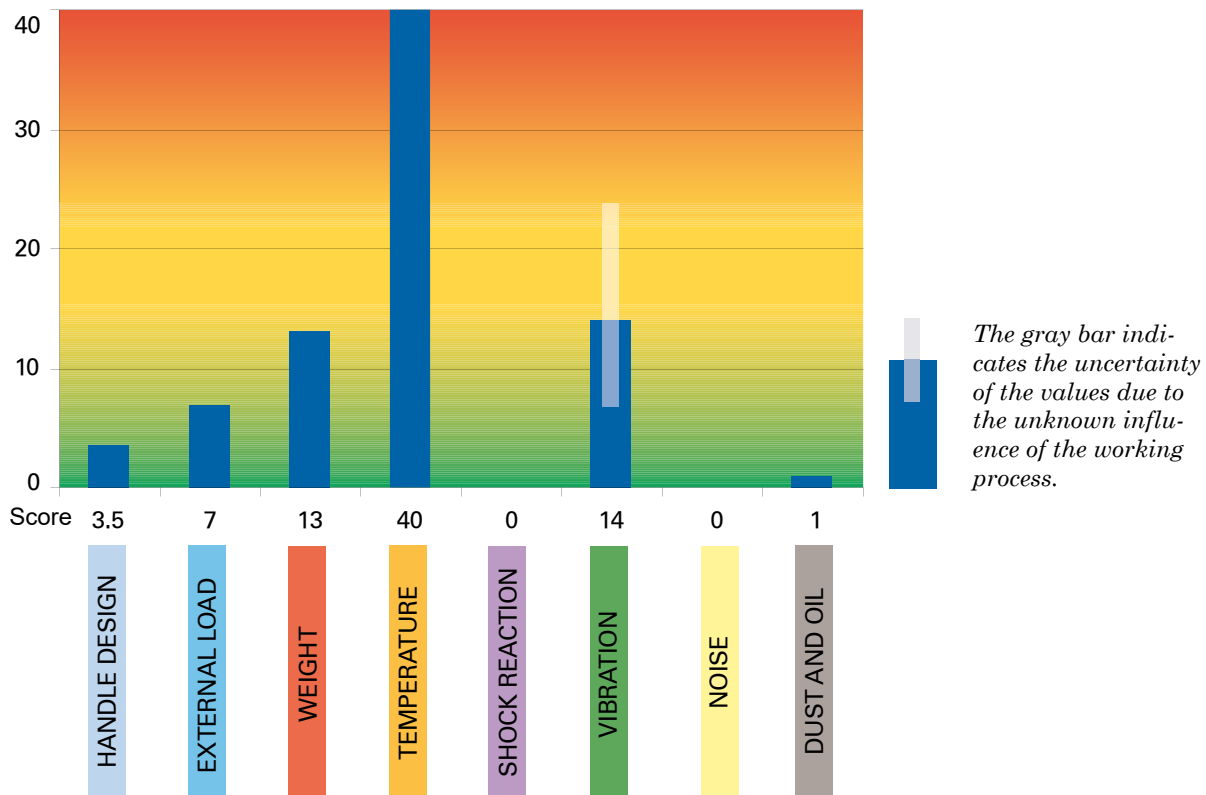

Fig. 4.6 Bar graph showing the overall result for the evaluation of the Impulse Nutrunner ErgoPulse EP9 PTX80-HR13.

Electric nutrunner ETP ST32-05-10



The relevant variables for the electric nutrunner can be selected from Table 3.1 (page 71).

The ETP ST32-05-10 electric nutrunner is controlled by a microprocessor control unit.

All parameters for the tightening process relating to different joints and operators can be fed into the control unit. The machine is suitable for both female and male operators.

HANDLE DESIGN

Variables	Weighting factors (a)	Preferred (0)	Acceptable (1)	Permitted (3)	To be avoided (5)	Score
Circumference trigger activated	low force a1=1	118 mm				0
Circumference trigger open	130					0
Length	low force a3=1	100 mm				0
End marking	a5=1	smooth				0
Adjustability	a7=0.5		no			0.5
Support surface	a8=0.5	yes				0
Viscoelastic coating	a9=0.5		no			0.5
Friction and ventilation	a10=0.5	good				0
Total score:						1

Table 4.13 Evaluation of handle design for the Electric Nutrunner ETP ST32-05-10.

EXTERNAL LOAD

This tool is typically used on assembly lines in the vehicle and white goods industries by both male and female operators. The operations are often highly repetitive and performed at a fast pace.

The evaluation of this tool is based on a standing assembly workstation, adjusted to provide a comfortable working height. The evaluation is made separately for male and for female operators. It is assumed that the torque is set to 4 Nm. Furthermore, the joint is assumed to be soft, therefore the reaction torque must be handled by the operator.

The torque range for this tool is 1-5 Nm. For soft joints we recommend maximum torque settings of 5 Nm and 4 Nm, respectively, for male and female operators at workstations where the tasks are highly repetitive.

However, the full torque of range for these tools can be utilized safely if the tool is fitted with a support handle, or used with a torque reaction arm. For hard joints, the control system can be programmed to minimize the impulse and the operator does not need to supply the full reaction torque. On hard joints of this type a higher torque can be accepted before a torque reaction arm is required. Real loads can be calculated as follows:

- Trigger force is measured to 9 N,
- On soft joints the installed torque will give a reaction torque (supination) that equals the installed torque. In this case 4 Nm.
- The tool handle is designed to reduce radial flexion torque caused by the distance from the handle to the center of gravity.

Male operators

Force/Torque	MVC N/Nm	Safety factors			Reduced MVC	Real load N/Nm	Real / Reduced	Score
		Speed	Frequency	Duration				
Trigger	80 N	a1=0.8	a2=0.6	a3=0.8	31 N	9 N	0.3	3
Supination	15 Nm				6 Nm	4 Nm	0.7	6
Total score:								9

Female operators

Force/Torque	MVC N/Nm	Safety factors			Reduced MVC	Real load N/Nm	Real / Reduced	Score
		Speed	Frequency	Duration				
Trigger	50 N	a1=0.8	a2=0.6	a3=0.8	19 N	9 N	0.5	4
Supination	10 Nm				4 Nm	4 Nm	1	20
Total score:								24

Table 4.14 Evaluation of external load for the Electric Nutrunner ETP ST32-05-10.

WEIGHT

The electric nutrunner is a typical assembly tool, and weighs 0.8 kg. Thus, the score is 6.

TEMPERATURE

A typical tightening cycle lasts 2 seconds. In an 8-hour working day, the average tool running time is normally 2 hours, resulting in a work cycle time of 8 seconds. The temperature in the handle, measured with the tool in a brake running at maximum capacity on a soft joint, was 27°C, thus scoring 2.

SHOCK REACTION

Electrically powered tools open up a new dimension in the struggle to prevent sudden forces being transmitted into the hand-arm system during tool operation.

A microprocessor is used to control and monitor the tightening operation. Its possibilities are described under Evaluation of Electric Angle Nutrunner Tensor ST61. The system offers a high degree of flexibility in terms of individual parameter settings that will get the best subjective response from the operator.

VIBRATION

If power sockets are of good quality and the tool is held in line with the joint, low vibrations are guaranteed. The declared value is

<2.5 m/s². If we assume the same daily duration as for impulse nutrunners (2 hours), the 8-hour exposure will be

$$a_{(8)} = (2/8)^{1/2} \cdot 2.5 = 1.3 \text{ m/s}^2$$

Also in this case it is recommended to use 2.5 without any correction. The score is thus 6.

NOISE

The declared noise level is <70 dB(A) and there is no process noise, thus the score is 0.

DUST AND OIL

The tool is lubrication-free and the process does not create dust. Score 1.

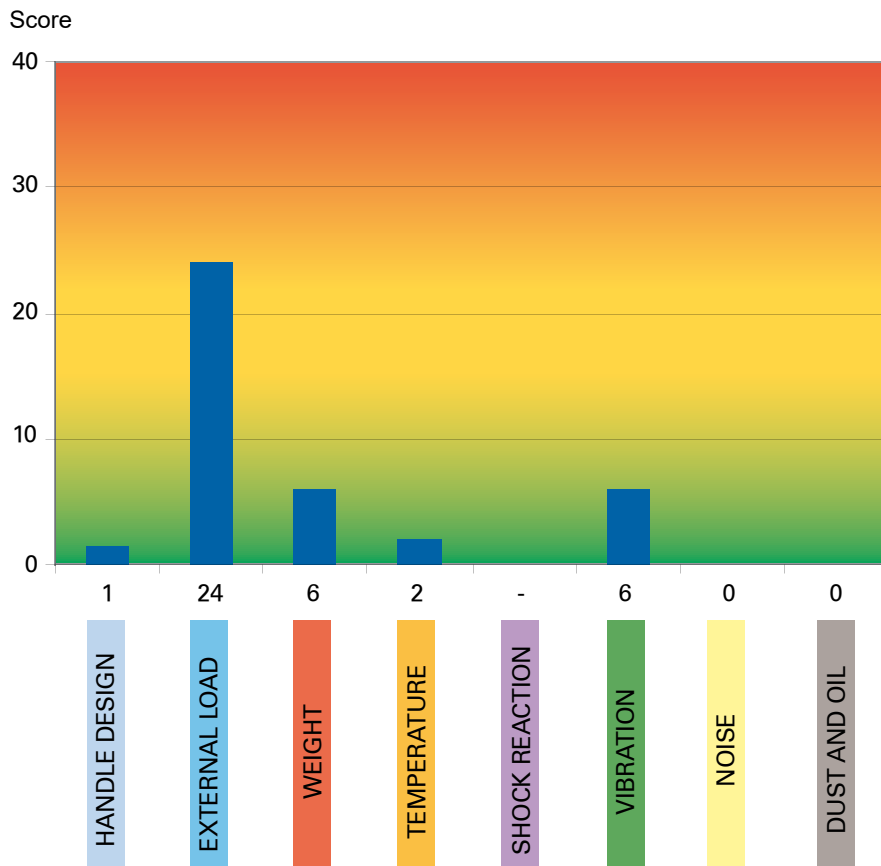

Fig. 4.7 Bar graph showing the overall result for the evaluation of the Electric Nutrunner ETP ST32-05-10 used by a female operator.

Angle nutrunner LTV 29 R30-10



The relevant variables for the angle nutrunner can be selected from Table 3.1 (page 71). The LTV 29 R30-10 is an angle nutrunner with a torque capacity of 14-28 Nm. It is equipped with a very fast mechanical

clutch, giving a low level of shock reaction. The machine is suitable for both female and male operators.

The evaluation of handle design is based on criteria for a male operator.

HANDLE DESIGN

Variables	Weighting factors (a)	Preferred (0)	Acceptable (1)	Permitted (3)	To be avoided (5)	Score
Circumference trigger activated	low force a1=1	130 mm				0
Circumference trigger open		170 mm				0
Length	low force a3=1	100 mm				0
End marking	a5=1	smooth				0
Adjustability	a7=0.5		no			0.5
Support surface	a8=0.5	yes				0
Viscoelastic coating	a9=0.5	yes				0
Friction and ventilation	a10=0.5	good				0
Total score:						0.5

Table 4.15 Evaluation of handle design for Angle Nutrunner LTV 29 R30-10.

EXTERNAL LOAD

For evaluation purposes, it is assumed that the tool is being used for line assembly in the car industry at a workstation where it is used on horizontal surfaces. The installed torque is assumed to be 28 Nm. The height is adjusted to allow a comfortable posture for counteracting the horizontal pull force from the torque reaction. The tool is not suspended in a balancer. It is picked up from the tool rest with one hand, resulting in a radial flexion torque. It is also operated with one hand when tightening. Thus a

palmar flexion torque will load the operator during tightening. When the tool is positioned on the bolt head a supination torque is required to hold the tool as it enters the bolt.

It is assumed that both male and female operators use the workstation. Therefore two evaluations of external load are made, one for male operators and one for female operators. Real loads can be calculated as follows:

- Trigger force is measured to 4 N with the air inlet connected,
- On soft joints the installed torque will give a reaction force (pull back) on the

Male operators

Force/Torque	MVC N/Nm	Safety factors			Reduced MVC	Real load N/Nm	Real / Reduced	Score
		Speed	Frequency	Duration				
Trigger	380 N	a1=0.8	a2=0.6	a3=0.8	148N	4 N	0.03	0
Pull back	400 N				154 N	104 N	0.7	6
Palmar flexion	15 Nm				6 Nm	3.1 Nm	0.5	4
Radial flexion	15 Nm				6 Nm	1.4 Nm	0.2	2
Supination	15 Nm				6 Nm	1.4 Nm	0.2	2
Total score:								14

Female operators

Force/Torque	MVC N/Nm	Safety factors			Reduced MVC	Real load N/Nm	Real / Reduced	Score
		Speed	Frequency	Duration				
Trigger	245 N	a1=0.8	a2=0.6	a3=0.8	92N	4 N	0.04	0
Pull back	300 N				131 N	104 N	0.9	14
Palmar flexion	10 Nm				4 Nm	3.1 Nm	0.8	7
Radial flexion	10 Nm				4 Nm	1.4 Nm	0.4	4
Supination	10 Nm				4 Nm	1.4 Nm	0.4	4
Total score:								29

Table 4.16 Evaluation of external load for the Angle Nutrunner LTV29 R30-10. Evaluations are given for both male and female operators.

operator equal to installed torque divided by the distance from the spindle to the center of the handle. In this case:
 $28/0.270 = 104 \text{ N}$

- Palmar flexion torque during tightening equals the pull force (104 N) multiplied by the height of the angle head above the bolt head. In this case: $104 \text{ N} \cdot 0.03 \text{ m} = 3.1 \text{ Nm}$
- Supination torque when entering the bolt is the distance from mid-handle to center of gravity, times weight, times gravity. In this case: $0.1 \text{ m} \cdot 1.45 \text{ kg} \cdot 9.81 = 1.4 \text{ Nm}$
- When the tool is picked up from the tool rest the radial flexion torque can be calculated in the same way as the supination torque.

WEIGHT

The angle nutrunner is a typical assembly tool, and weighs 1.4 kg. Thus, the score is 11.

TEMPERATURE

A typical tightening cycle lasts 2 seconds. In an 8-hour working day, the average tool running time is normally 2 hours, resulting in a work cycle time of 8 seconds. The temperature in the handle, measured with the tool in a brake running at maximum capacity on a soft joint, was 15°C, thus scoring 4.

SHOCK REACTION

The shock reaction from an angle nutrunner depends to a large extent on the joint, i.e., whether it is a hard or a soft joint, or some-

where in between. It also depends on the operator's posture, whether the operator's hand-arm is in line with the motion of the handle, or perpendicular to the motion.

All these factors influence the magnitude of the impulse from the joint reaction that tries to rotate the tool.

For the purposes of evaluation we use a torque setting of 28 Nm. The impulse is estimated to 2.0 Ns, resulting in a score of 2.

This is not taken into account in the evaluation since we based it on a soft joint and the torque reaction is evaluated as a load on the operator.

VIBRATION

During the development of the vibration test codes for declaration purposes it was found that, in all tests, angle nutrunners had vibration values below 2.5 m/s². The Machine Directive stipulates that if the vibration value is below 2.5 m/s², this fact should be stated. In other words the manufacturer is not obliged to give the actual value. The Standards Committee decided not to develop a test code for angle nutrunners. The manufacturer must, however, be sure that the value is less than 2.5 m/s². To estimate vibration during use, here again it is recommended not to use any correction.

$$a_{(8)} = (2/8)^{1/2} \cdot 2.5 = 1.3 \text{ m/s}^2$$

The score is thus 9.

NOISE

The declared noise level is 77 dB(A).

$$L_{eq(8)} = 10 \log (1/8 \cdot 10^{7.7} \cdot 2) = 71 \text{ dB(A)}$$

The score is 0.

DUST AND OIL

The tool is lubrication-free and the process does not create dust. The score is 1.

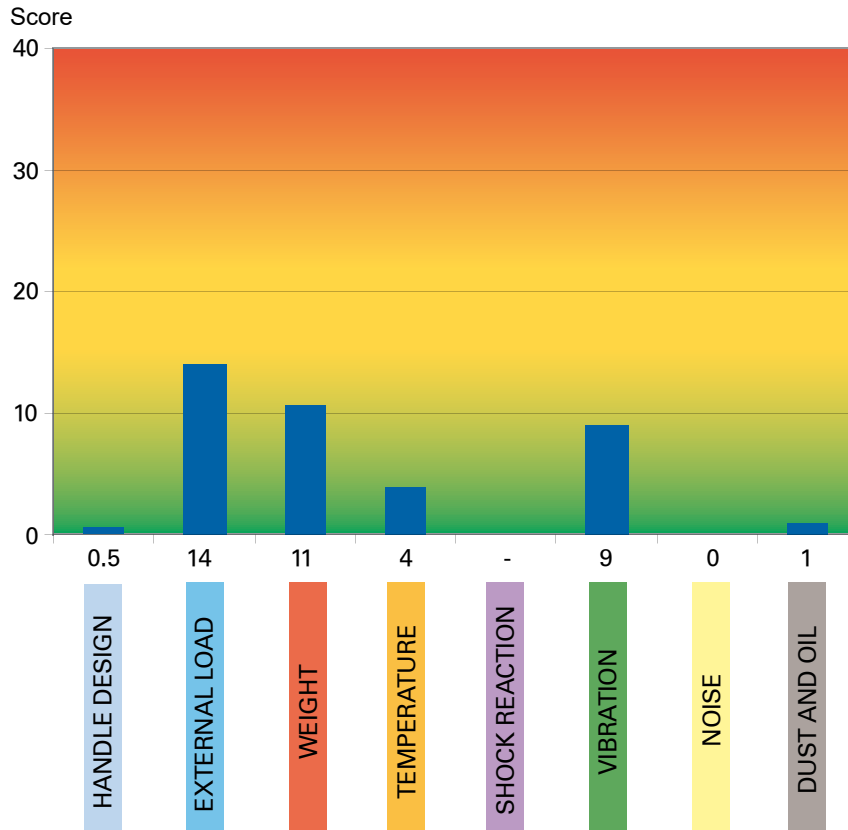

Fig. 4.8 Bar graph showing the overall result for the evaluation of the Angle Nutrunner LTV29 R30-10 when used by a male operator.

Electric angle nutrunner

Tensor ST61-50-10



The relevant variables for the electric angle nutrunner can be selected from Table 3.1 (page 71). The Tensor ST61-50-10 is an electric angle nutrunner for a torque range of 10-55 Nm. It is controlled and monitored

by a microprocessor. All parameters for the tightening process relating to different joints and operators can be fed into the system. The tool is suitable for both female and male operators.

HANDLE DESIGN

Variables	Weighting factors (a)	Preferred (0)	Acceptable (1)	Permitted (3)	To be avoided (5)	Score
Circumference trigger activated	low force a1=1	115 mm				0
Circumference trigger open	120mm					0
Length	low force a3=1		95 mm			1
End marking	a5=1	smooth				0
Adjustability	a7=0.5		no			0.5
Support surface	a8=0.5	yes				0
Viscoelastic coating	a9=0.5		no			0.5
Friction and ventilation	a10=0.5	good				0
Total score:						2

Table 4.17 Evaluation of handle design for Electric Angle Nutrunner Tensor ST61-50-10.

EXTERNAL LOAD

For evaluation purposes, it is assumed that the tool is being used for line assembly in the motor vehicle industry at a workstation where the tool is used on horizontal surfaces. The height is adjusted to allow a comfortable posture for counteracting the horizontal pull force from the torque reaction. The tool is used on a 50 Nm soft joint. It is operated with two hands. The tool is suspended in a balancer. The balancer is assumed to be correctly adjusted, therefore the pulldown force can be discounted.

It is assumed that both male and female operators use the workstation. Therefore two evaluations of external load have been

made, one for male operators and one for female operators. Two-handed operation means there will be no palmar flexion torque. Since the tool is suspended in a balancer, supination and radial flexion torque can be discounted.

Real loads can be calculated as follows:

- Trigger force is measured to 3 N. The trigger can be operated using one or two fingers.
- On soft joints the installed torque will give a reaction force (pull back) on the operator equal to the installed torque divided by the distance from the spindle to the center of the handle. In this case: $50/0.370 = 135 \text{ N}$.

Male operators

Force/Torque	MVC N/Nm	Safety factors			Reduced MVC	Real load N/Nm	Real / Reduced	Score
		Speed	Frequency	Duration				
Trigger	80 N	a1=0.8	a2=0.6	a3=0.8	31 N	3 N	0.1	1
Pull back	400 N				154 N	135 N	0.9	14
Total score:								15

Female operators

Force/Torque	MVC N/Nm	Safety factors			Reduced MVC	Real load N/Nm	Real / Reduced	Score
		Speed	Frequency	Duration				
Trigger	50 N	a1=0.8	a2=0.6	a3=0.8	19 N	3 N	0.2	2
Pull back	300 N				115 N	135 N	1.2	33
Total score:								35

Table 4.18 Evaluation of external load for the Electric Angle Nutrunner Tensor ST61-50-10. Evaluations are given for both male and female operators.

WEIGHT

The electric nutrunner is a typical assembly tool, and it weighs 1.5 kg. Thus, the score is 12.

TEMPERATURE

A typical tightening cycle lasts 2 seconds. In an 8-hour working day, the average tool running time is normally 2 hours, resulting in a work-cycle time of 8 seconds.

The temperature in the handle, measured with the tool running on a soft joint with the maximum torque setting, is 40°C, thus scoring 13.

SHOCK REACTION

This electric tool presents two options regarding shock reaction. The joint itself influences the choice.

If the joint is a hard joint, the Power Focus can be programmed for a minimum tightening time. This gives a low impulse into the machine, resulting in a very low shock reaction. A medium-soft joint can be tightened in a double sequence, starting with a pre-tightening sequence up to a torque that is lower than the final torque. The pre-torque is calculated to get an acceptable impulse. Final tightening then takes place at low speed, with the speed gradually increasing to pre-set final torque

and then gradually decreasing to zero. Final tightening takes longer than 300 ms and is not regarded as a shock. For very soft joints, tightening can be carried out in one sequence, with a smooth ramp up and down.

The parameters can be set in a way that achieves the best subjective response from the operator. Different parameter settings for different operators can be stored in Power Focus, and each operator starts the shift by entering a personal code.

For a hard joint at a presetting of 50 Nm, the impulse is 4 Ns and the score is 4.

VIBRATION

The declared vibration value is <2.5 m/s². Assuming the duration of exposure is 2 hours per day, and when using the same discussion as for LTV, the result will be:

$$a_{(8)} = (2/8)^{1/2} \cdot 2.5 = 1.3 \text{ m/s}^2$$

The score is 9.

NOISE

The declared noise level is below 70 dB(A) and the score is 0.

DUST AND OIL

The tool is lubrication-free and does not create dust. The score is 0.

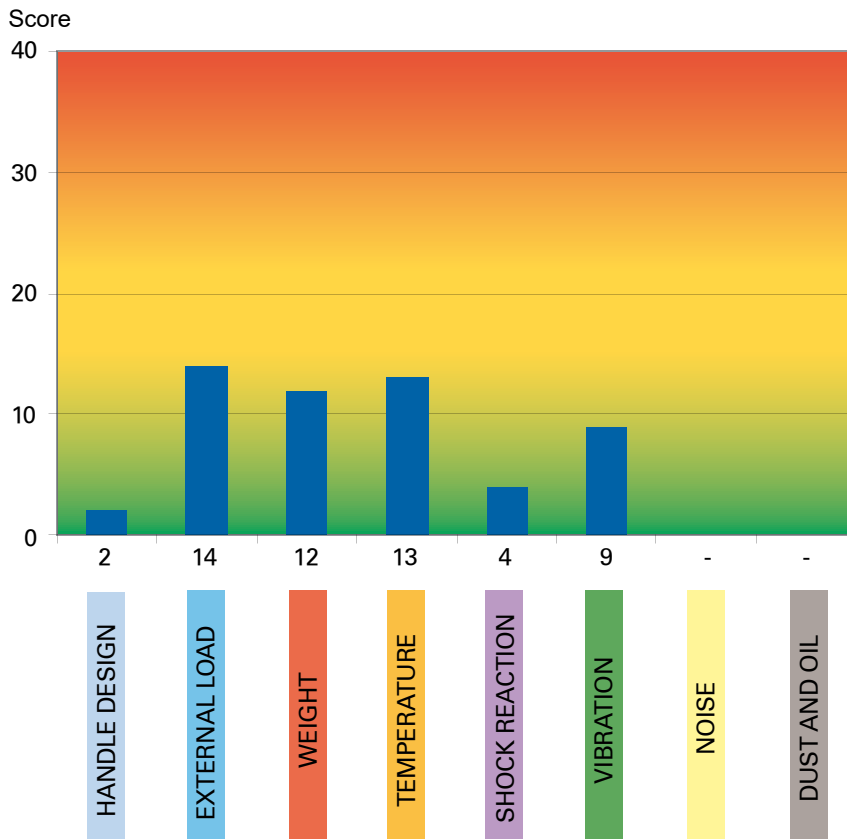

Fig. 4.9 Bar graph showing the overall result for the evaluation of the Angle Nutrunner Tensor ST61-50-10 when used by a male operator.

High torque nutrunner LTP 51



The relevant variables for this high torque nutrunner can be selected from Table 3.1 (page 71).

The torque range of this nutrunner is

130-1,000 Nm. It is always operated with a reaction bar. The tool is used mainly by male operators in the heavy vehicle segment of the automotive industry.

HANDLE DESIGN

Variables	Weighting factors (a)	Preferred (0)	Acceptable (1)	Permitted (3)	To be avoided (5)	Score
Circumference trigger activated	low force a1=1			152 mm		3
Circumference trigger open				165 mm		3
Length	low force a3=1	105 mm				0
End marking	a5=1	smooth				0
Adjustability	a7=0.5		no			0.5
Support surface	a8=0.5	yes				0
Viscoelastic coating	a9=0.5	yes				0
Friction and ventilation	a10=0.5	good				0
Total score:						6.5

Table 4.19 Evaluation of handle design for the High Torque Nutrunner LTP 51.

EXTERNAL LOAD

When working with this tool external loads are small. No feed force is required and there is no wrist torque. Since the machine is a stall-torque tool for high torque levels and is always used with a reaction bar, there are no external loads from the process.

WEIGHT

The important factor is weight. A tool designed for torques of 1,000 N and above will be heavy. Evaluating this tool in terms of weight is a delicate task. It can be equipped with different gear trains to produce different torques, and the weight can vary between 2.9 kg and 5.6 kg.

As this tool is never used in intensive applications, the score is in the range of 10-20. Only the lightest tools are hand-held in operation. The majority of tools are suspended in balancers. In this evaluation we award the tool a score of 12.

TEMPERATURE

Cold air from the vane motor and heat emitted by the gear train will balance each other out quite effectively in a typical work situation.

The temperature of the tool will thus be around room temperature, giving a score of 1.

SHOCK REACTION

The use of a reaction bar ensures that there will be no shock reaction, 0.

VIBRATION

The declared vibration value is $<2.5 \text{ m/s}^2$. The total duration of use per day is one hour.

$$a_{(8)} = (1/8)^{1/2} \cdot 2.5 = 0.9 \text{ m/s}^2$$

This gives a score of 6.

Force/Torque	MVC N/Nm	Speed	Safety factors Frequency	Duration	Reduced MVC	Real load N/Nm	Real / Reduced	Score
Trigger	80 N	a1=1	a2=1	a3=1	80N	24 N	0.3	3
Total score:								3

Table 4.20 Evaluation of external load for the High Torque Nutrunner LTP 51. Evaluations are given for both male and female operators.

NOISE

The declared noise level is 79 dB(A). Daily exposure is one hour.

$$L_{eq(8)} = 10 \log (1/8 \cdot 10^{7.9} \cdot 1) = 70 \text{ dB(A)}$$

Thus, the score is 0.

DUST AND OIL

No dust is created by the tool or by the process. The tool uses oil for lubrication. However, taking into consideration the way the tool is used, it is very unlikely that it will expose the operator to airborne oil in excess of 5 mg/m³ in the breathing zone. The score is 4 according to Table 3.15 on page 132.

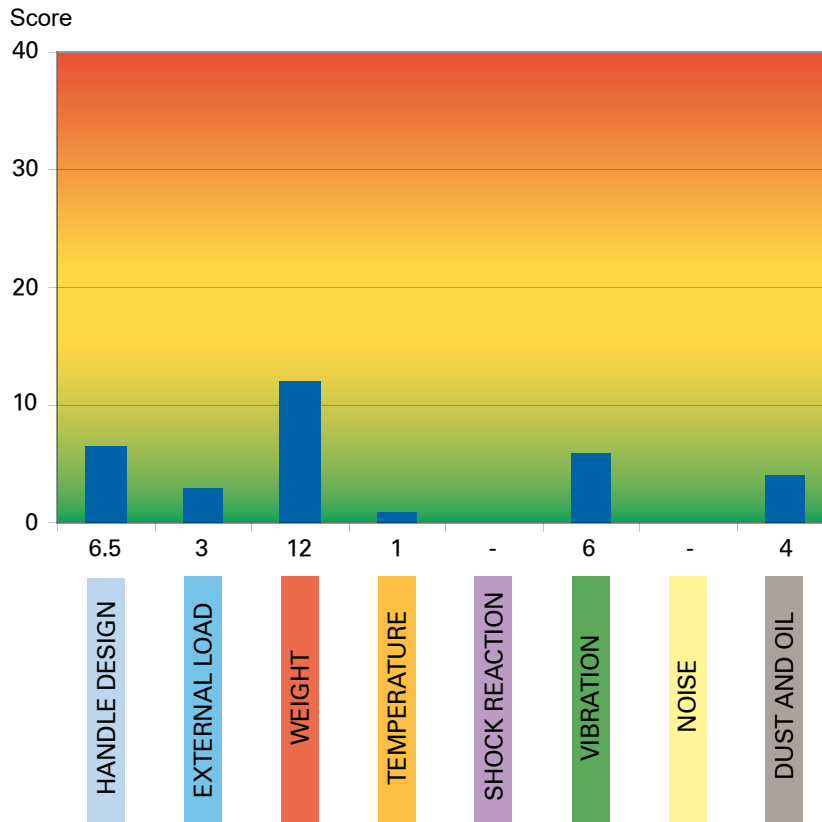

Fig. 4.10 Bar graph showing the overall result for the evaluation of the High Torque Nutrunner LTP 51.

When you select a hand-held power tool, you not only influence the task the tool is intended to perform, but also the operator's work situation and the entire working environment. Combined, these factors have a major influence on operator health, safety and productivity. Based on 40 years of research, testing and experience, this book examines the interaction between these factors.

Committed to your superior productivity

Atlas Copco