

# *E-Swirl 2 AdX BIW*

Flexible application with long-term  
quality assurance

*Atlas Copco*



# *Freedom in design – flexible in the process*

*For excellent material distribution and bonding that stands the test of time – you need a solution that can handle various applications with consistent precision.*

If you are aiming for an advanced automated system with additional functionalities and accessories for increased quality, you need to be looking at the E-Swirl 2 AdX BIW paired with a common SCA system controller. The Swirl technology offers a more reliable process window giving you control and avoiding common difficulties with bonding in Body in White.

## **E-Swirl 2 AdX BIW eliminates the most common pains**

Hem flange joints are among the most challenging joining processes in Body in White. And advanced car designs even increase the demand for a flexible bonding application. The E-Swirl pattern ensures an optimal material distribution that eliminates the most common pains such as corrosion and material waste.

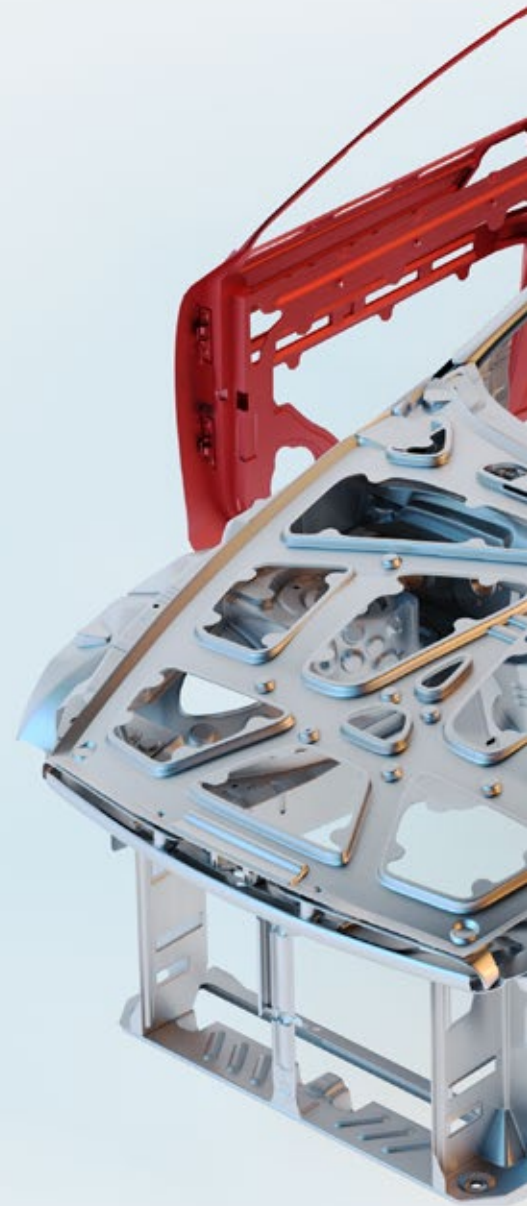

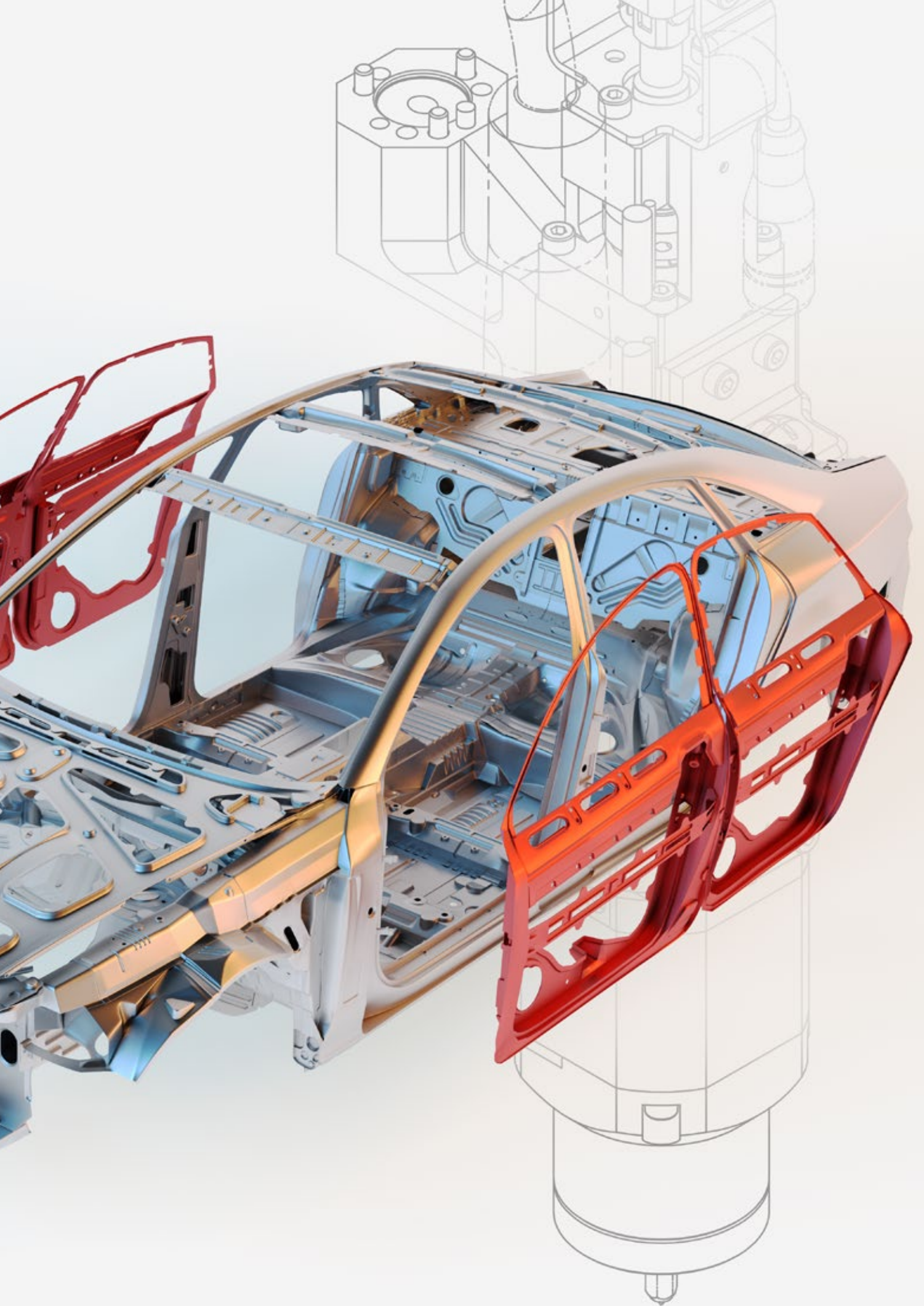



# E-Swirl 2 AdX BIW

## *Giving you a competitive edge*

The E-Swirl 2 AdX BIW offers optimal material distribution and a clean application with sharply contoured edges. Just what the industry needs to increase the competitive edge in terms of long-term quality guarantee and a significant reduction of reworks. With this tool you have one product for various applications: both swirl and bead. Giving you an optimal application through changes of width and constrictions that perfectly fit the geometry of the individual component/part.



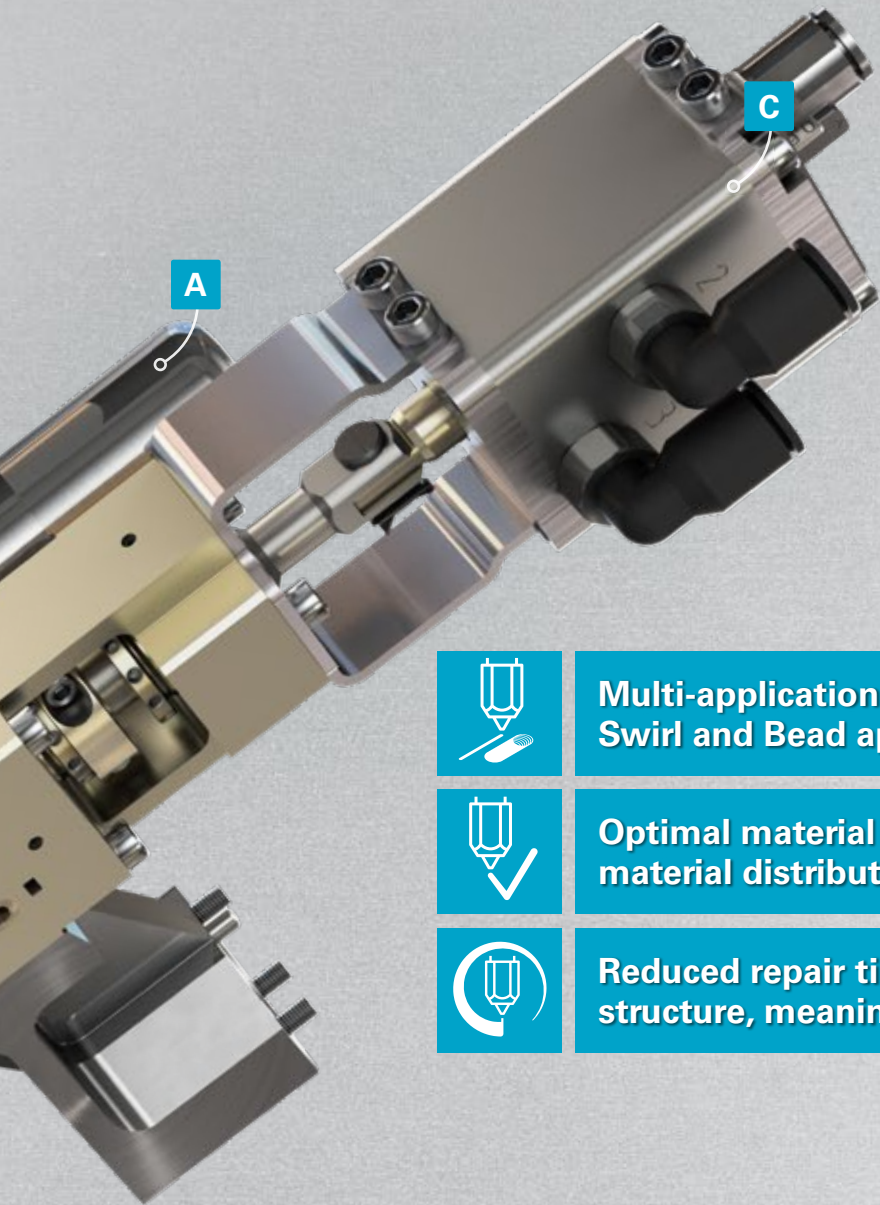

**Multi-applications means one applicator for Swirl and Bead applications**



**Optimal material dispense with excellent material distribution**



**Reduced repair time with a standardized part structure, meaning flexible repairs**

## Features

- A** Connection for electric drive that drives excenter
- B** Close to constant temperature reached by radiant heat
- C** Pneumatic excenter drive, enables different positions for achieving the adjusted excenter position
- D** Optimized nozzle geometry for clean application
- E** One applicator for Swirl and Bead applications thanks to adjustable excenter



# No squeeze out, no rework

*The E-Swirl 2 AdX BIW is answering to the demand for a solution that can dispense the bonding material to efficiently fill the hollow space between hemmed metal parts.*

With the material distribution of the E-Swirl 2 AdX BIW you have just the right bead width and filling rate. It also addresses different issues with the material such as viscosity and temperatures, to name a few.

## **Insufficient gap filling leads to boil out**

These panels have insufficient material distribution causing material squeeze out and air gaps that will lead to boil out. Gap problems account for the most significant amount of rework in the manufacturing process. And overspill is waste that accumulates over time.

## **Completely filled gap**

These panels are joined together with an improved material distribution, giving you a high quality and corrosion free bonding with just the right amount of material applied.



**A sound and long lasting investment.**

Make full use of your IAS investment with our wide range of service offers. Global 24/7 programs that make the most of your investment.

Contact us at  
[ias.service-solutions@atlascopco.com](mailto:ias.service-solutions@atlascopco.com)

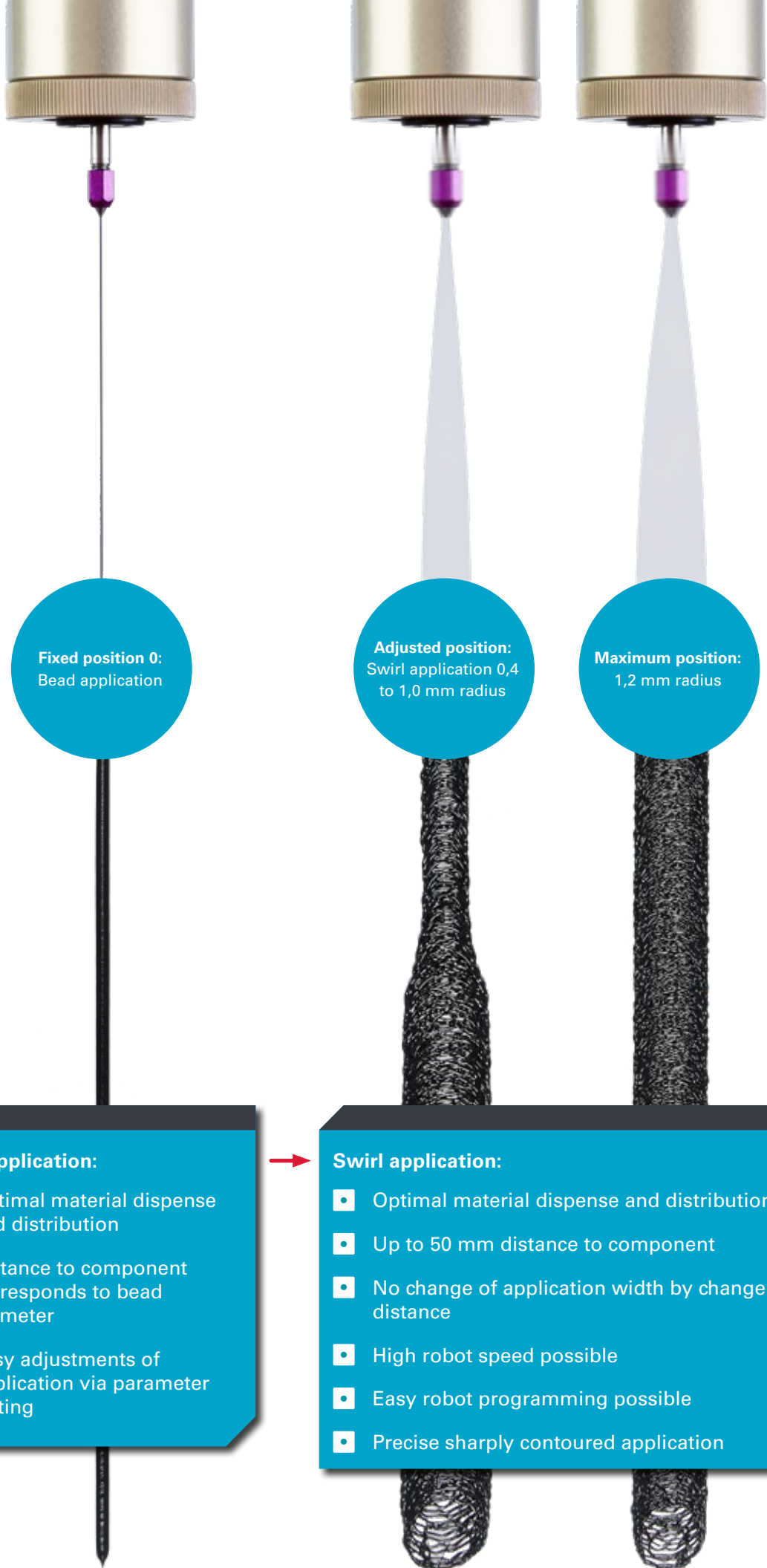

**Fixed position 0:**  
Bead application

**Adjusted position:**  
Swirl application 0,4  
to 1,0 mm radius

**Maximum position:**  
1,2 mm radius

Multiple setup  
options to fit your  
exact needs

- Bead application:**
- Optimal material dispense and distribution
  - Distance to component corresponds to bead diameter
  - Easy adjustments of application via parameter setting

- Swirl application:**
- Optimal material dispense and distribution
  - Up to 50 mm distance to component
  - No change of application width by change of distance
  - High robot speed possible
  - Easy robot programming possible
  - Precise sharply contoured application

## E-Swirl 2 AdX BIW Specifications and ordering number

Model	Weight		Length mm	Max working temp.		Electric drive (rpm)	Pneumatic drive (bar)	Ordering no.
	kg	lb		°C	°F			
E-Swirl 2 AdX BIW	3.20	7.05	279.2	60	140	Up to 24 000	4-5	84411.000164

### Additional Equipment

Model	Ordering no.
Swirl-box for SYS 6000 connection	90421.821013
Pins for excenter adjustment from 0.4 to 1.0 mm	80658.000210
Nozzles PVC On request: diameter from 0.25 to 1.4 mm	0681.123804
Nozzles Epoxy On request: diameter from 0.4 to 1.0 mm	80681.064106

### Commissioning and Spare parts

Model	Ordering no.
Programming aid	89011.100397
Electric drive incl. excenter	80450.000082
Pneumatic excenter drive	80619.000084
Seal kit material contact	80319.000556
Seal kit pneumatic drive	80319.000557

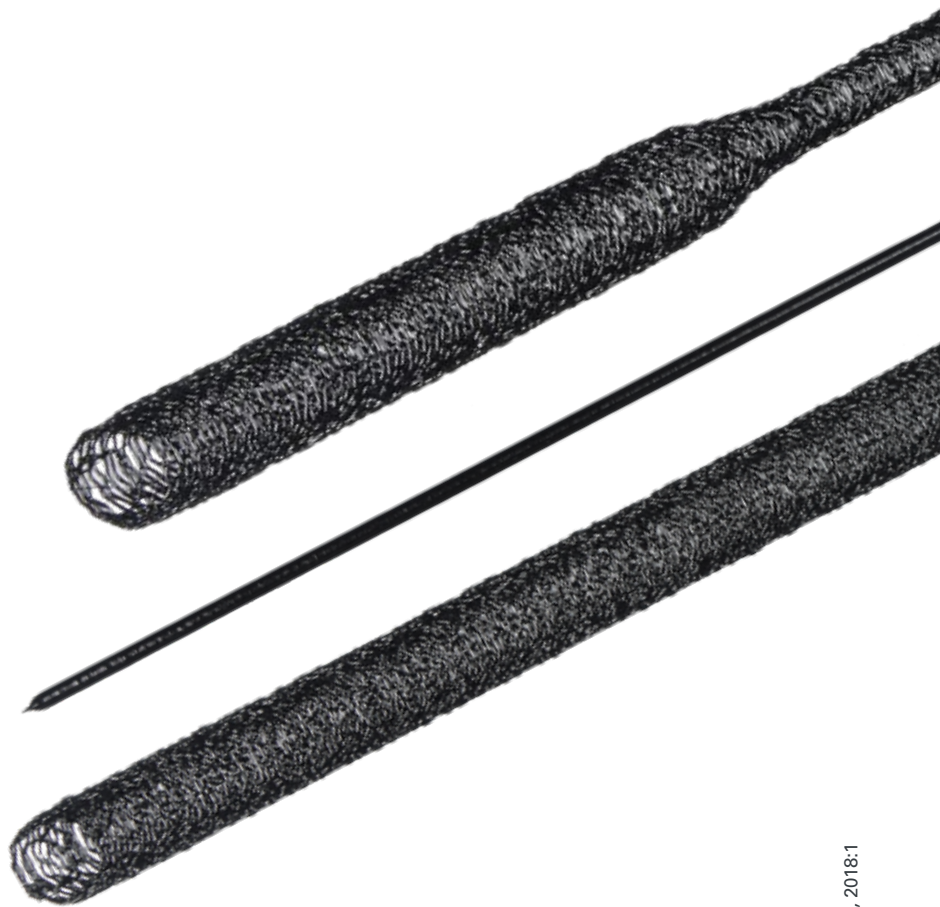

*Committed to sustainable productivity*

[www.atlascopco.com](http://www.atlascopco.com)

*Atlas Copco*