

SAFETY INSTRUCTIONS



Truck

To determine whether a truck is suited for transport of the unit:

- compare the dimensions of the unit with the truck's loading space.
- check the truck's loading capacity. Compare the truck's loading capacity with the weight on the type plate of the unit.
- check that there are sufficient fixation points on the truck's loading floor
- check that the loaded height is OK in relation to the proposed transport route (passage height of bridges)

Lifting equipment/tools

- Before lifting a unit, all loose or pivoting parts, e.g. doors, have to be securely fastened first.
- To lift a unit, apply crane hooks or lifting beam meeting local safety regulations and attach these on the unit's lifting eyes.
- Depending on the product category (see technical specifications) the unit has to be lifted on bottom with a lifting beam or on top with a chain hoist (refer to reverse page).
- It is also allowed to lift the unit with a forklift using the forklift slots when the proposed forklift has adequate lifting capacity.
- When lifting on bottom, always make sure to position the lifting beam with the gravity sticker on the unit. The chain of the lifting beam contains markings indicating where to adjust.

- Lifting hooks, eyes, shackles, etc., should never be bent and only subjected to stress in line with their load axis design. The capacity of a lifting device diminishes when the lifting force is applied at an angle to its load axis. Never allow sharp bends in lifting cables, chains or ropes.

Lifting

- For maximum safety and efficiency of the lifting apparatus, all lifting members have to be applied as close to perpendicular as possible. If required, a lifting beam has to be applied between hoist and load.
- A hoist has to be installed in such a way that the object will be lifted perpendicularly. If that is not possible, necessary precautions must be taken to prevent load-swinging, e.g. by using two hoists, each at approximately the same angle not exceeding 30° from the vertical.
- Helicopter lifting is not allowed.
- Lifting acceleration and braking has to be kept within safe limits.
- Never leave a load hanging on a hoist.

Securing

- For securing the unit, use the container twist locks on the truck.



TECHNICAL SPECIFICATIONS

	Lifting on top	Lifting on bottom
	QAC 500 – QAC1250	DNS – ZH 10000 trafo container – TwinAir
Weight	See data plate	
Dimensions	See data plate	

Local transport regulations always prevail. This Loading Guideline does not replace the Instruction Manual delivered with the machine. Please refer to the Instruction Manual for complete safety, operation and maintenance guidelines. For a copy please contact: <http://www.atlascopcorental.com/>

LIFTING ON BOTTOM

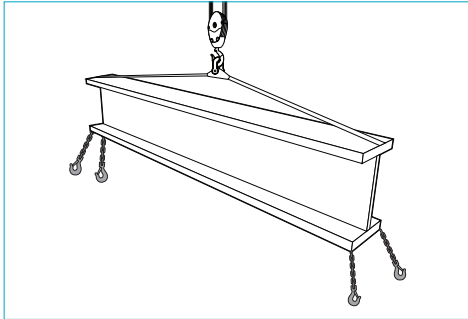

Liftingbeam

LIFTING ON TOP

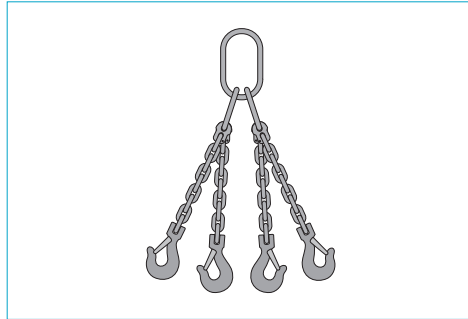

Four strand chain hoist

TRUCK TYPES

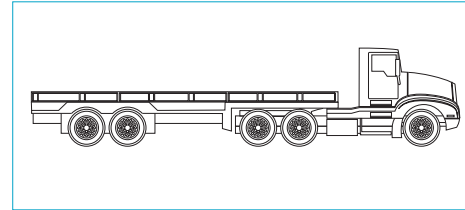

Open trailer

WAYS OF FIXATION

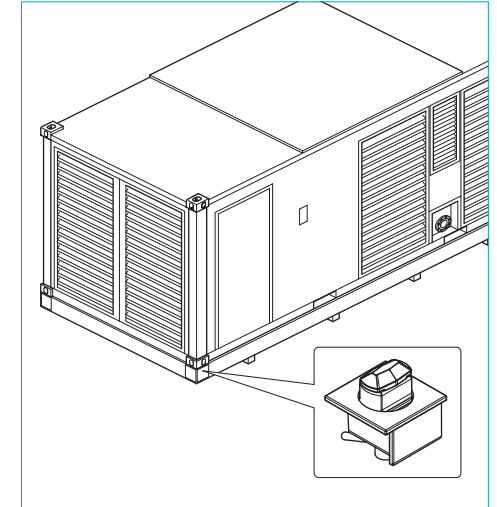

Fixation with twistlocks

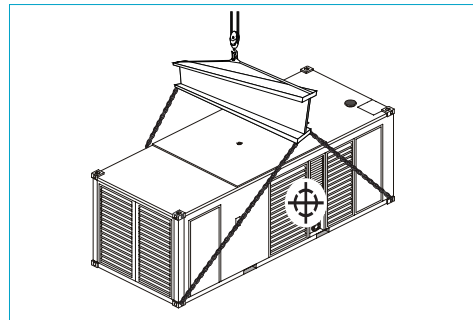

Align with centre of gravity sticker

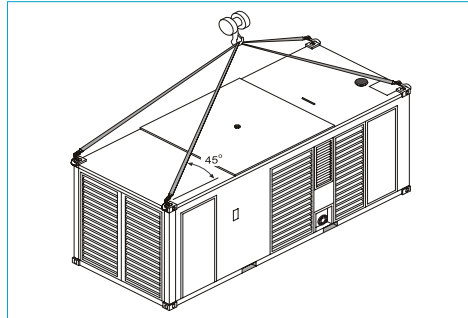

Lifting container with crane

FIXATION TOOLS

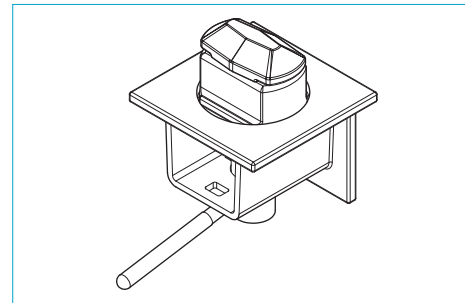

Twistlock, if present

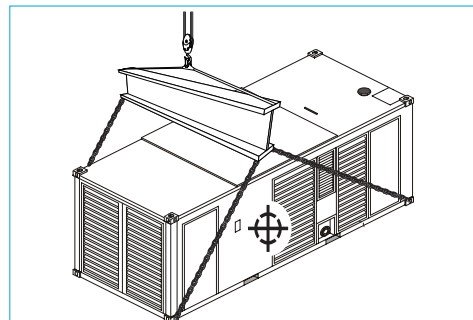

Align with centre of gravity sticker

MOVING

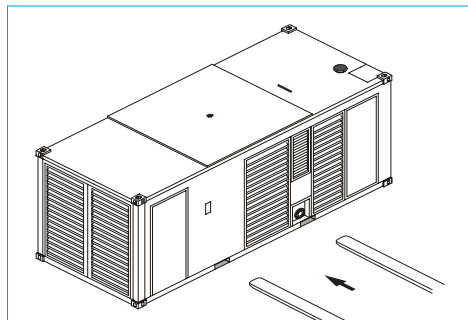

Moving container with fork lift (depending on the max. weight capacity)

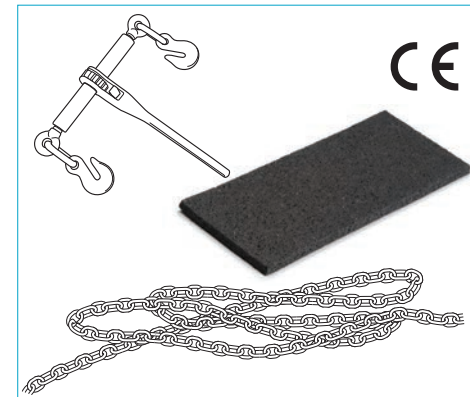

Use mats and CE approved chains

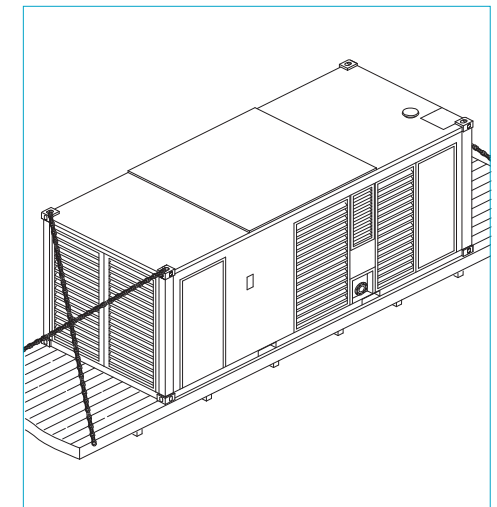

Fixation of container with chains

SAFETY INSTRUCTIONS



Truck

To determine whether a truck is suited for transporting the unit:

- compare the truck's loading capacity with the weight on the type plate of the unit.
- check that there are sufficient fixation points on the truck's loading floor
- check that the loaded height is OK in relation to the proposed transport route (passage height of bridges)

Lifting equipment/tools

- Before lifting a unit, all loose or pivoting parts, e.g. doors have to be securely fastened first.
- To lift a unit; apply crane hooks or lifting shackles meeting local safety regulations and attach these to the unit's lifting eyes. Never allow sharp bends in lifting cables, chains or ropes.
- It is also allowed to lift the unit with a forklift using the forklift slots when the proposed forklift has adequate lifting capacity.
- Lifting hooks, eyes, shackles, etc., should never be bent and only subjected to stress in line with their load axis design. The capacity of a lifting device diminishes when the lifting force is applied at an angle to its load axis.

Lifting

- For maximum safety and efficiency of the lifting apparatus, all lifting members have to be applied as close to perpendicular as possible. If required, a lifting beam has to be applied between hoist and load.
- A hoist has to be installed in such a way that the object will be lifted perpendicularly. If that is not possible, necessary precautions must be taken to prevent load-swinging, e.g. by using two hoists, each at approximately the same angle not exceeding 30° from the vertical.
- Helicopter lifting is not allowed.
- Lifting acceleration and breaking has to be kept within safe limits.
- Never leave a load hanging on a hoist.

Securing

- For securing the unit on the truck, use chains or straps, connected crosswise (refer to reverse page).



TECHNICAL SPECIFICATIONS

		QAS 14-20	QAS 30-40	QAS 60 QAS 80 QAS 100	QAS 125 QAS 150 QAS 200	QAS 250 QAS 325 QAS 400	QAS 500
Weight		see data plate					
Dimensions (mm)	L	1860	2100	2850	3378	3955	4800
	W	810	950	1100	1180	1325	1550
	H	960	1170	1582	1705	2130	2300

Local transport regulations always prevail. This Loading Guideline does not replace the Instruction Manual delivered with the machine. Please refer to the Instruction Manual for complete safety, operation and maintenance guidelines. For a copy please contact: <http://www.atlascopcorental.com/>

TRUCK TYPES

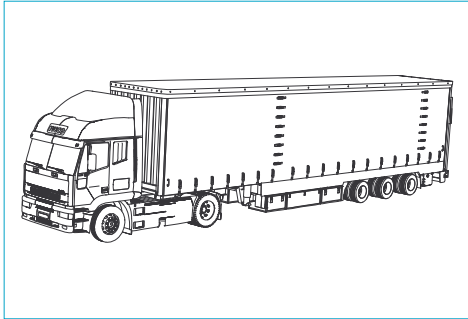

Curtain trailer

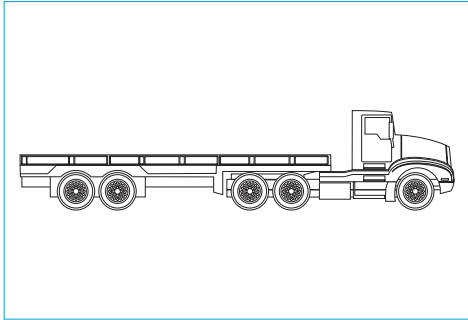

Open trailer

LIFTING

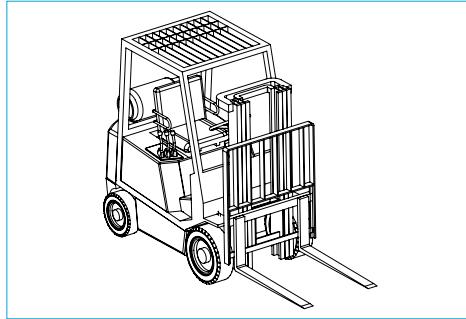

Fork lift

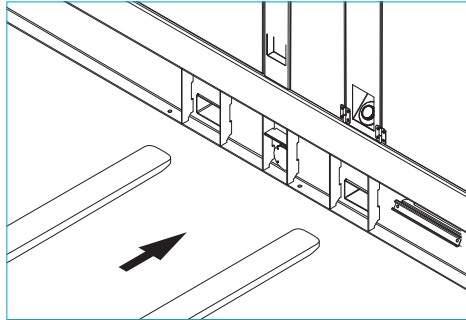

Lifting generator with forklift

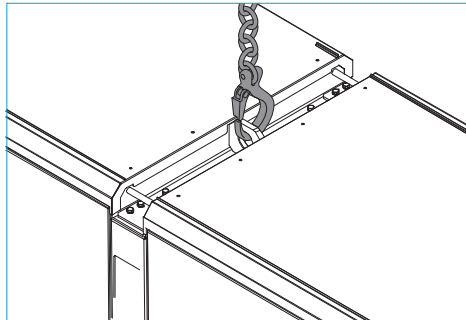

Lifting generator

FIXATION TOOLS

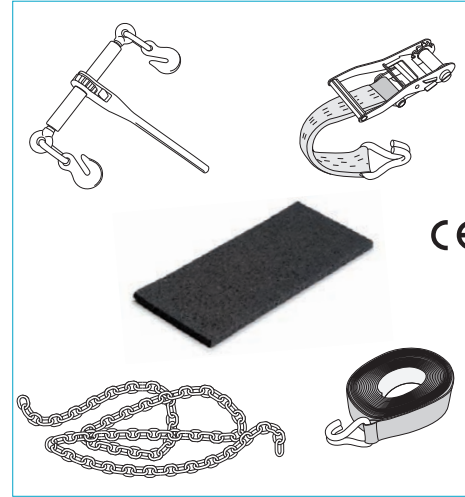

Use mats and CE approved lashing tools (chains or straps)

FIXATION

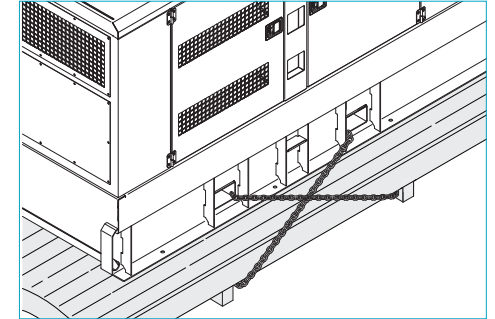

Fixation of generator with chains

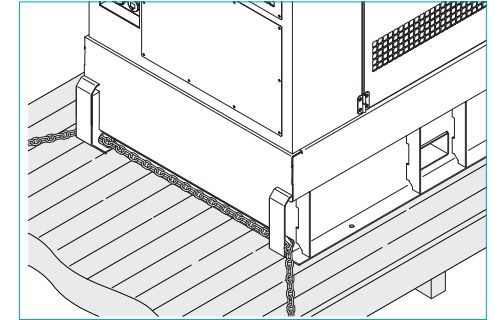

Fixation of generator with chains

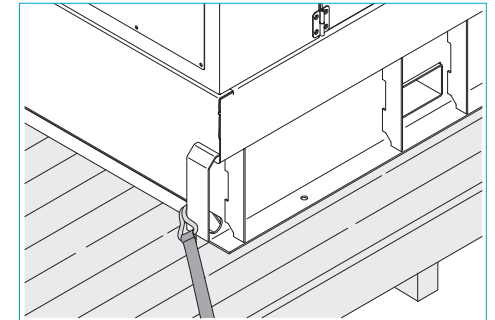

Fixation of generator with straps

Local transport regulations always prevail. This Loading Guideline does not replace the Instruction Manual delivered with the machine. Please refer to the Instruction Manual for complete safety, operation and maintenance guidelines. For a copy please contact: <http://www.atlascopcorental.com/>

! When available, place rubber mats under frame !

SAFETY INSTRUCTIONS



Truck

To determine whether a truck is suited for transport of the unit:

- compare the truck's loading capacity with the weight on the data plate of the unit.
- check that there are sufficient fixation points on the truck's loading floor
- check that the loaded height is OK in relation to the proposed transport route (passage height of bridges)

Before lifting

- Never exceed the maximum towing speed of the unit (refer to local regulations).
- Place the unit on level ground and apply the parking brake before disconnecting the unit from the towing vehicle. Immobilize the unit by placing chocks in front of and/or behind the wheels. Position the tow bar vertically and lock it.
- Before lifting a unit, all loose or pivoting parts, e.g. doors and tow bar, have to be securely fastened first.

Lifting equipment/tools

- Check that the intended lifting tools are designed for the weight to be lifted.
- To lift a unit; apply crane hooks or lifting shackles meeting local safety regulations and attach these to the unit's lifting eyes. Never allow sharp bends in lifting cables, chains or ropes.
- It is also allowed to lift the unit with a forklift using the forklift slots when the proposed forklift has adequate lifting capacity.

- Lifting hooks, eyes, shackles, etc., should never be bent and only subjected to stress in line with their load axis design. The capacity of a lifting device diminishes when the lifting force is applied at an angle to its load axis.

Lifting

- For maximum safety and efficiency of the lifting apparatus, all lifting members have to be applied as close to perpendicular as possible. If required, a lifting beam has to be applied between hoist and load.
- A hoist has to be installed in such a way that the object will be lifted perpendicularly. If that is not possible, necessary precautions must be taken to prevent load-swinging, e.g. by using two hoists, each at approximately the same angle not exceeding 30° from the vertical.
- Helicopter lifting is not allowed.
- Lifting acceleration and braking has to be kept within safe limits.
- Never leave a load hanging on a hoist.

Securing

- For securing the unit on the trailer, use wooden beam block cradles or wooden chocks to block the wheels and additionally secure the unit with straps or chains on the wheels. Never strap on top of the canopy!
- Per wheel, 2 straps are mandatory (refer to reverse page).



TECHNICAL SPECIFICATIONS

	PTS 800 - PTS 916 - PTS 1600 - PNS 1250 - PTE 1500
Weight	see data plate
Dimensions L x W x H (mm)	5240 x 2210 x 2350

Local transport regulations always prevail. This Loading Guideline does not replace the Instruction Manual delivered with the machine. Please refer to the Instruction Manual for complete safety, operation and maintenance guidelines. For a copy please contact: <http://www.atlascopcorental.com/>

TRUCK TYPES

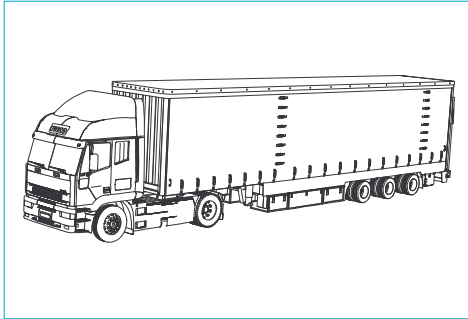

Curtain trailer

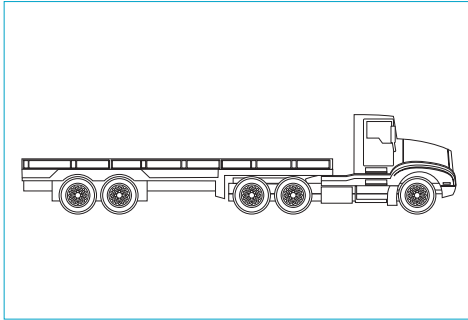

Open trailer

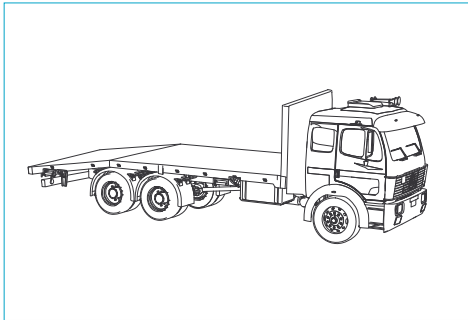

Winch truck

LOADING

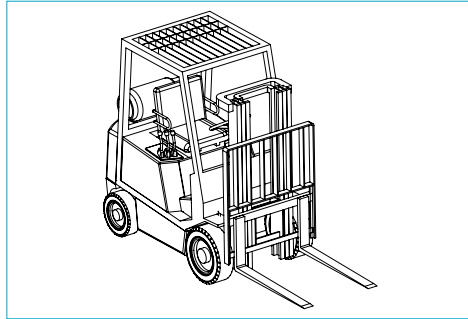

Fork lift

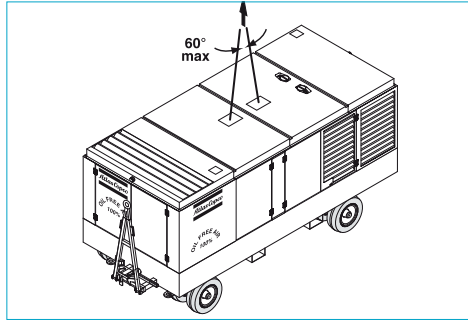

Max. apex angle of hoisting sling is 60°

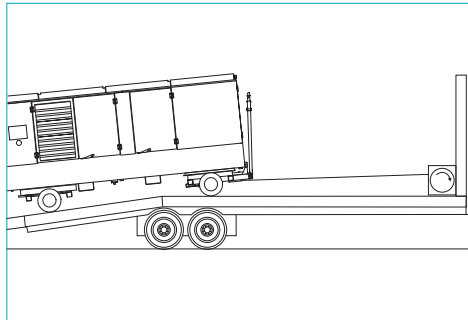

Loading by winch

FIXATION TOOLS

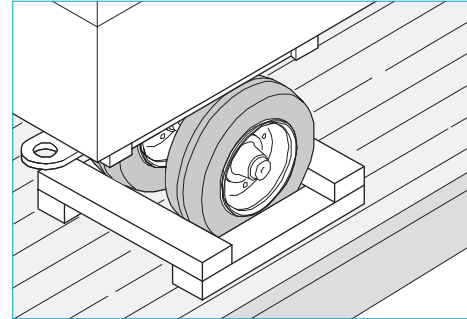

Use wooden block cradle when loading by lifting

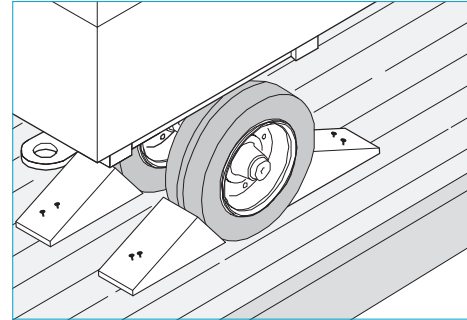

Use nailed, wooden chocks only with wooden floor

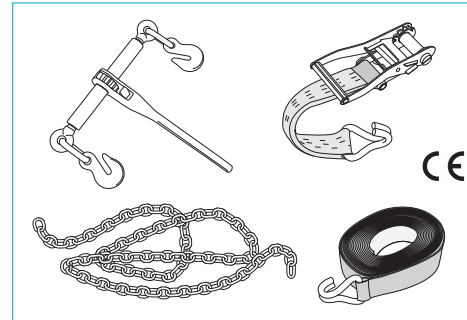

Use CE-approved lashing tools (chains or straps)

WAYS OF FIXATION

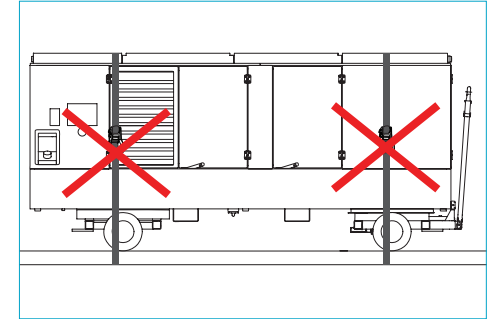

Never strap on top of canopy

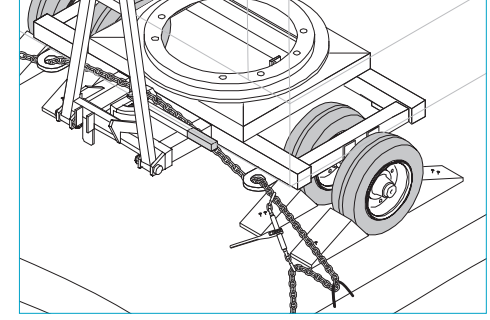

Fixation with chains to trailer frame (to the outside)

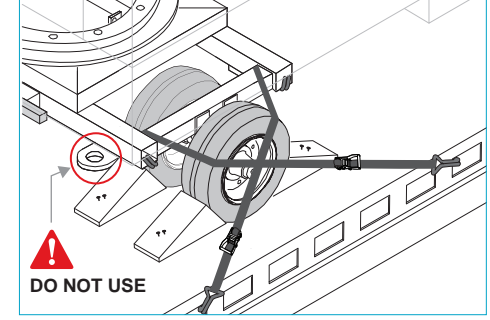

Fixation with crossed straps to trailer frame

SAFETY INSTRUCTIONS



Truck

To determine whether a truck is suited for transport of the unit:

- compare the truck's loading capacity with the weight on the data plate of the unit.
- check that there are sufficient fixation points on the truck's loading floor
- check that the loaded height is OK in relation to the proposed transport route (passage height of bridges)

Before lifting

- Never exceed the maximum towing speed of the unit (refer to local regulations).
- Place the unit on level ground and apply the parking brake before disconnecting the unit from the towing vehicle. Immobilize the unit by placing chocks in front of and/or behind the wheels. Position the tow bar vertically and lock it.
- Before lifting a unit, all loose or pivoting parts, e.g. doors and tow bar, have to be securely fastened first.

Lifting equipment/tools

- To lift a unit; apply crane hooks or lifting shackles meeting local safety regulations and attach these to the unit's lifting eyes. Never allow sharp bends in lifting cables, chains or ropes.
- It is also allowed to lift the unit with a forklift using the forklift slots when the proposed forklift has adequate lifting capacity.

- Lifting hooks, eyes, shackles, etc., should never be bent and only subjected to stress in line with their load axis design. The capacity of a lifting device diminishes when the lifting force is applied at an angle to its load axis.

Lifting

- For maximum safety and efficiency of the lifting apparatus, all lifting members have to be applied as close to perpendicular as possible. If required, a lifting beam has to be applied between hoist and load.
- A hoist has to be installed in such a way that the object will be lifted perpendicularly. If that is not possible, necessary precautions must be taken to prevent load-swinging, e.g. by using two hoists, each at approximately the same angle not exceeding 30° from the vertical.
- Helicopter lifting is not allowed.
- Lifting acceleration and braking has to be kept within safe limits.
- Never leave a load hanging on a hoist.

Securing

- For securing the unit on the trailer, use wooden beam block cradles or wooden chocks to block the wheels and additionally secure the unit with straps or chains. (Refer to reverse page).



TECHNICAL SPECIFICATIONS

	X(A,R)(M,T,H,V)S 366-476	XR(V,X,Y) 566-606
Weight	see data plate	
Dimensions L x W x H (mm)	4928 x 2150 x 2479	5369 x 2251 x 2506

Local transport regulations always prevail. This Loading Guideline does not replace the Instruction Manual delivered with the machine. Please refer to the Instruction Manual for complete safety, operation and maintenance guidelines. For a copy please contact: <http://www.atlascopcorental.com/>

TRUCK TYPES

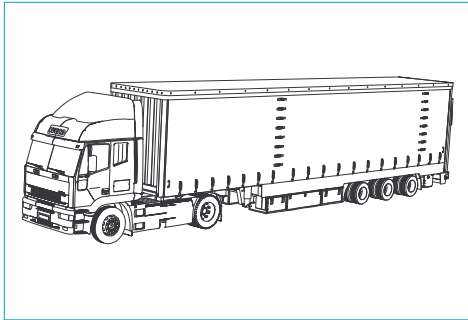

Curtain trailer

LOADING

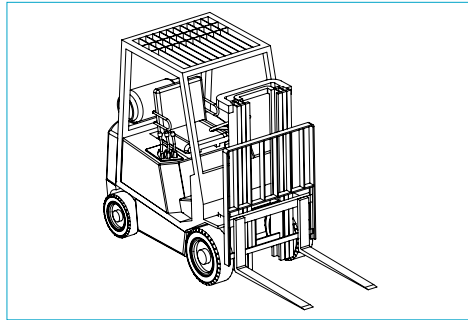

Fork lift

FIXATION TOOLS

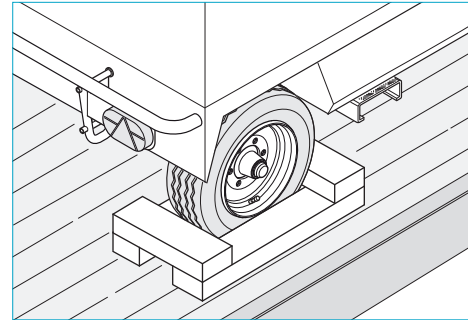

Use wooden block cradle when loading by lifting

WAYS OF FIXATION

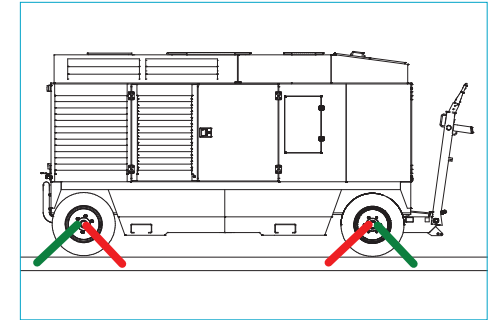

Fixation to the inside (■) or to the outside (■)

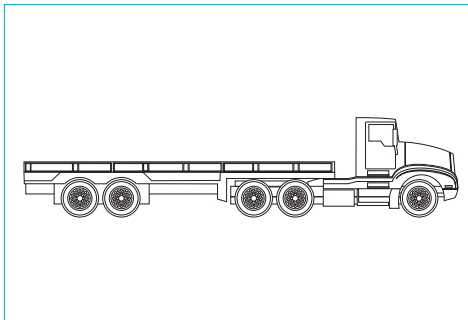

Open trailer

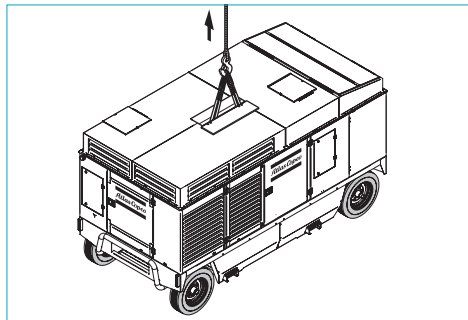

Crane lifting

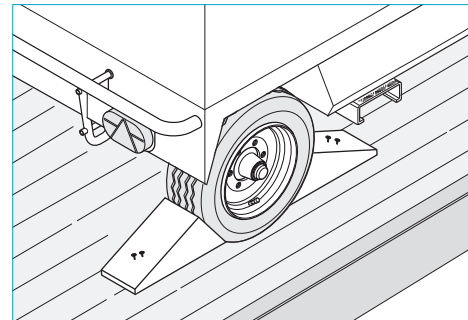

Use nailed, wooden chocks only with wooden floor

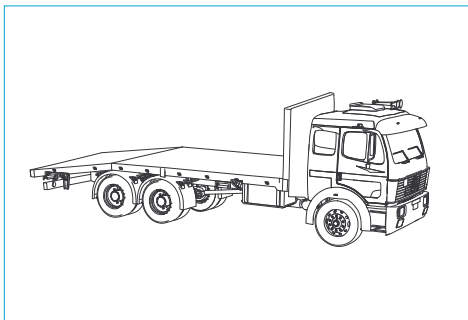
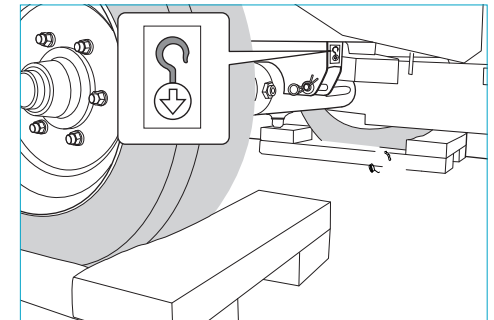

Winch truck

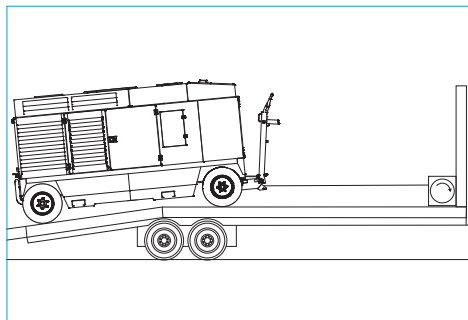

Loading by winch

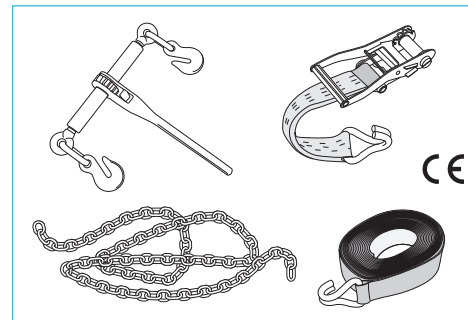

Use CE-approved lashing tools (chains or straps)

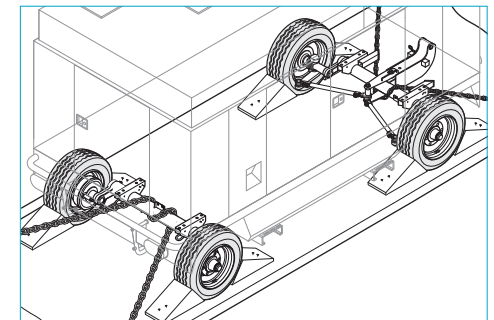

Fixation with chains to trailer frame

X-Series, single axle

SAFETY INSTRUCTIONS



Truck

To determine whether a truck is suited for transport of the unit:

- compare the truck's loading capacity with the weight on the data plate of the unit.
- check that there are sufficient fixation points on the truck's loading floor
- check that the loaded height is OK in relation to the proposed transport route (passage height of bridges)

Before lifting

- Never exceed the maximum towing speed of the unit (refer to local regulations).
- Place the unit on level ground and apply the parking brake before disconnecting the unit from the towing vehicle. Immobilize the unit by placing chocks in front of and/or behind the wheels.
- Before lifting a unit, all loose or pivoting parts, e.g. doors, have to be securely fastened first.

Lifting equipment/tools

- To lift a unit; apply crane hooks or lifting shackles meeting local safety regulations and attach these to the unit's lifting eyes. Never allow sharp bends in lifting cables, chains or ropes.
- It is also allowed to lift the unit at the lifting eye with a forklift using an auxiliary hoisting hook attached to the lifting forks when the proposed forklift has adequate lifting capacity.

 Never lift the unit using the lifting forks under the frame of the unit.

- Lifting hooks, eyes, shackles, etc., should never be bent and only subjected to stress in line with their load axis design. The capacity of a lifting device diminishes when the lifting force is applied at an angle to its load axis.

Lifting

- For maximum safety and efficiency of the lifting apparatus, all lifting members have to be applied as close to perpendicular as possible.
- A hoist has to be installed in such a way that the object will be lifted perpendicularly. If that is not possible, necessary precautions must be taken to prevent load-swinging, e.g. by using two hoists, each at approximately the same angle not exceeding 30° from the vertical.
- Helicopter lifting is not allowed.
- Lifting acceleration and braking has to be kept within safe limits.
- Never leave a load hanging on a hoist.

Securing

- For securing the unit on the trailer, you may use wooden beam block cradles or wooden chocks to block the wheels and additionally secure the unit with straps. (Refer to reverse page).



TECHNICAL SPECIFICATIONS

	XAS 37-97	XA(H)S 107-137	XA(T,H,V)S 146-186	XA(M,H)S 237-287	XA(M,T,H,V)S 307-407
Weight	see data plate				
Dimensions (mm)	L	3483	4279	4212	5043
	W	1417	1677	1701	1987
	H	1360	1479	1753	2036

Local transport regulations always prevail. This Loading Guideline does not replace the Instruction Manual delivered with the machine. Please refer to the Instruction Manual for complete safety, operation and maintenance guidelines. For a copy please contact: <http://www.atlascopcorental.com/>

TRUCK TYPES

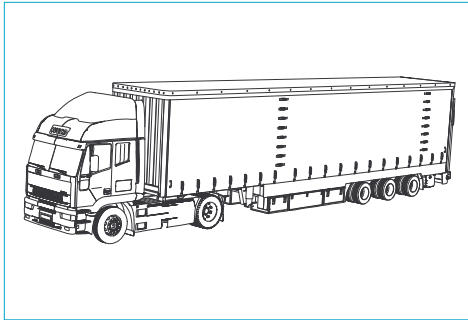

Curtain trailer

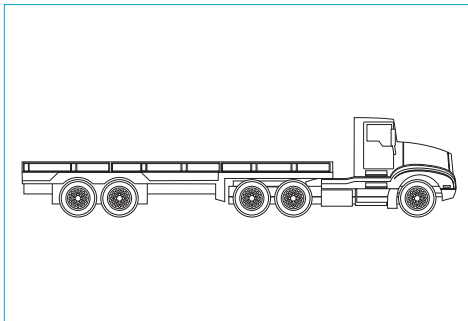

Open trailer

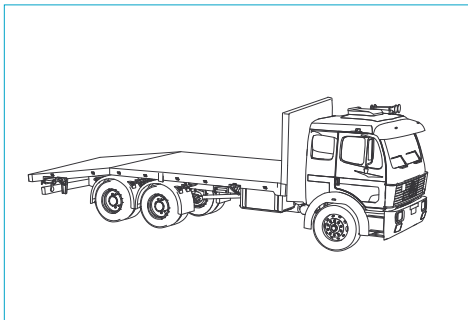

Winch truck

LOADING

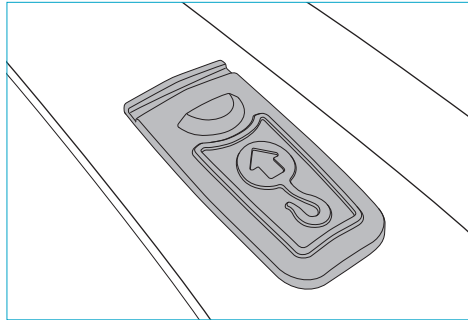

Location lifting eye

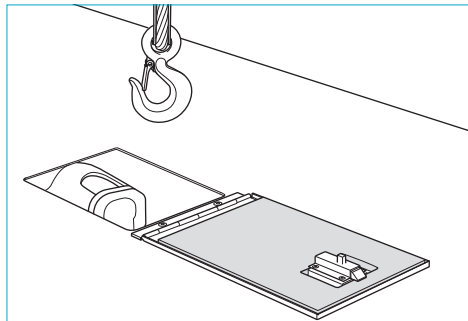

Lifting eye

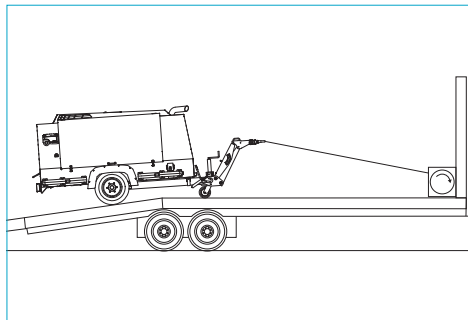

Loading by winch

FIXATION TOOLS

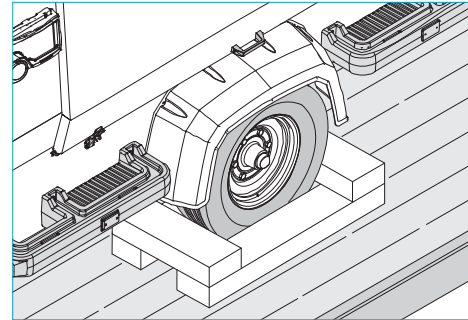

Non-obligatory wooden block cradle

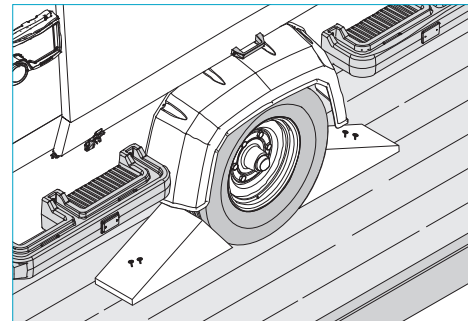

Non-obligatory nailed, wooden chocks (wooden floor)

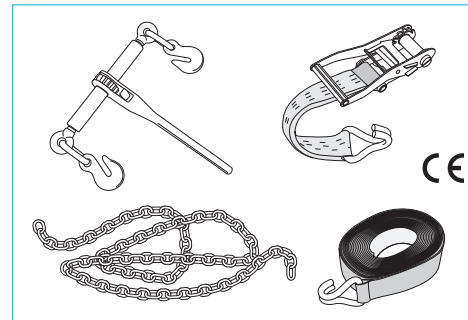

Use CE-approved lashing tools (chains or straps)

WAYS OF FIXATION

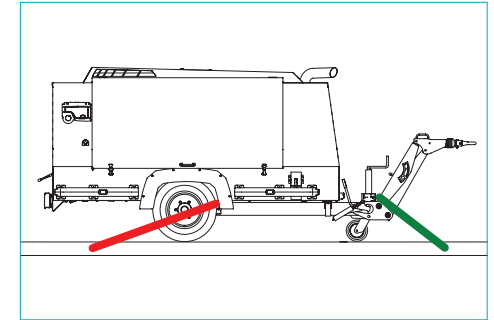

Fixation of axle (■) and towbar (■)

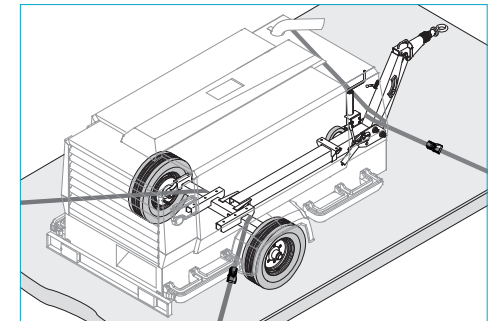

SAFETY INSTRUCTIONS



Truck

To determine whether a truck is suited for transport of the unit:

- compare the dimensions of the unit with the truck's loading space.
- check the truck's loading capacity. To determine the loading weight, the weight on the unit's data plate has to be increased with the weight of the protective frame.
- For loading volumes less than 10 m³: add 500 kg
- For loading volumes between 10 m³ and 20 m³: add 800 kg
- For loading volumes between 20 m³ and 30 m³: add 1,000 kg
- check that there are sufficient fixation points on the truck's loading floor
- check that the loaded height is OK in relation to the proposed transport route (passage height of bridges)

Lifting equipment/tools

- Before lifting a unit, all loose or pivoting parts, e.g. doors, have to be securely fastened first.
- To lift a unit, apply crane hooks or lifting shackles meeting local safety regulations and attach these to the unit's lifting eyes. Never allow sharp bends in lifting cables, chains or ropes.
- It is also allowed to lift the unit with a forklift using the forklift slots when the proposed forklift has adequate lifting capacity.

- Lifting hooks, eyes, shackles, etc., should never be bent and only subjected to stress in line with their load axis design. The capacity of a lifting device diminishes when the lifting force is applied at an angle to its load axis.

Lifting

- For maximum safety and efficiency of the lifting apparatus, all lifting members have to be applied as close to perpendicular as possible. If required, a lifting beam has to be applied between hoist and load.
- A hoist has to be installed in such a way that the object will be lifted perpendicularly. If that is not possible, necessary precautions must be taken to prevent load-swinging, e.g. by using two hoists, each at approximately the same angle not exceeding 30° from the vertical.
- Helicopter lifting is not allowed.
- Lifting acceleration and braking has to be kept within safe limits.
- Never leave a load hanging on a hoist.

Securing

- Use chains for securing the unit on the trailer. (Refer to reverse page).

Z & G-units with lifting frame



TECHNICAL SPECIFICATIONS

All units	
Weight	see data plate and add frame weight according information in left column
Dimensions	to be measured on site

Local transport regulations always prevail. This Loading Guideline does not replace the Instruction Manual delivered with the machine. Please refer to the Instruction Manual for complete safety, operation and maintenance guidelines. For a copy please contact: <http://www.atlascopcorental.com/>

Z & G-units with lifting frame

TRUCK TYPES

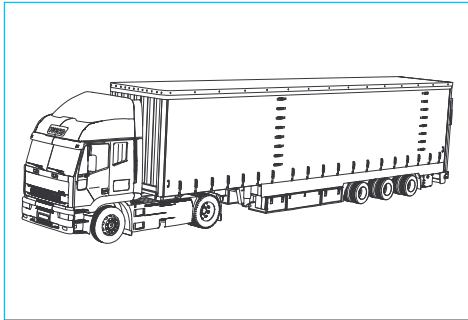

Curtain trailer

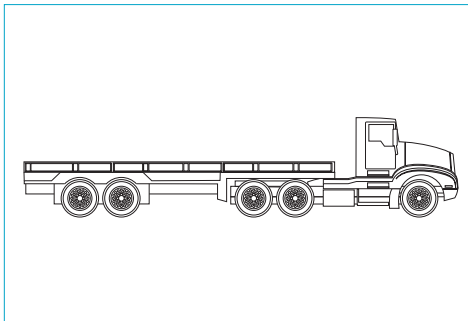

Open trailer

LIFTING

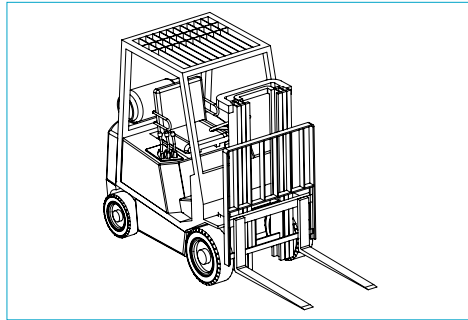

Fork lift



Four strand chain hoist

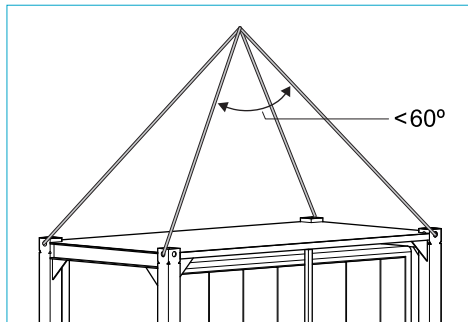

Max. apex angle of hoisting chain is $< 60^\circ$

FIXATION TOOLS

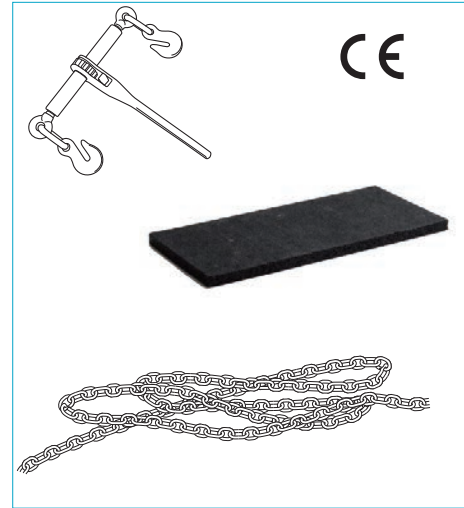

Use mats and CE approved chains

WAYS OF FIXATION

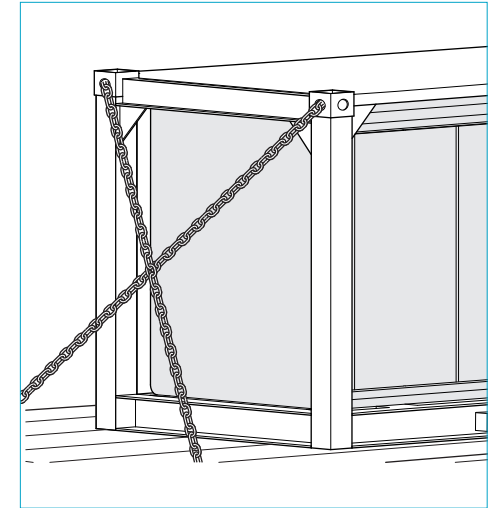

Fixation of container with chains

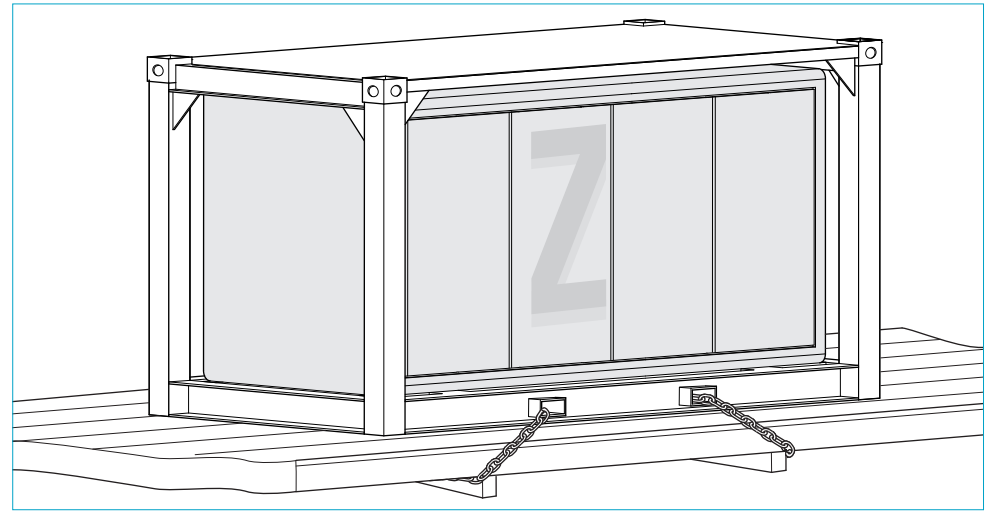

Fixation of container with chains

Local transport regulations always prevail. This Loading Guideline does not replace the Instruction Manual delivered with the machine. Please refer to the Instruction Manual for complete safety, operation and maintenance guidelines. For a copy please contact: <http://www.atlascopcorental.com/>

! When available, place rubber mats under frame !

SAFETY INSTRUCTIONS



Truck

To determine whether a truck is suited for transport of the unit:

- compare the dimensions of the unit with the truck's loading space.
- check the truck's loading capacity. To determine the loading weight, the weight on the unit's data plate has to be increased with the weight of the protective frame.
- For loading volumes less than 10 m³: add 500 kg
- For loading volumes between 10 m³ and 20 m³: add 800 kg
- For loading volumes between 20 m³ and 30 m³: add 1,000 kg
- check that there are sufficient fixation points on the truck's loading floor
- check that the loaded height is OK in relation to the proposed transport route (passage height of bridges)

Lifting equipment/tools

- Before lifting a unit, all loose or pivoting parts, e.g. doors, have to be securely fastened first.
- It is ONLY allowed to lift the unit with a forklift using the forklift slots when the proposed forklift has adequate lifting capacity.
- The capacity of a lifting device diminishes when the lifting force is applied at an angle to its load axis.

Lifting

- For maximum safety and efficiency of the lifting apparatus, all lifting members have to be applied as close to perpendicular as possible.
- Helicopter lifting is not allowed.
- Lifting acceleration and braking has to be kept within safe limits.

Securing

- For securing the unit on the trailer, use chains or straps. (Refer to reverse page).

Z & G-units with protection frame



TECHNICAL SPECIFICATIONS

All units	
Weight	see data plate and add frame weight according to information in left column on the back
Dimensions	to be measured on site

Local transport regulations always prevail. This Loading Guideline does not replace the Instruction Manual delivered with the machine. Please refer to the Instruction Manual for complete safety, operation and maintenance guidelines. For a copy please contact: <http://www.atlascopcorental.com/>

Z & G-units with protection frame

TRUCK TYPES

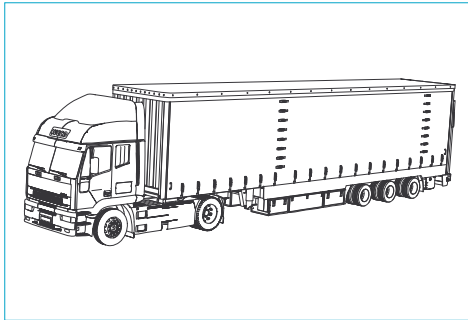

Curtain trailer

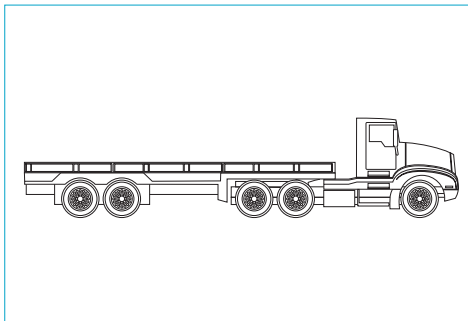

Open trailer

LIFTING

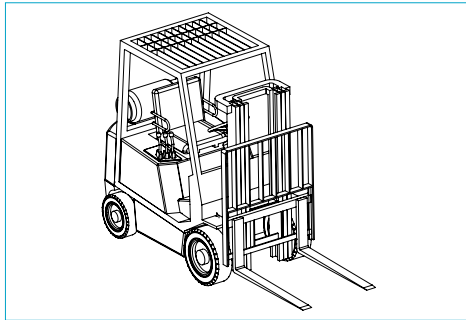

Fork lift

FIXATION TOOLS

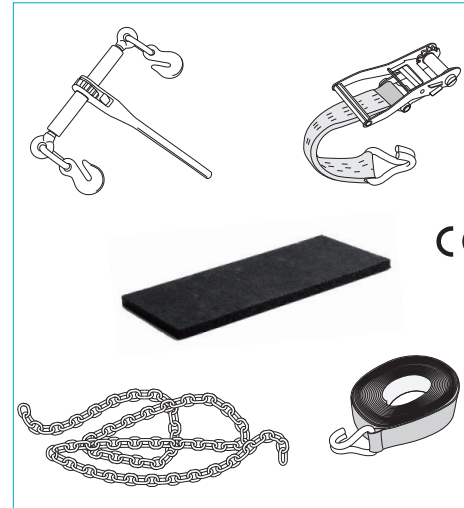

Use mats and CE approved chains or straps

WAYS OF FIXATION

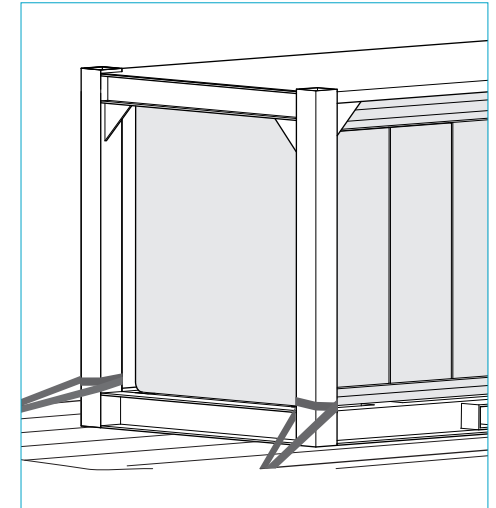

Fixation of container with straps

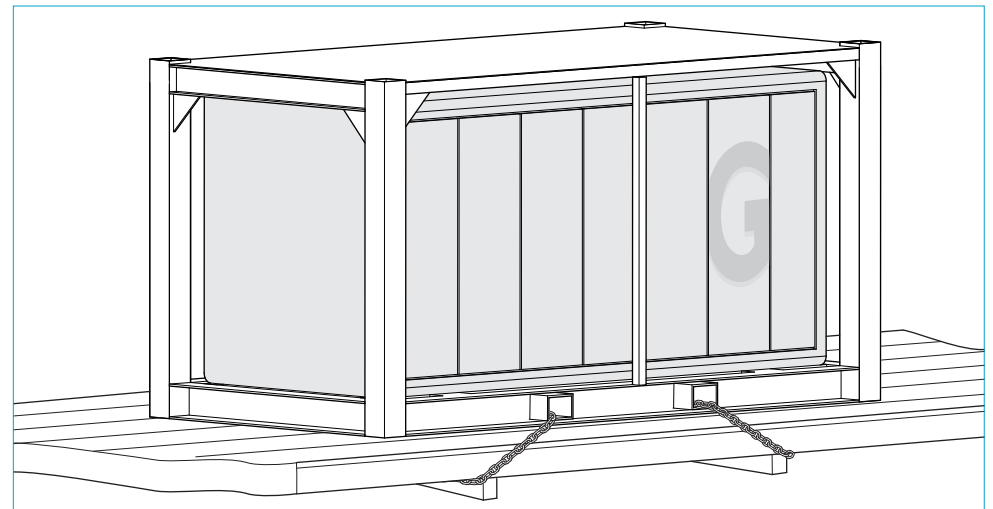

Fixation of container with chains

Local transport regulations always prevail. This Loading Guideline does not replace the Instruction Manual delivered with the machine. Please refer to the Instruction Manual for complete safety, operation and maintenance guidelines. For a copy please contact: <http://www.atlascopcorental.com/>

! When available, place rubber mats under frame !