

STANDARD TERMS OF PURCHASE

1. DEFINITIONS AND FORMATION OF CONTRACT

1.1 In these terms:

“ATLAS COPCO” means the Atlas Copco entity named in the Purchase Order.

“Atlas Copco Property” means materials, equipment, tooling, or other property belonging to Atlas Copco or for which Atlas Copco is responsible.

“Conditions” means the terms and conditions set out herein.

“Contract” means the terms and conditions for the supply of Goods and/or Services to Atlas Copco, as set out in the Purchase Order for such Goods or Services, and these Conditions. If there is an inconsistency between the terms of the Purchase Order and these Conditions, the former shall prevail.

“Goods” means the goods described in a Purchase Order.

“Purchase Order” means Atlas Copco’s official purchase order to which these Conditions are annexed issued by Atlas Copco to the Supplier and shall include the Conditions and any drawings, schedules, Specifications, and other attachments thereto.

“Services” means the services described in a Purchase Order.

“Specification” means the specifications for the Goods and/or the Services as set out or referenced in a Purchase Order.

“Supplier” means the company or person to whom a Purchase Order is addressed.

1.2. A Contract shall be formed on acceptance of the Purchase Order by the Supplier.

1.3 Any of the following acts shall constitute conclusive acceptance by the Supplier of the Purchase Order and the Conditions; any written (including electronic) or oral acceptance, or commencement of the supply of Goods or performance of the Services.

1.4 These Conditions shall apply to the Contract to the exclusion of any other terms on which any quotation has been given to Atlas Copco or subject to which a Purchase Order is accepted or purported to be accepted by the Supplier.

2. INSPECTION, DELIVERY AND PERFORMANCE OF GOODS

2.1 The Supplier grants Atlas Copco the right to inspect any Goods at any time prior to delivery at Supplier’s premises or elsewhere. The Supplier shall give Atlas Copco reasonable advance notice of when any completed Goods will be ready for inspection. Inspection by Atlas Copco of any Goods shall not relieve the Supplier of responsibility or liability for those Goods and shall not imply acceptance thereof. Atlas Copco shall be entitled to waive such right of inspection prior to delivery, without prejudice to its right to reject Goods after delivery.

2.2 Supplier shall deliver the Goods in accordance with (i) the prices and delivery schedules stated in Purchase Order and (ii) Incoterms 2010 DDP the site specified in the Purchase Order and (iii) the Contract.

2.3 Delivery dockets, including the following information, shall accompany all Goods: Purchase Order number, description of Goods and name of Supplier, unit of measure specifying volume, quantity, and delivery point for the Goods.

2.4 Title to all or any part of the Goods and/or Services shall pass to Atlas Copco on the earlier of (i) payment for such Goods or Services or part thereof; and (ii) delivery of such Goods or Services. Where title to all or any part of the Goods has passed to Atlas Copco but the Goods remain in possession of the Supplier, the Supplier shall clearly label the Goods as the property of Atlas Copco and store the Goods separately from all other goods.

Atlas Copco (Malaysia) Sdn. Bhd. 198201007501 (87259-U)

Head office	KL Hub Shared Finance	Branches	Penang	Johor
26, Jalan Anggerik Mokara 31/47, Seksyen 31 Kota Kemuning 40460, Shah Alam Selangor West Malaysia Tel: +603 5123 8888	Lot 16, Jalan Anggerik Vanilla 31/94 Seksyen 31, 40460 Shah Alam Selangor West Malaysia Tel: +603 5525 9758		No. 531 & 533, Jalan 11600, Penang West Malaysia Tel: +604 293 9883	No 1, Jalan Tiong Emas 1 Kawasan Perindustrian 81100 Johor Bahru, Johor West Malaysia Tel: +607 364 9989

- 2.5 Atlas Copco may reject any Goods delivered which are not in accordance with the Contract, and shall not be deemed to have accepted any Goods, notwithstanding that Atlas Copco has paid for the Goods, until Atlas Copco has had a reasonable time to inspect them following delivery or, if later, within a reasonable time after any latent defect in the Goods has become apparent.
- 2.6 Without prejudice to any other rights Atlas Copco may have under the Contract or otherwise, if the Supplier fails to deliver the Goods in accordance with the terms of the Contract or Atlas Copco rejects the Goods pursuant to Condition 2.5, then Atlas Copco shall be entitled, at its option, to:
- 2.6.1 require the Supplier, at its cost, to remove, repair or replace the undelivered or rejected Goods, as expeditiously as reasonably practicable which Goods shall then immediately be held at the risk of the Supplier; and/or
 - 2.6.2 obtain replacement goods from a third party and be reimbursed on demand by the Supplier for all related reasonable costs and expenses; and/or
 - 2.6.3 terminate the Contract forthwith and refuse to accept any further consignment of Goods under the Contract; and/or
 - 2.6.4 suspend the Contract and refuse to accept any further delivery of Goods from the Supplier.
- 2.7 The Supplier shall comply with all package specifications issued by Atlas Copco from time to time and the majority of all packaging supplied by the Supplier shall be recoverable or recyclable and, if requested by Atlas Copco, collected from Atlas Copco free of charge.
- 2.8 Atlas Copco reserves the right to call for certificates of raw materials and test certificates for materials and equipment used in the manufacture of the Goods.

3. PERFORMANCE OF THE SERVICES

- 3.1 Without prejudice to any other rights Atlas Copco may have under the Contract or otherwise, if the Supplier fails to perform the Services in accordance with the terms of the Contract and by the specified date or Atlas Copco rejects the Services, then Atlas Copco shall be entitled, at its option, to:
- 3.1.1 require the Supplier, at its cost, to re-perform the Services as expeditiously as reasonably practicable; and/or
 - 3.1.2 obtain services from a third party and be reimbursed by the Supplier for all related reasonable costs and expenses; and/or
 - 3.1.3 terminate the Contract forthwith and refuse to accept any further performance of Services under the Contract.
- 3.2 If the Supplier's employees are required to work on a Atlas Copco site:
- 3.2.1 Materials used are at the Supplier's risk until acceptance by Atlas Copco.
 - 3.2.2 The Supplier shall be responsible for the safe keeping of all property belonging to it or within its control including, without limitation, plant, equipment, tools and documents and shall ensure that the same are properly maintained and are in good working order and repair and are accompanied by all necessary certificates and records. The Supplier shall perform the Services to ensure that all such property is handled and stored in such a manner so that it does not cause injury, loss or death to persons or loss or damage to property.
 - 3.2.3 The Supplier shall be responsible for ensuring at its own cost that all personnel engaged in the Services are supplied with and wear all safety gear and protective clothing appropriate to the Services to be provided. The Supplier shall not use any tools, equipment or other property belonging to or within the control of Atlas Copco without the written consent of Atlas Copco. In the event that the Supplier uses such property, the Supplier will be responsible for its use and safekeeping.

Atlas Copco (Malaysia) Sdn. Bhd. 198201007501 (87259-U)

Head office	KL Hub Shared Finance	Branches	Penang	Johor
26, Jalan Anggerik Mokara 31/47, Seksyen 31 Kota Kemuning 40460, Shah Alam Selangor West Malaysia Tel: +603 5123 8888	Lot 16, Jalan Anggerik Vanilla 31/94 Seksyen 31, 40460 Shah Alam Selangor West Malaysia Tel: +603 5525 9758		No. 531 & 533, Jalan 11600, Penang West Malaysia Tel: +604 293 9883	No 1, Jalan Tiong Emas 1 Kawasan Perindustrian 81100 Johor Bahru, Johor West Malaysia Tel: +607 364 9989



- 3.2.4 The Supplier shall comply with Atlas Copco’ Rules and Regulations at Atlas Copco’ sites, details of which will be made available. A permit to work must be obtained from Atlas Copco prior to commencement of any work on site. Particular attention must be paid to the site safety rules, “No Smoking” requirements and other warning signs. The Supplier’s employees shall attend such safety training as may be required by Atlas Copco.
- 3.2.5 Atlas Copco shall have the right to request the removal of any individual working at an Atlas Copco site without giving any reason.
- 3.2.6 The Supplier shall at its cost, when required by Atlas Copco, carry away all unwanted material arising from the execution of any works by the Supplier, and shall at all times leave the site clear and tidy to Atlas Copco’ satisfaction. In carrying out these duties the Supplier shall comply with all relevant legislation, including environmental and waste disposal laws and regulations and warrants that it is properly licensed and registered to transport and store controlled and special waste arising in connection with the Services.

4. PRICE AND PAYMENT

- 4.1 The price(s) for the Goods and Services shall be specified in the Purchase Order and shall remain fixed for the duration of the Contract.
- 4.2 The price payable for the Goods and Services shall be:
 - 4.2.1 exclusive of sales and services tax (which shall be payable by Atlas Copco subject to receipt of a SST invoice) or other sales tax; and
 - 4.2.2 inclusive of all charges for packaging, packing, shipping, carriage, insurance and delivery of the Goods and all duties, licences, permits and taxes (other than SST) as may be payable in respect of Goods or Services from time to time.
- 4.3 Atlas Copco shall make payment for the Goods or Services within 60 days of receipt of Supplier’s duly completed and accurate invoice (including the Purchase Order number, delivery note number and Supplier’s SST number) which invoices shall only be issued by the Supplier following delivery of the relevant Goods to Atlas Copco or following completion of the relevant Services.
- 4.4 Atlas Copco may withhold payments of any disputed or insufficiently documented amounts included in any invoice. Atlas Copco is entitled to set-off against the price sums owed to Atlas Copco by the Supplier.

5. ATLAS COPCO PROPERTY

The Supplier shall be fully responsible for, will maintain and, where relevant, will calibrate any Atlas Copco Property, including the safe and secure storage thereof, whilst in the Supplier’s possession and will promptly replace or repair, as required by Atlas Copco, at the Supplier’s own cost, any Atlas Copco Property lost or damaged by the Supplier. The Supplier shall stamp, tag or otherwise mark all relevant Atlas Copco Property in its possession with Atlas Copco’ name and/or logo as indicia of Atlas Copco’ ownership. The Supplier agrees not to remove these indicia of ownership and store the Atlas Copco Property in a specifically designated area at the Supplier’s premises. The Supplier will return such property immediately on request and will allow access to Atlas Copco’ personnel for the purpose of removing such Atlas Copco Property.

Atlas Copco (Malaysia) Sdn. Bhd. 198201007501 (87259-U)

Head office	KL Hub Shared Finance	Branches	Penang	Johor
26, Jalan Anggerik Mokara 31/47, Seksyen 31 Kota Kemuning 40460, Shah Alam Selangor West Malaysia Tel: +603 5123 8888	Lot 16, Jalan Anggerik Vanilla 31/94 Seksyen 31, 40460 Shah Alam Selangor West Malaysia Tel: +603 5525 9758		No. 531 & 533, Jalan 11600, Penang West Malaysia Tel: +604 293 9883	No 1, Jalan Tiong Emas 1 Kawasan Perindustrian 81100 Johor Bahru, Johor West Malaysia Tel: +607 364 9989

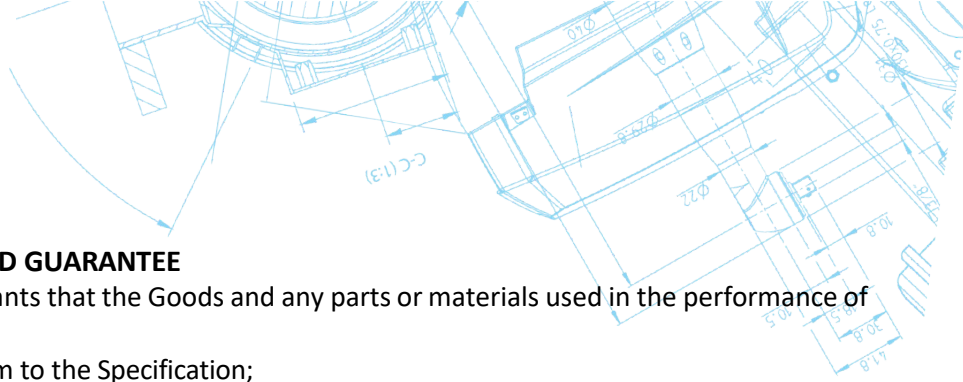

6. WARRANTIES AND GUARANTEE

- 6.1 The Supplier warrants that the Goods and any parts or materials used in the performance of the Services will:
- 6.1.1 conform to the Specification;
 - 6.1.2 be fit for their purpose or any special purpose notified in writing by Atlas Copco to the Supplier;
 - 6.1.3 be new and unused; be of sound materials and workmanship and shall be of satisfactory quality and free from any defects (latent or otherwise);
 - 6.1.4 conform with all legal and regulatory requirements applicable to such Goods or Services (including any parts or materials used in the performance of the Services);
 - 6.1.5 be accompanied by all appropriate information, warnings, instructions and documentation in relation to the use, storage, operation, transportation and disposal of such Goods or parts or materials;
 - 6.1.6 comply with and be properly marked in accordance with any applicable regulations and directives.; and
 - 6.1.7 not contain above 0.1% by weight of any substance in the Candidate List of Substances of Very High Concern (SVHC's) which is published as part of Regulation (EC) No 1907/2006 (REACH) or any substances or materials that is contrary to local applicable laws (including any regulatory guidance, orders, standards, directions, codes of practice or other similar regulatory instrument).
- 6.2 In addition and in relation to the Goods and any parts or materials used in the performance of the Services, the Supplier shall:
- 6.2.1 specify full details regarding all immediate and long term potential hazards or dangers [including, but not limited to, toxicity, flammability, harmful effect due to inhalation or direct contact and whether due to direct or indirect use thereof;]
 - 6.2.2 furnish full details relating to the most appropriate safety precautions to be taken (including in relation to the use or handling thereof);
 - 6.2.3 appropriately and prominently label all receptacles containing dangerous, toxic or otherwise harmful Goods in order to protect those who handle them or who are exposed to them;
 - 6.2.4 notify Atlas Copco prior to the supply of any Goods or use of any materials in the provision of Services, which are manufactured using or containing ozone depleting substances.
- 6.3 The Supplier warrants that all Services (including without limitation design work) will be performed (i) in a safe and workmanlike manner and in accordance with best practice and with the degree of skill, care and diligence exercised by skilled and experienced contractors in the Supplier's industry (ii) in full accordance with all applicable safety laws and regulations, information, warnings and (iii) so as to ensure that the completed works the subject of the Services are free from defects in materials and workmanship and fit for purpose.
- 6.4 Without prejudice to Atlas Copco' other rights under the Contract or otherwise, at Atlas Copco' option, the Supplier shall at its own cost replace or repair any defective Goods and remedy any defect, failure or other detriment to Atlas Copco arising from a breach of the warranties set out in this Condition 6, within 12 months of the date of acceptance of the Goods or completion of performance of the Services. If remedial action is not taken by the Supplier within a reasonable time period (having regard to the nature of the defect), Atlas Copco may proceed to do, or direct a third party to do, the work at the Supplier's risk and expense.

Atlas Copco (Malaysia) Sdn. Bhd. 198201007501 (87259-U)

Head office	KL Hub Shared Finance	Branches	Penang	Johor
26, Jalan Anggerik Mokara 31/47, Seksyen 31 Kota Kemuning 40460, Shah Alam Selangor West Malaysia Tel: +603 5123 8888	Lot 16, Jalan Anggerik Vanilla 31/94 Seksyen 31, 40460 Shah Alam Selangor West Malaysia Tel: +603 5525 9758		No. 531 & 533, Jalan 11600, Penang West Malaysia Tel: +604 293 9883	No 1, Jalan Tiong Emas 1 Kawasan Perindustrian 81100 Johor Bahru, Johor West Malaysia Tel: +607 364 9989

- 6.5 The Supplier shall at its own cost, replace or repair at Atlas Copco's discretion any of the parts or materials so repaired, modified or replaced under this Condition 6 if it is defective within a period of 12 months from the date of acceptance of such repair, modification or replacement.
- 6.6 The Supplier agrees to the pass through or assignment to any subsequent user or purchaser the benefit of any warranty or guarantee to which Atlas Copco is entitled hereunder and the Supplier agrees to enter into such documents as may be necessary to achieve this.
- 6.7 The Supplier shall ensure compliance with all applicable export laws and regulations in the execution of the Contract. The Supplier shall ensure that the Goods and Services to be delivered in accordance with the Contract shall be free from any export restrictions at the time of delivery and any necessary licences, authorisations or certificates obtained to ensure delivery in accordance with the Contract. The Parties agree that any export restrictions do not constitute a Force Majeure event for the Supplier nor lessen the Supplier's obligations in this Condition 6.7. In view of re-exportation of the Goods and Services Supplier shall perform any actions reasonably necessary to assist Atlas Copco. In particular Seller shall provide Buyer, upon request, a written confirmation of the single country of origin for each of the Goods supplied.
- 6.8 The Supplier shall only provide components for use in Atlas Copco products that are compliant with Directive 2011/65/EU of the European Parliament and of the Council of the European Union (the Restriction of Hazardous Substances or "RoHS" Directive) and the local applicable laws (including any regulatory guidance, orders, standards, directions, codes of practice or other similar regulatory instrument). The Supplier shall provide appropriate documentation or proof of such compliance at Atlas Copco request, and update Atlas Copco if compliance status changes.

7. INDEMNITY AND INSURANCE

- 7.1 The Supplier shall hold harmless and indemnify Atlas Copco from and against any liability, loss, costs (including legal fees), expense, damage, death or injury arising in consequence of (i) a defect in design (other than a design made or furnished by Atlas Copco), parts or materials or workmanship of Goods or Services or any breach by the Supplier of the Contract (including any late delivery of Goods and/or performance of Services) or (ii) any negligence, wilful default or wrongful act or omission of the Supplier, its employees, sub-contractors or agents, save to the extent that such liability, loss, cost, expense, damage or injury is due to the negligence of Atlas Copco.
- 7.2 The Supplier agrees to indemnify Atlas Copco from any and all losses sustained by Atlas Copco by reason of any third party claim for injury, death or other damage caused by breach of the warranties within Condition 6 above or by defects in the Goods and/or in the quality of the Services (including any product recall costs incurred by Atlas Copco as a consequence of Atlas Copco receiving defective Goods).
- 7.3 The Supplier shall arrange and maintain, at its own cost, all necessary insurance on terms satisfactory to Atlas Copco.

Atlas Copco (Malaysia) Sdn. Bhd. 198201007501 (87259-U)

Head office	KL Hub Shared Finance	Branches	Penang	Johor
26, Jalan Anggerik Mokara 31/47, Seksyen 31 Kota Kemuning 40460, Shah Alam Selangor West Malaysia Tel: +603 5123 8888	Lot 16, Jalan Anggerik Vanilla 31/94 Seksyen 31, 40460 Shah Alam Selangor West Malaysia Tel: +603 5525 9758		No. 531 & 533, Jalan 11600, Penang West Malaysia Tel: +604 293 9883	No 1, Jalan Tiong Emas 1 Kawasan Perindustrian 81100 Johor Bahru, Johor West Malaysia Tel: +607 364 9989

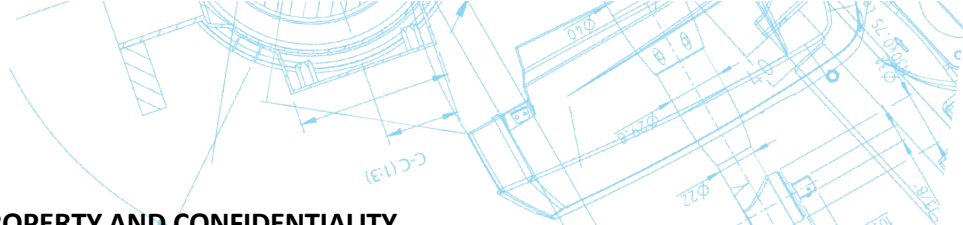

8. INTELLECTUAL PROPERTY AND CONFIDENTIALITY

- 8.1 All intellectual property rights including patents, trade marks, service marks, design rights (whether registered or unregistered), copyright (including any future copyright) and any application for any of the foregoing, arising from work conducted or prepared by the Supplier for Atlas Copco or in tooling supplied by or on behalf of or funded by Atlas Copco shall belong to Atlas Copco and the Supplier agrees at Atlas Copco’ expense to execute all documents and do all such other things as may reasonably be required (i) to assign such rights to Atlas Copco and (ii) to otherwise assist Atlas Copco in applying for and being granted such rights.
- 8.2 Property in all goods and materials (including, without limitation, photographs, drawings, illustrations, film negatives, positives, bromides, recordings, proofs, physical embodiments of computer programmes, tools/tooling and dies) supplied to the Supplier by or on behalf of Atlas Copco, or prepared, manufactured or procured by the Supplier specifically for or in connection with the performance of the Contract for Atlas Copco shall belong to Atlas Copco and shall immediately upon Atlas Copco’ request be handed over to Atlas Copco free of charge and in good condition and no such goods or materials shall be used by Supplier other than in the performance of the Contract or disposed of without the prior written consent of Atlas Copco.
- 8.3 All information and documents provided to the Supplier by Atlas Copco, or otherwise acquired by the Supplier relating to Atlas Copco’ business, or created or produced by or on behalf of the Supplier specifically for or in connection with the performance of the Contract for Atlas Copco shall be kept confidential by the Supplier and shall not be used or caused to be used by the Supplier other than for the purposes of the Contract without first obtaining Atlas Copco’ express consent in writing.
- 8.4 The provisions of Condition 8.3 above shall continue in force notwithstanding termination, however caused, or completion, of the Contract.
- 8.5 The provisions of Condition 8.3 above shall not apply to any information or document in the public domain or coming into the public domain other than through the default of the Supplier.
- 8.6 Without prejudice to Conditions 8.3 and 12.1, if the Supplier assigns or sub-contracts any part of the Contract to any person, the Supplier shall ensure that such person agrees to be bound by these Conditions 8.1 to 8.5 (inclusive) as though a party to the Contract and the Supplier shall indemnify Atlas Copco against any consequences of the Supplier’s failing to do so, including any claim made by such person which it could not make if it were a party to the Contract.
- 8.7 The Supplier warrants that the sale, possession, resale or use of the Goods and/or the performance of the Services to be supplied do not infringe any third party intellectual property rights including patents, designs (whether registered or not), copyright, trade and service marks (whether registered or unregistered), and undertakes to indemnify and hold harmless Atlas Copco, its employees, officers, servants, agents, successors, assigns and customers (“the Indemnified Parties”) against all royalties or licence fees (to the extent not specifically provided for) and against all damages, expenses, losses or costs suffered by the Indemnified Parties or which the Indemnified Parties may be liable in respect of any breach of this warranty. The Supplier will give the Indemnified Parties all such support and assistance as the Indemnified Parties reasonably require in defending a claim that the Goods and Services infringe any third party intellectual property rights. If it should come to Atlas Copco’ knowledge that a claim may arise under this warranty, Atlas Copco reserves the right to terminate the Contract forthwith on written notice and without any liability.

Atlas Copco (Malaysia) Sdn. Bhd. 198201007501 (87259-U)

Head office	KL Hub Shared Finance	Branches	Penang	Johor
26, Jalan Anggerik Mokara 31/47, Seksyen 31 Kota Kemuning 40460, Shah Alam Selangor West Malaysia Tel: +603 5123 8888	Lot 16, Jalan Anggerik Vanilla 31/94 Seksyen 31, 40460 Shah Alam Selangor West Malaysia Tel: +603 5525 9758		No. 531 & 533, Jalan 11600, Penang West Malaysia Tel: +604 293 9883	No 1, Jalan Tiong Emas 1 Kawasan Perindustrian 81100 Johor Bahru, Johor West Malaysia Tel: +607 364 9989

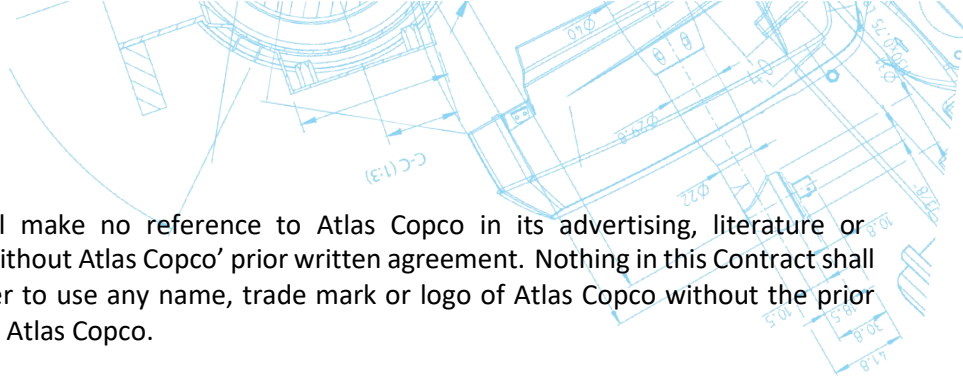

8.8 The Supplier shall make no reference to Atlas Copco in its advertising, literature or correspondence without Atlas Copco's prior written agreement. Nothing in this Contract shall entitle the Supplier to use any name, trade mark or logo of Atlas Copco without the prior written consent of Atlas Copco.

9. SPECIAL TOOLS, JIGS OR FIXTURES

Where special tools, jigs or fixtures are designed, prepared or produced specifically for Atlas Copco, such items shall not be used for any other person (legal or otherwise) or corporation and shall not be stripped, altered or destroyed without the prior written consent of Atlas Copco. Atlas Copco reserves the right to require the Supplier to transfer such items to third parties, nominated by Atlas Copco, and such items shall become the property of Atlas Copco on completion or, if earlier, termination of the Contract.

10. TERMINATION

Atlas Copco shall be entitled to terminate the Contract immediately upon notice and to enter the Supplier's premises and remove any Atlas Copco Property if:

- 10.1 There is a material breach (which includes a series of repeated breaches however small) of a term or any breach of warranty of the Contract by the Supplier; or
- 10.2 Any distress or execution shall be levied on the Supplier's goods or if the Supplier has a receiver, administrator, administrative receiver or manager appointed over the whole or any part of its assets, becomes insolvent, compounds or makes any arrangement with its creditors or commits any act of bankruptcy or is wound up or goes into liquidation or if the Supplier shall suffer any analogous proceedings under foreign law.

Termination of the Contract shall be without prejudice to the accrued rights of Atlas Copco or the Supplier prior to the date of termination.

11. ATLAS COPCO CODE OF CONDUCT AND ETHICAL PURCHASING POLICY

11.1 The Supplier acknowledges that Atlas Copco adheres to a code of ethics (the "Code of Conduct"), adopts the Electronic Industry Citizenship Coalition's Code of Conduct (the EICC Code) and operates an ethical purchasing policy (the "Ethical Purchasing Policy"), covering areas such as business ethics, labour, safety and the environment. Copies of the Ethical Purchasing Policy and the Code of Conduct may be viewed on www.atlascopco.com and the EICC Code may be viewed at www.eicc.info. By supplying goods and/or services to Atlas Copco, the Supplier agrees that it shall adhere to the Code of Conduct, the Ethical Purchasing Policy and the EICC Code. Further, no Atlas Copco employee or officer is authorised to propose to the Supplier or approve conduct inconsistent with the Code of Conduct or Ethical Purchasing Policy.

11.2 Atlas Copco shall have the right to terminate its business relationship and any associated agreements with the Supplier if the Supplier is (or Atlas Copco reasonably believes that the Supplier is) in material breach of the Code of Conduct, the EICC Code or the Ethical Purchasing Policy and, in the case of breaches which are capable of remedy, the Supplier fails to remedy such breach, after written notification by Atlas Copco of such breach, within the cure period specified by Atlas Copco for such remedy. In determining the length of any cure period Atlas Copco shall act reasonably, having regard to the severity and nature of the breach.

Atlas Copco (Malaysia) Sdn. Bhd. 198201007501 (87259-U)

Head office	KL Hub Shared Finance	Branches	Penang	Johor
26, Jalan Anggerik Mokara 31/47, Seksyen 31 Kota Kemuning 40460, Shah Alam Selangor West Malaysia Tel: +603 5123 8888	Lot 16, Jalan Anggerik Vanilla 31/94 Seksyen 31, 40460 Shah Alam Selangor West Malaysia Tel: +603 5525 9758		No. 531 & 533, Jalan 11600, Penang West Malaysia Tel: +604 293 9883	No 1, Jalan Tiong Emas 1 Kawasan Perindustrian 81100 Johor Bahru, Johor West Malaysia Tel: +607 364 9989

- 11.3 The Supplier shall comply with all applicable laws, statutes, and regulations relating to anti-bribery and anti-corruption including but not limited to the Bribery Act 2010, the US Foreign Corrupt Practices Act and the Malaysian Anti-Corruption Commission Act 2009 as amended from time to time, and generally in the course of conducting business behave ethically, with integrity and mutual respect (the “**Relevant Requirements**”); have and shall maintain in place throughout the term of this agreement its own policies and procedures, including but not limited to adequate procedures under the Bribery Act 2010, the US Foreign Corrupt Practices Act and the Malaysian Anti-Corruption Commission Act 2009, to ensure compliance with the Relevant Requirements by any of the Supplier’s employees, officers, representatives and subcontractors and any person who acts for or on its behalf in connection with the performance of the Contract; warrant that no intermediary of any kind was used in the negotiation and conclusion of the Contract. Breach of this clause shall be deemed a material breach of the Contract. Atlas Copco shall be entitled to terminate the Contract or any part of it with immediate effect should it have reasonable grounds to suspect that this clause has been breached by the Supplier.
- 11.4 The Supplier warrants that the tantalum, tin, tungsten and gold in products which they supply to Atlas Copco does not directly or indirectly finance or benefit armed groups that are perpetrators of serious human rights abuses in the Democratic Republic of the Congo or an adjoining country. The Supplier shall exercise due diligence on the source and chain of custody of these minerals and make their due diligence measures available to Atlas Copco upon request.

12. GENERAL

- 12.1 The Supplier may not assign or sub-contract the Contract without the prior written consent of Atlas Copco. Atlas Copco may at any time assign, transfer, charge or deal in any manner with the Contract or any rights under it.
- 12.2 The Supplier may not, without the express prior written consent of Atlas Copco, sell or transfer to a third party the ownership of, or grant or permit to be retained any security interest over, any amount due from Atlas Copco to Supplier.
- 12.3 Time is of the essence for the performance of the Contract by the Supplier.
- 12.4 No term or provision of the Contract shall be enforceable by a third party (being any person other than the parties and their permitted assignees and successors).
- 12.5 No failure or delay on the part of Atlas Copco to exercise any power, right or remedy under the Contract shall operate as a waiver thereof nor shall any single or partial exercise by Atlas Copco of any power, right or remedy preclude any other or further exercise thereof or the exercise of any other power, right or remedy. No waiver by Atlas Copco shall be valid unless made in writing.
- 12.6 The Contract constitutes the entire agreement between Atlas Copco and the Supplier relating to the sale and purchase of Goods and/or Services. No amendment to or a variation of the Contract shall be effective unless agreed in writing by Atlas Copco.
- 12.7 All Contracts, acceptances, correspondence, specifications and other documents shall be in the English language and shall be governed by and construed in accordance with Malaysian law and Atlas Copco and the Supplier hereby submit to the non-exclusive jurisdiction of the Malaysian courts. Atlas Copco shall have the option to bring suit before the Courts of the domicile of the Supplier.
- 12.8 Atlas Copco reserves the right at any time to cancel the Purchase Order in whole or in part or to make any changes. Unless any cancellation or changes arise from the Supplier’s default, Atlas Copco shall pay to the Supplier fair and reasonable compensation for the Supplier’s

Atlas Copco (Malaysia) Sdn. Bhd. 198201007501 (87259-U)

Head office	KL Hub Shared Finance	Branches	Penang	Johor
26, Jalan Anggerik Mokara 31/47, Seksyen 31 Kota Kemuning 40460, Shah Alam Selangor West Malaysia Tel: +603 5123 8888	Lot 16, Jalan Anggerik Vanilla 31/94 Seksyen 31, 40460 Shah Alam Selangor West Malaysia Tel: +603 5525 9758		No. 531 & 533, Jalan 11600, Penang West Malaysia Tel: +604 293 9883	No 1, Jalan Tiong Emas 1 Kawasan Perindustrian 81100 Johor Bahru, Johor West Malaysia Tel: +607 364 9989

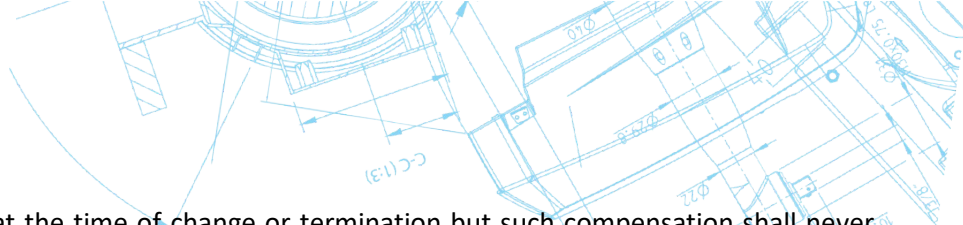

work-in-progress at the time of change or termination but such compensation shall never include loss of anticipated profits or any economic or consequential loss.

- 12.9 In the event that any term or provision of the Contract is declared null and void or unenforceable by any court of competent jurisdiction, the remainder of the provisions of the Contract shall remain in full force and effect to the fullest extent permitted by applicable law.
- 12.10 Headings in the Conditions are for convenience only and do not affect their interpretation.
- 12.11 References to all laws, regulations and codes of practice shall be deemed to include all amendments or revisions thereto and re-enactments thereof as may be made from time to time.
- 12.12 Unless expressly stated otherwise in these terms, an event of "Force Majeure" means any act of God, act of State, strike, lock-outs, government action, war, riot, acts of public enemy, transmission or systems failures, natural or man-made disasters or any other cause beyond a party's reasonable control. A party (the "Affected Party") will not be in breach of a Contract for a failure to perform to the extent the failure to perform is due to an event of Force Majeure and provided the Affected Party gives the other party prompt notice of the event of Force Majeure and acts reasonably to limit the impact of the event of Force Majeure.

Atlas Copco (Malaysia) Sdn. Bhd. 198201007501 (87259-U)

Head office	KL Hub Shared Finance	Branches	Penang	Johor
26, Jalan Anggerik Mokara 31/47, Seksyen 31 Kota Kemuning 40460, Shah Alam Selangor West Malaysia Tel: +603 5123 8888	Lot 16, Jalan Anggerik Vanilla 31/94 Seksyen 31, 40460 Shah Alam Selangor West Malaysia Tel: +603 5525 9758		No. 531 & 533, Jalan 11600, Penang West Malaysia Tel: +604 293 9883	No 1, Jalan Tiong Emas 1 Kawasan Perindustrian 81100 Johor Bahru, Johor West Malaysia Tel: +607 364 9989