



## Copyright notice

Any unauthorized use or copying of the contents or any part thereof is prohibited. This applies in particular to trademarks, model denominations, part numbers and drawings. This instruction book is valid for CE as well as non-CE labelled machines. It meets the requirements for instructions specified by the applicable European directives as identified in the Declaration of Conformity.

Published: 11/21/2023

## Trademark credit

©2023 Atlas Copco AB, Stockholm, Sweden.

## Disclaimer

The content of this manual may change from time to time without notice. We accept no liability for any errors that may appear in this manual nor do we make any expressed or implied warranties regarding the content. As far as practical we have ensured that the products have been designed and constructed to be safe and without risks when properly installed and used in accordance with their operating instructions.

We accept no liability for loss of profit, loss of market or any other indirect or consequential loss whatsoever.

Product warranty and limit of liability are dealt with in our standard terms and conditions of sale or negotiated contract under which this document is supplied.

You must use this product as described in this manual. Read the manual before you install, operate, or maintain the product.

# Contents

<b>1. Safety and compliance.</b>	<b>6</b>
1.1. Definition of Warnings and Cautions.	6
1.2. Trained personnel	6
1.3. Safety symbols.	7
<b>2. Important safety information.</b>	<b>8</b>
2.1. General precautions.	8
2.2. Safety precautions during installation	8
2.3. Safety precautions during operation.	10
2.4. Safety precautions during maintenance.	11
<b>3. Description.</b>	<b>13</b>
3.1. Vacuum and flow rate.	13
3.2. Design & Construction.	14
3.3. Intended use.	15
3.4. Misuse.	15
3.5. Pump components.	16
<b>4. Technical data.</b>	<b>19</b>
4.1. Pumping speed curve.	19
4.2. Dimension drawings.	22
4.3. Inlet dust filter (optional)	34
4.4. Performance data.	35
4.5. Mechanical data.	36
4.6. Lubrication data.	37
4.7. Oil specification.	37
4.8. Electrical data.	37
4.8.1. Electrical data for pump with three-phase motor.	38
<b>5. Installation.</b>	<b>39</b>
5.1. Installation Guidelines.	39
5.2. Unpacking and inspection of pump.	41
5.3. Pump handling and location.	41
5.4. Oil Filling.	41
5.5. Motor installation.	42
5.6. Electrical connections.	45
5.6.1. Motor configuration.	45
5.6.2. Power supply wiring for pump with three-phase motor.	46
5.6.3. Check the direction of pump rotation with three-phase motor.	47
5.7. Inlet connections.	47
5.8. Exhaust connections.	48

5.9. Leak check. . . . .	49
<b>6. Operation. . . . .</b>	<b>50</b>
6.1. Initial start-up preparation. . . . .	50
6.2. Start-up procedure. . . . .	51
6.3. Pumping of condensable vapours. . . . .	51
6.4. Oil decontamination. . . . .	51
6.5. During operation. . . . .	52
6.6. Stop the pump. . . . .	52
6.7. Taking out of operation. . . . .	52
<b>7. Maintenance. . . . .</b>	<b>53</b>
7.1. Maintenance plan. . . . .	53
7.2. Oil-level check. . . . .	54
7.3. Checking the oil condition. . . . .	55
7.4. Replacement of Oil. . . . .	55
7.5. Replacement of oil filter. . . . .	55
7.6. Exhaust filter replacement . . . . .	56
7.7. Cleaning instruction. . . . .	56
7.7.1. Clean the inlet-filter. . . . .	56
7.7.2. Anti suck-back valve cleaning. . . . .	56
7.7.3. Clean the gas-ballast valve. . . . .	57
7.7.4. Clean the oil-level sight-glass. . . . .	57
7.7.5. Cleaning. . . . .	57
7.7.6. Clean the oil return line of exhaust mist filter. . . . .	58
7.7.7. Clean and overhaul the pump. . . . .	58
7.7.8. Replacing vanes. . . . .	58
7.7.9. Test the motor condition. . . . .	59
<b>8. Storage. . . . .</b>	<b>60</b>
<b>9. Disposal. . . . .</b>	<b>61</b>
<b>10. Fault finding. . . . .</b>	<b>62</b>
<b>11. Service. . . . .</b>	<b>67</b>
11.1. Return the equipment or components for service . . . . .	67
11.2. Service kits. . . . .	67

## List of Figures

Figure 1: Vacuum and flow rate. . . . .	13
Figure 2: GVS 16 R and GVS 40 R. . . . .	16
Figure 3: GVS 65 R and GVS 100 R. . . . .	17
Figure 4: GVS 200 R and GVS 300 R. . . . .	18
Figure 5: Pumping speed curve - GVS 16 R. . . . .	19
Figure 6: Pumping speed curve - GVS 40 R. . . . .	19
Figure 7: Pumping speed curve - GVS 65 R. . . . .	20
Figure 8: Pumping speed curve - GVS 100 R. . . . .	20
Figure 9: Pumping speed curve - GVS 200 R. . . . .	21
Figure 10: Pumping speed curve - GVS 300 R. . . . .	21
Figure 11: Dimension drawing - GVS 16 R. . . . .	22
Figure 12: Dimension drawing bare shaft - GVS 16 R. . . . .	23
Figure 13: Dimension drawing - GVS 40 R. . . . .	24
Figure 14: Dimension drawing bare shaft - GVS 40 R. . . . .	25
Figure 15: Dimension drawing - GVS 65 R. . . . .	26
Figure 16: Dimension drawing bare shaft - GVS 65 R. . . . .	27
Figure 17: Dimension drawing - GVS 100 R. . . . .	28
Figure 18: Dimension drawing bare shaft - GVS 100 R. . . . .	29
Figure 19: Dimension drawing - GVS 200 R. . . . .	30
Figure 20: Dimension drawing bare shaft - GVS 200 R. . . . .	31
Figure 21: Dimension drawing - GVS 300 R. . . . .	32
Figure 22: Dimension drawing bare shaft - GVS 300 R. . . . .	33
Figure 23: Dimension drawing - Inlet dust filter (optional). . . . .	34
Figure 24: Oil level. . . . .	41
Figure 25: Pump and Motor coupling alignment. . . . .	42
Figure 26: GVS 16 R and GVS 40 R Motor installation. . . . .	43
Figure 27: GVS 65 R and GVS 100 R Motor installation. . . . .	44
Figure 28: GVS 200 R and GVS 300 R Motor installation. . . . .	45
Figure 29: Electrical connections three phase motor. . . . .	47
Figure 30: Oil level. . . . .	54

## 1. Safety and compliance

For safe operation from the start, read these instructions carefully before you install or commission the equipment and keep them safe for future use. Read all the safety instructions in this section and the rest of this manual carefully and make sure that you obey these instructions.

The instruction manual is an important safety document that we often deliver digitally. It is your responsibility to keep the instruction manual available and visible while working with the equipment. Please download the digital version of the instruction manual for use on your device or print it if a device will not be available.

### 1.1. Definition of Warnings and Cautions

Important safety information is highlighted as warning and caution instructions which are defined as follows. Different symbols are used according to the type of hazard.

---

#### **WARNING:**

If you do not obey a warning, there is a risk of injury or death.

---

---

#### **CAUTION:**

If you do not obey a caution, there is a risk of minor injury, damage to equipment, related equipment or process.

---

---

#### **NOTICE:**

Information about properties or instructions for an action which, if ignored, will cause damage to the equipment.

---

We reserve the right to change the design and the stated data. The illustrations are not binding.

### 1.2. Trained personnel











For the operation of this equipment “trained personnel” are:

- skilled workers with knowledge in the fields of mechanics, electrical engineering, pollution abatement and vacuum technology and
- personnel specially trained for the operation of vacuum pumps

## 1.3. Safety symbols

The safety symbols on the products show the areas where care and attention is necessary.

The safety symbols that we use on the product or in the product documentation have the following meanings:

	<p><b>Warning/Caution</b></p> <p>Risk of injury and/or damage to equipment. An appropriate safety instruction must be followed or a potential hazard exists.</p>
	<p><b>Warning - Dangerous voltage</b></p> <p>Risk of injury. Identifies possible sources of hazardous electrical shock.</p>
	<p><b>Warning - Hot surfaces</b></p> <p>Risk of injury. Identifies a surface capable of inflicting burns through contact.</p>
	<p><b>Warning - Overpressure</b></p> <p>Risk of increased pressure beyond permissible limit.</p>
	<p><b>Warning - Pressurised</b></p> <p>Risk of injury or damage to equipment. Identifies equipment containing pressurised gases or liquids.</p>
	<p><b>Warning - Risk of explosion</b></p> <p>Risk of injury or damage to equipment. Identifies a situation that could result in an explosion.</p>
	<p><b>Mandatory action symbol</b></p> <p>Failure to comply with this action may result in injury or damage to equipment.</p>
	<p><b>Mandatory - Read the manual</b></p> <p>Failure to comply with this action may result in injury or damage to equipment.</p>
	<p><b>Warning - Use protective equipment</b></p> <p>Risk of injury. Use appropriate Personal Protective Equipment (PPE) when performing the task.</p>
	<p><b>Warning - Wear protective respirator</b></p> <p>Risk of injury. Wear an appropriate protective respirator when performing the task.</p>

## 2. Important safety information

### 2.1. General precautions

- The operator must employ safe working practises and observe all related work safety requirements and regulations.
- If any of the following statements does not comply with the applicable legislation, the stricter of the two shall apply.
- Installation, operation, maintenance and repair work must only be performed by authorised, trained and specialised personnel.
- The vacuum pump is designed for handling atmospheric air only. No other gases, vapours or fumes should be exposed to the vacuum pump intake or processed by the vacuum pump.
- Before any maintenance, repair work, adjustment or any other non-routine checks, stop the vacuum pump, press the emergency stop button, switch off the voltage and make sure that the pump system is at atmospheric pressure level. In addition, the power isolating switch must be opened and locked.
- Prevent contact with pump inlet during operation.
- The owner is responsible for maintaining the unit in a safe operating condition. Parts and accessories shall be replaced if unsuitable for safe operation.
- Do not walk or stand on the unit or its components.

### 2.2. Safety precautions during installation

- Make sure that the pump is suitable for your application. If you have any doubt as to the suitability of the pump for your application, please contact the pump supplier group for further advice.
- Specific safety precautions are given at the appropriate point in the instructions. Please obey these safety instructions when you install the pump, especially when you connect the pump into an existing system. Make sure the whole system is safe when installing the pump and starting it.
- The machine must only be lifted using suitable equipment in accordance with the applicable safety regulations. Loose or pivoting parts must be securely fastened before lifting. It is strictly forbidden to dwell or stay in the risk zone under a lifted load. Lifting acceleration and deceleration must be kept within safe limits. Wear a safety helmet when working in the area of overhead of lifting equipment.
- The unit is designed for indoor use. If the unit is installed outdoors, special precautions must be taken; consult your supplier
- Place the machine where the ambient air is as cool and clean as possible. If necessary, install a suction duct. Never obstruct the air inlet. Water handling capacity is limited.
- Any blanking flanges, plugs, caps and desiccant bags must be removed before connecting the pipes.
- Air hoses must be of correct size and suitable for the working pressure. Never use frayed, damaged or worn hoses. Distribution pipes and connections must be of the correct size and suitable for the working pressure.



- The aspirated air must be free of flammable fumes, vapours and particles. (For example, paint solvents that can lead to internal fire or explosion).
- Arrange the air intake so that loose clothing worn by people cannot be sucked in.
- No external force may be exerted on the inlet and outlet connections; the connected pipes must be free of strain.
- If remote control is installed, the machine must bear a clear sign stating, "This machine is remotely controlled and may start without warning".
- The operator has to make sure that the machine is stopped depressurised, and that the electrical isolating switch is open, locked and labelled with a temporary warning before any maintenance or repair. As a further safeguard, persons switching remotely controlled machines shall take adequate precautions to make sure that there is no one checking or working on the machine. To this end, a suitable notice shall be affixed to the start equipment.
- Air-cooled machines must be installed in such a way that an adequate flow of cooling air is available and that the exhausted air does not recirculate to the inlet.
- The electrical connections must correspond to the applicable codes. The machines must be earthed and protected against short circuits by fuses in all phases. A lockable power isolating switch must be installed near the pump.
- On machines with automatic start/stop system or if the automatic restart function after voltage failure is activated, a sign stating "This machine may start without warning" must be affixed near the instrument panel.
- In multiple vacuum pump systems, manual valves must be installed to isolate each pump. Non-return valves (check valves) must not be relied upon for isolating multiple systems.
- Never remove or tamper with the safety devices, guards or insulation fitted on the machine.
- Piping or other parts with a temperature in excess of 70 °C (158 °F) and which may be accidentally touched by personnel in normal operation must be guarded or insulated. Other high temperature piping must be clearly marked.
- For water-cooled machines, the cooling water system installed outside the machine has to be protected by a safety device with set pressure according to the maximum cooling water inlet pressure.
- If the ground is not level or can be subject to variable inclination, consult the manufacturer.
- Pump outlet air contains traces of oil mist. Make sure compatibility with the working environment.
- Whenever air containing hazardous substances is sucked in (for example, biological or microbiological agents), use abatement systems placed upstream of the vacuum pump.
- Any vacuum pump placed in an application with inlet gas stream temperatures above the published maximum temperature should be approved by us prior to start-up.

**Note:**

Also consult [Safety precautions during operation](#) on page 10 and [Safety precautions during maintenance](#) on page 11.

*These precautions apply to machinery processing or consuming air or inert gas. Processing of any other gas requires additional safety precautions typical to the application which are not included herein.*

*Some precautions are general and cover several machine types and equipment; hence some statements may not apply to your machine.*

## 2.3. Safety precautions during operation

- Never touch any piping or components of the vacuum pump during operation.
- Use only the correct type and size of hose end fittings and connections. Make sure that a hose is fully depressurized before disconnecting it.
- Persons switching on remotely controlled machines shall take adequate precautions to ensure that there is no one checking or working on the machine. To this end, a suitable notice shall be affixed to the remote start equipment.
- Never operate the machine when there is a possibility of taking in flammable or toxic fumes, vapours or particles.
- Never operate the machine below or in excess of its limit ratings.
- Keep all bodywork doors shut during operation. The doors may be opened for short periods only, e.g. to carry out routine checks. Wear ear protectors when opening a door.
- On vacuum pumps without bodywork, wear ear protection in the vicinity of the machine.
- People staying in environments or rooms where the sound pressure level reaches or exceeds 80 dB(A) shall wear ear protectors.
- Periodically check that:
  - All guards are in place and securely fastened
  - All hoses and/or pipes inside the machine are in good condition, secure and not rubbing
  - There are no leaks
  - All fasteners are tight
  - All electrical leads are secure and in good order
  - Safety valves and other pressure relief devices are not obstructed by dirt or paint
  - Air outlet valve and air net, i.e. pipes, couplings, manifolds, valves, hoses etc. are in good repair, free of wear or abuse
  - Electrical cabinet air cooling filters are not clogged
- If warm cooling air from vacuum pumps is used in air heating systems, for example, to warm up a workroom, take precautions against air pollution and possible contamination of the breathing air.
- On water-cooled vacuum pumps using open circuit cooling towers, protective measures must be taken to avoid the growth of harmful bacteria such as Legionella pneumophila bacteria.

- Do not remove any of, or tamper with, the sound-damping material.
- Never remove or tamper with the safety devices, guards or insulations fitted on the machine.
- The oil separator tank can be slightly pressurized. Do not open and do not leave oil filler or drain plugs open during operation.
- Do not use the pump as a compressor.
- Never run the pump without the air intake filter mounted.

 **Note:**

*These precautions apply to machinery processing or consuming air or inert gas. Processing of any other gas requires additional safety precautions typical to the application which are not included herein.*

*Some precautions are general and cover several machine types and equipment; hence some statements may not apply to your machine.*

## 2.4. Safety precautions during maintenance

- A suitably trained and supervised technician must maintain the pump. Obey your local and national safety requirements.
- Use only the correct tools for maintenance and repair work.
- Make sure that the maintenance technician is familiar with the safety procedures which relate to the pump-oil and the products processed by the pumping system.
- Check that all the required parts are available and of the correct type before you start work.
- Isolate the pump and other components from the electrical supply so that they cannot be operated accidentally.
- Allow the pump to cool (so that it is at a safe temperature for skin contact) before you start maintenance work. Make sure the pump is switched OFF in case the thermal overload device restarts the pump.
- Make sure the pump is switched OFF. Do not reuse O-rings and seals.
- After maintenance is completed, recheck the direction of pump rotation if the electrical supply has been disconnected.
- If the pump and the pump-oil is contaminated with the process chemicals that have been pumped during operation. Make sure that the pump is decontaminated before maintenance and that you take adequate precautions to protect people from the effects of dangerous substances if contamination has occurred.
- Maintain the motor as specified in the manufacturer's information supplied with the motor.
- Before removing any component, effectively isolate the machine from all sources of underpressure and/or overpressure and make sure that the pump system is at atmospheric pressure level.
- Never use flammable solvents or carbon tetrachloride for cleaning parts. Take safety precautions against toxic vapours of cleaning liquids.

- Scrupulously observe cleanliness during maintenance and repair. Keep dirt away by covering the parts and exposed openings with a clean cloth, paper or tape.
- Never weld or perform any operation involving heat near the oil system. Oil tanks must be completely purged, for example, by steam cleaning, before carrying out such operations. Never weld on, or in any way modify, pressure vessels.
- Never use caustic solvents which can damage materials of the air net, (for example, polycarbonate bowls).
- Faults or wearing of seals may cause oil lubricant leaks. Avoid dispersion in soil and pollution of other materials.
- Never use a light source with open flame for inspecting the interior of a machine, pressure vessel, etc.
- Make sure that no tools, loose parts or rags are left in or on the machine.
- All regulating and safety devices shall be maintained with due care to ensure that they function properly. They may not be put out of action.

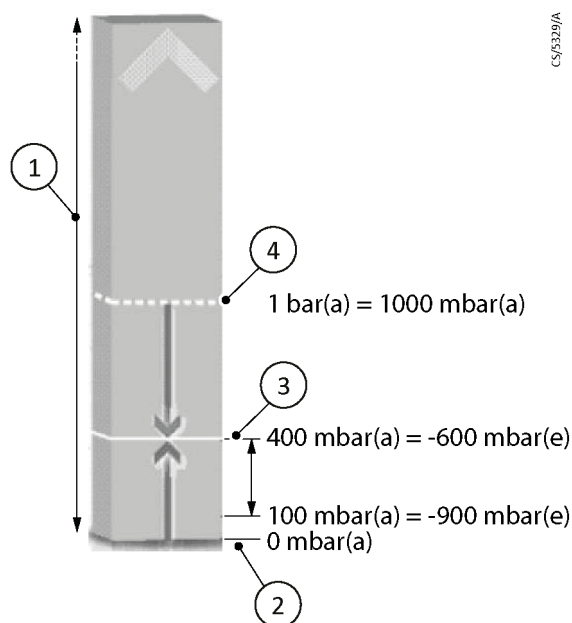
### 3. Description

#### 3.1. Vacuum and flow rate

A vacuum is any pressure in a system that is below the ambient atmospheric pressure. It can be denoted in absolute terms or in effective (gauge) terms:

- Absolute pressure mbar(a) - Denotes how much the pressure is above absolute zero pressure (perfect vacuum).
- Effective or gauge pressure mbar(e) - Denotes how much the pressure is below the local atmospheric pressure.

**Figure 1** Vacuum and flow rate



- |                                      |                         |
|--------------------------------------|-------------------------|
| 1. Pressure                          | 2. Absolute vacuum      |
| 3. Typical application working range | 4. Atmospheric pressure |

Atmospheric pressure at sea level is roughly 1 bar(a) or 1000 mbar(a) or 0 bar(e). The typical working range for pump applications is 400 mbar(a) to 100 mbar(a), for example -600 mbar(e) to -900 mbar(e). This operating pressure range is just indicative. The GVS R vacuum pumps are designed for continuous operation between atmospheric pressure and their ultimate pressure.

It is important to understand which type of reference is required before selecting a pressure instrument for measuring the vacuum. It must be noted that the distinction doesn't matter for a pressure difference ( $\Delta P$ ; for example, pressure loss), since it is always the result of subtracting 2 pressures (whether stated as absolute or effective pressures).

#### Flow rate definitions

There are 2 common but different ways to denote flow rate in vacuum.

1. Based on the displacement or volumetric flow rate.

2. Based on the throughput or mass flow rate.

The vacuum pumps use volumetric flow rate to denote performance, the unit being actual  $\text{m}^3/\text{h}$ .

### Displacement or volumetric flow rate

Over the relevant pressure range, a GVS R pump operates at constant motor speed (rotations per minute) and since the compression chambers have fixed dimensions, the same volume of air is pumped from inlet to outlet with falling pressure level. Over the relevant pressure range, this makes the volumetric flow rate practically independent of the vacuum level. It is the expression of the flow rate inside the piping at the governing vacuum level (actual  $\text{m}^3/\text{h}$ ) and is always higher than the standard flow rate ( $\text{Nm}^3/\text{h}$ ).

### Standard flow rate

Although the volumetric flow rate remains practically constant with decreasing (absolute) pressure, the number of molecules in that pumped volume is not constant. By definition: deeper the vacuum, the lower the number of molecules in the same volume. This means that the mass flow will decrease with decreasing (absolute) pressure. A flow rate must be stated at a certain vacuum level when using this denotation.

## 3.2. Design & Construction

- The GVS R pumps are single-stage, oil-sealed and air-cooled rotary vane vacuum pumps driven by an electric motor. The pumps have been specifically designed to work with clean air, inert gas or small amounts of water vapour. The pump has an inlet port with, exhaust port and a gas ballast valve.
- A rotor with three vanes is positioned inside the pump cylinder and it is supported by means of two bearings. As the rotor rotates, the intake portion of the pumping chamber expands and allows gas to enter into the chamber through the inlet port. The gases passing through open anti-suck back valve, enters the pump chamber. As the rotor rotates further, the vane separates part of the pump chamber from the inlet port. This part of the pump chamber is reduced, and the gas is compressed. At slightly above atmospheric pressure, the gas is expelled from the chamber through the exhaust valve. This valve ejects a mixture of air and oil into the exhaust filter element. After passing the exhaust filter element, clean air - conditioned to a few parts per million is discharged through the exhaust port.
- Anti-suck back valve is built into the inlet port which is protected by a metal wire mesh strainer. During standstill of the pump (for example due to shutting down or a power failure) the valve closes the intake. This prevents the pressure from rising in the connected chamber while the pump is vented at the same time. Suck-back of pump oil into the vacuum system is thus also effectively prevented.
- To pump high vapour loads, gas-ballast is delivered into the pump, by opening the gas ballast valve; a controlled amount of air is admitted into the pump chamber. This gas ballast prevents condensation (up to the limit of water vapour tolerance specified in the [Technical data](#) on page 19) when pumping condensable gases or vapours.

- The oil level can be viewed through the oil level sight glass situated on the front of the oil tank. The provision for oil pouring and oil drain are provided on the oil tank respectively.
- The pumps have simple and reliable oil recirculating systems; the oil circulation in pump chamber for sealing, lubrication and cooling of the pump is recycled from the pumps oil reservoir. The oil carried with the process gas is roughly separated in the oil reservoir before the discharge gas enters the integrated Exhaust Mist Filter (EMF) where the fine oil mist is trapped. The separated oil is collected in the oil chamber and then supplied back to the pump.
- The pump is mounted on vibration isolators.
- The pumps are directly driven by electric motor through a flexible motor-coupling. All components including anti-suck back, exhaust mist filter, oil return line are made extremely compact considering the high efficiency of the pumps.

### 3.3. Intended use

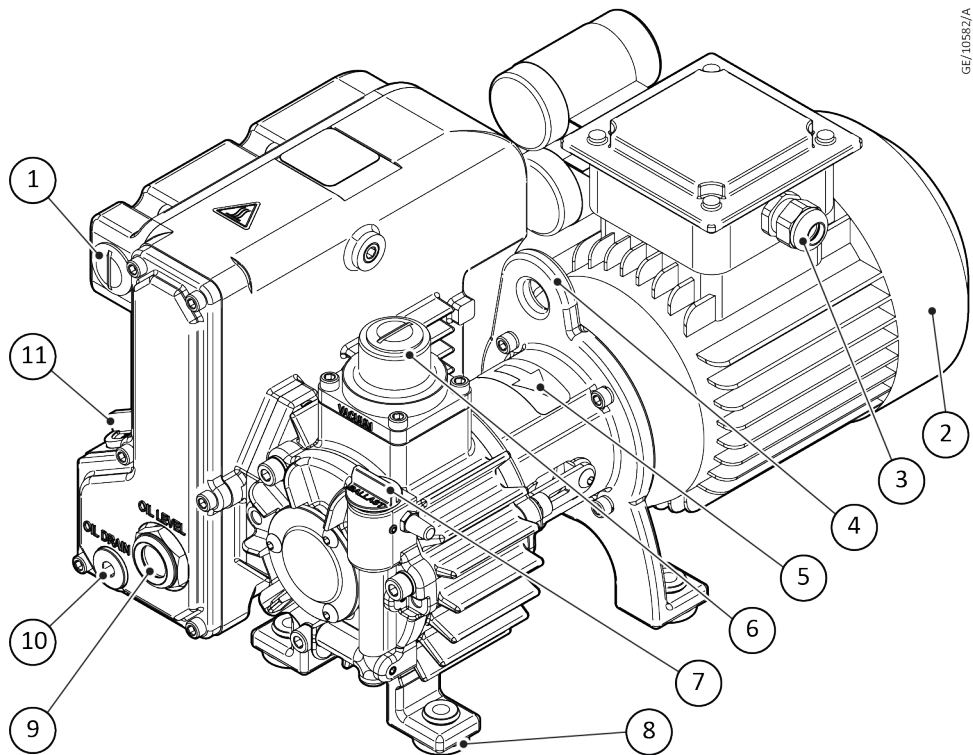
- The pumps are designed for pumping inert gases in the range of rough vacuum, between atmospheric pressure and ultimate pressure of the pump.

### 3.4. Misuse

- The pumps are not designed for pumping of aggressive, corrosive, flammable or explosive gases. If presence of aggressive, flammable, corrosive or explosive gases exist, contact us. These pumps are not designed for working in flammable or explosive environment.
- The pumps are not suitable for pumping liquids or media which contain dust. Corresponding protective measures must be introduced.
- The pumps are not designed for pumping oxygen (> 20 %) greater than atmospheric concentrations or other highly reactive gases.
- Contact us for more information.

### 3.5. Pump components

**Figure 2** GVS 16 R and GVS 40 R

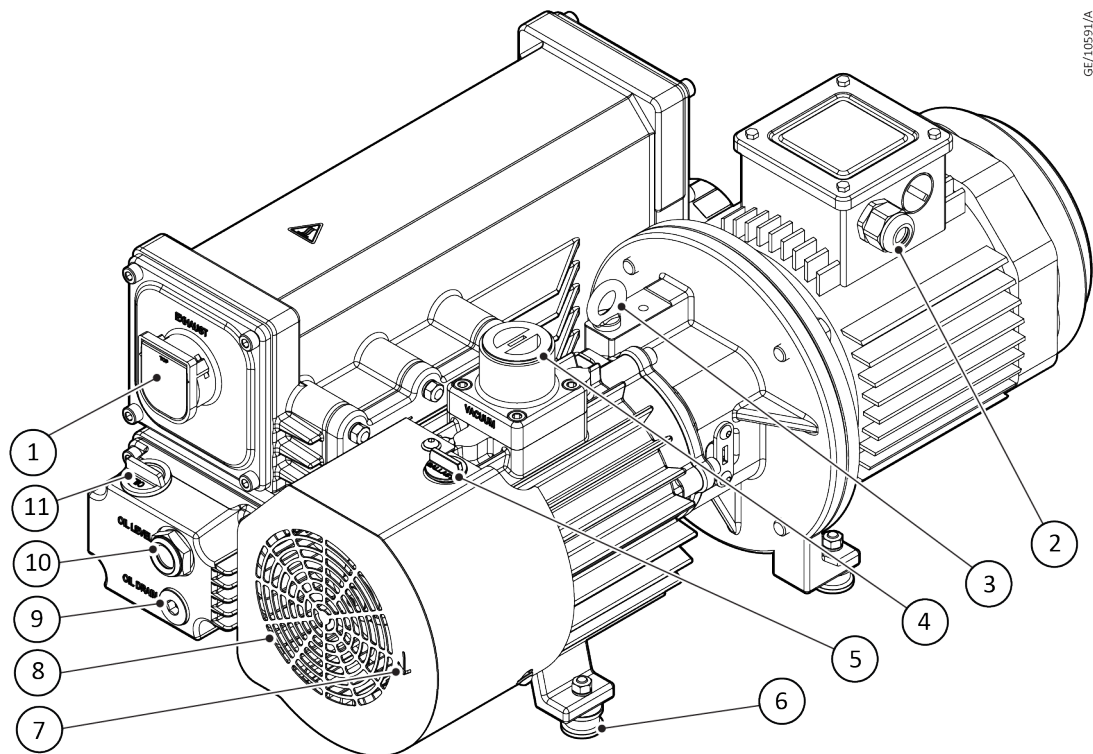


GE/10582/A

- |                           |   |
|---------------------------|---|
| 1. Exhaust port           | 2. Motor fan cover  |
| 3. Electrical cable entry | 4. Lifting eye  |
| 5. Direction of rotation  | 6. Inlet port   |
| 7. Gas ballast valve      | 8. Vibration isolators (x4 in GVS 16 R) and (x3 in GVS 40R) |
| 9. Oil level sight-glass  | 10. Oil drain plug  |
| 11. Oil pouring plug      |   |

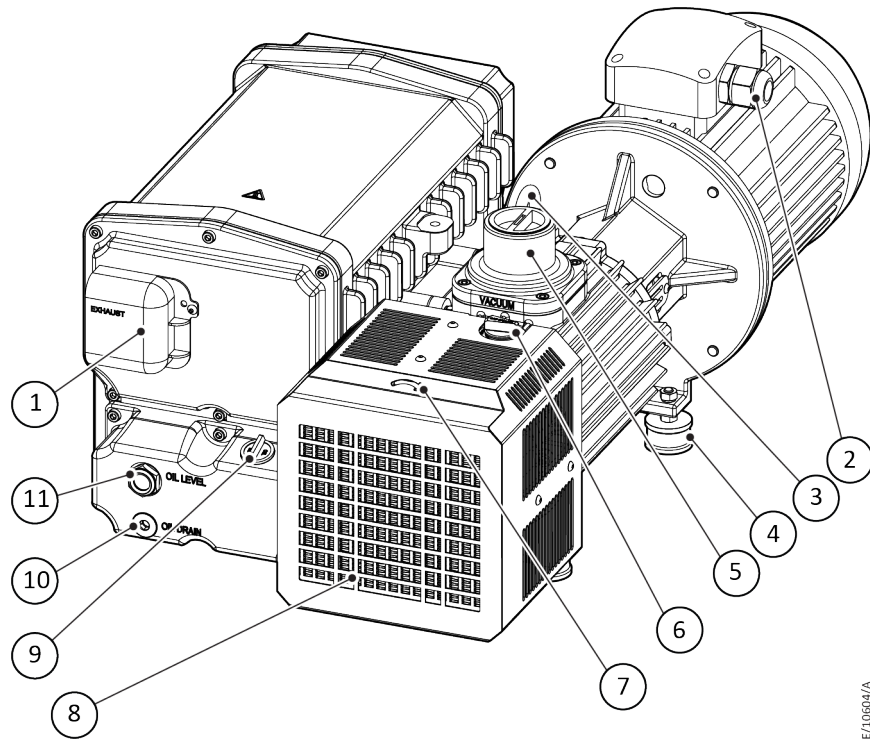


**Figure 3** GVS 65 R and GVS 100 R



- |                          |   |
|--------------------------|---|
| 1. Exhaust port          | 2. Electrical cable entry                                   |
| 3. Lifting eye           | 4. Inlet port   |
| 5. Gas ballast valve     | 6. Vibration isolators (x3 in GVS 65R) and (x4 in GVS 100R) |
| 7. Direction of rotation | 8. Pump fan-cover   |
| 9. Oil drain plug        | 10. Oil level sight-glass                                   |
| 11. Oil pouring plug     |   |

Figure 4 GVS 200 R and GVS 300 R



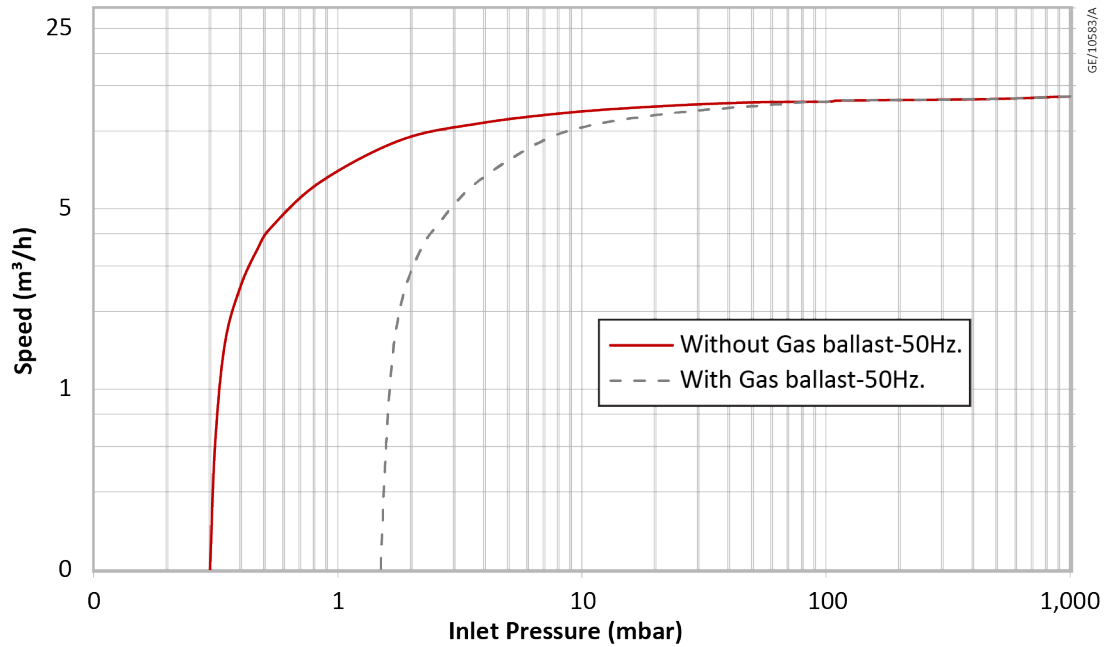
GE/106004/A

- |                           |                                   |
|---------------------------|-----------------------------------|
| 1. Exhaust port           | 2. Electrical cable entry         |
| 3. Lifting eye            | 4. Vibration isolator (x4)        |
| 5. Inlet port             | 6. Gas ballast valve              |
| 7. Direction of rotation  | 8. Grilled radiator and fan cover |
| 9. Oil pouring plug       | 10. Oil drain plug                |
| 11. Oil level sight-glass |                                   |

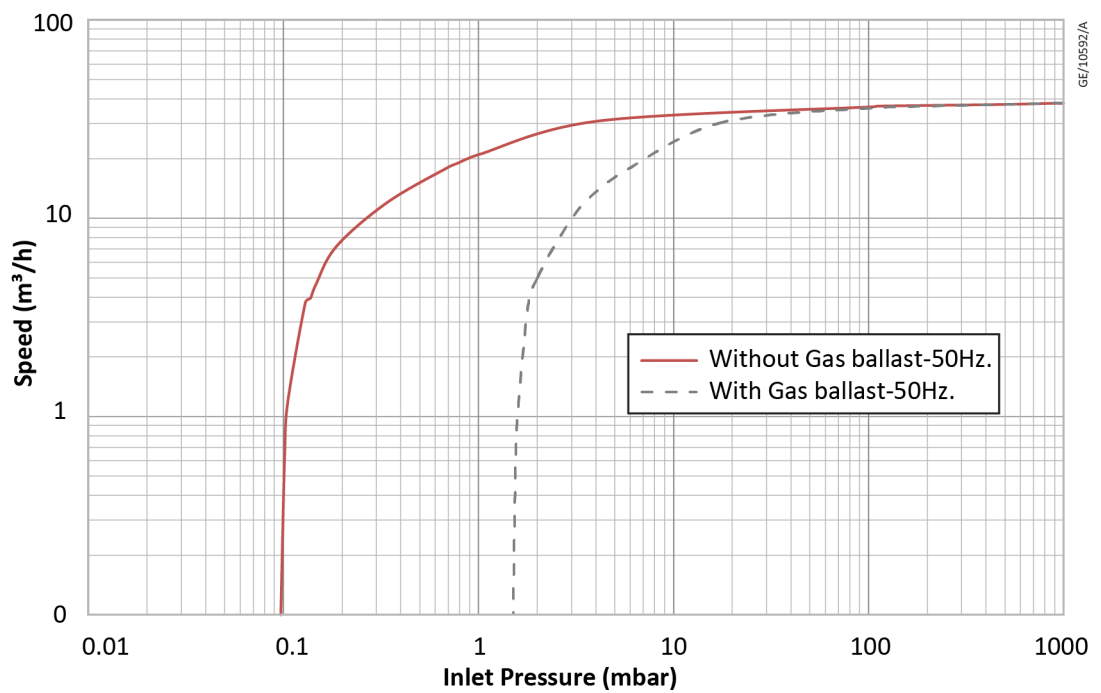
## 4. Technical data

### 4.1. Pumping speed curve

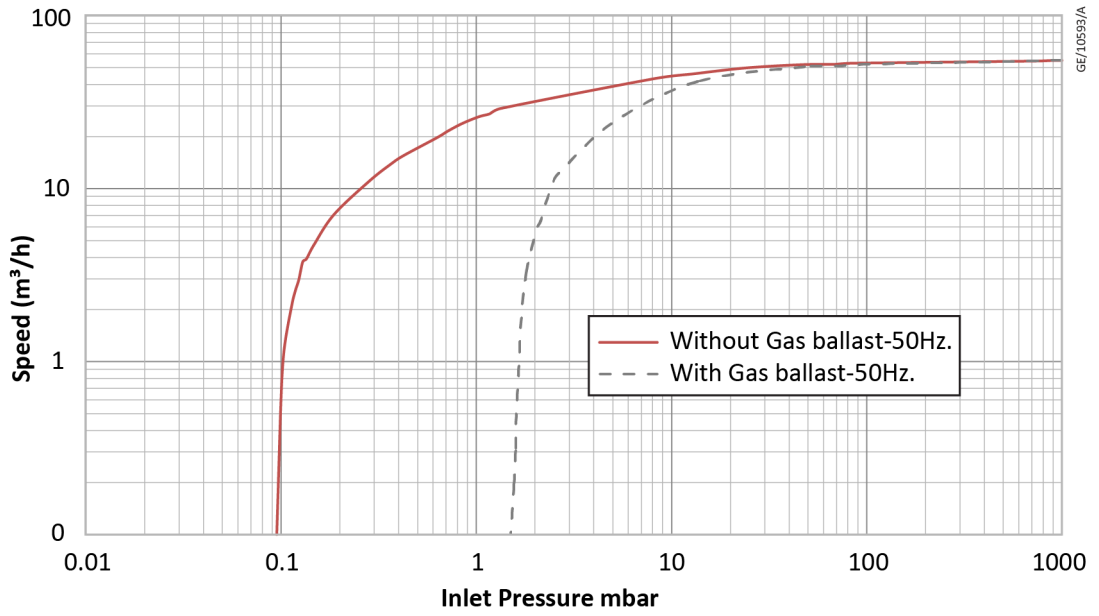
**Figure 5** Pumping speed curve - GVS 16 R



**Figure 6** Pumping speed curve - GVS 40 R



**Figure 7** Pumping speed curve - GVS 65 R



**Figure 8** Pumping speed curve - GVS 100 R

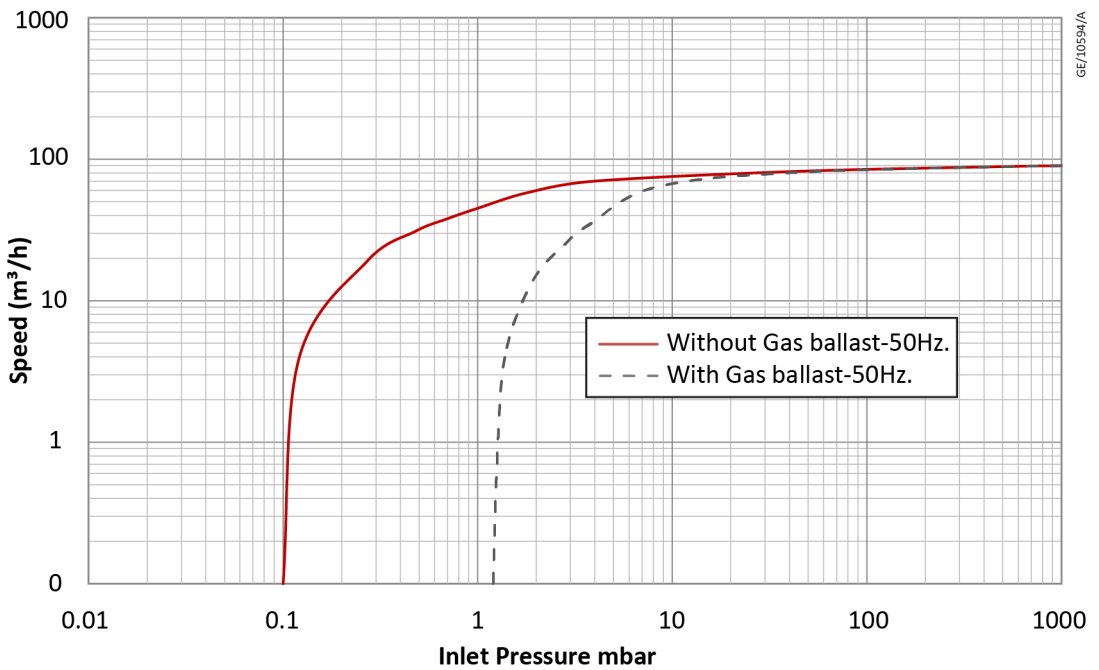


Figure 9 Pumping speed curve - GVS 200 R

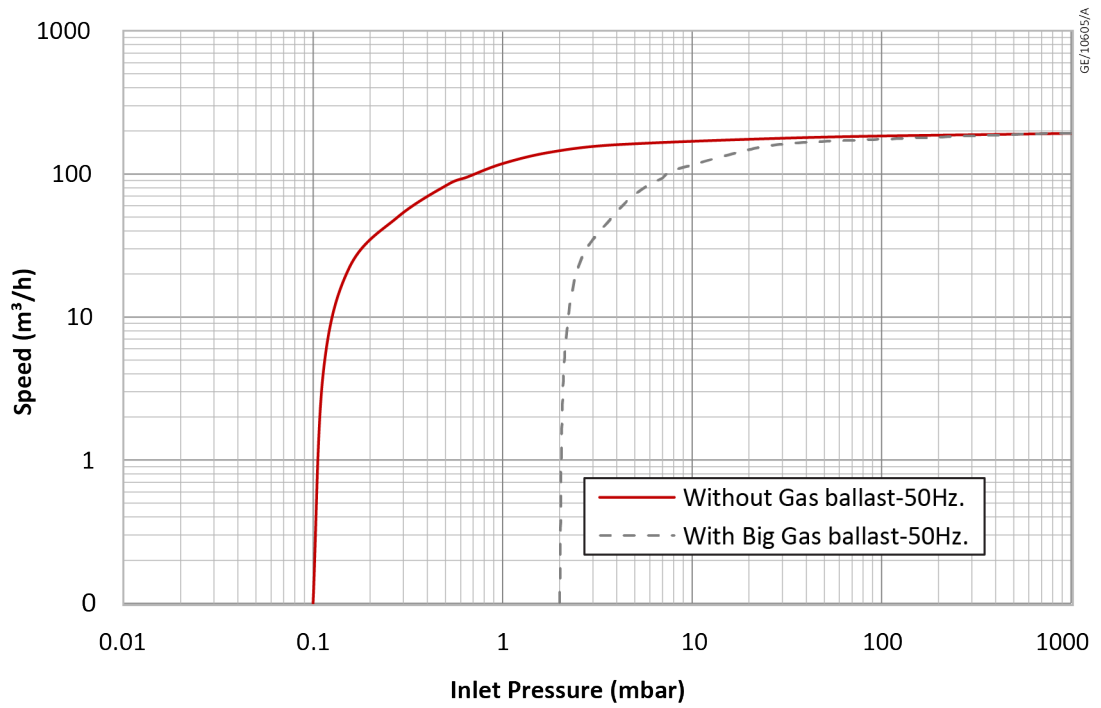
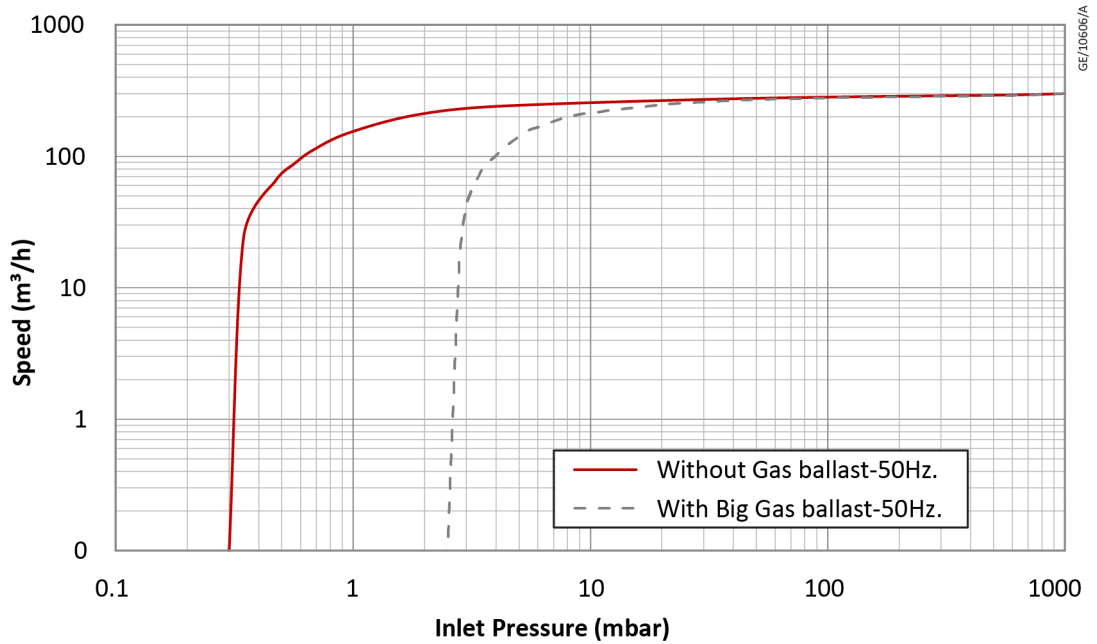
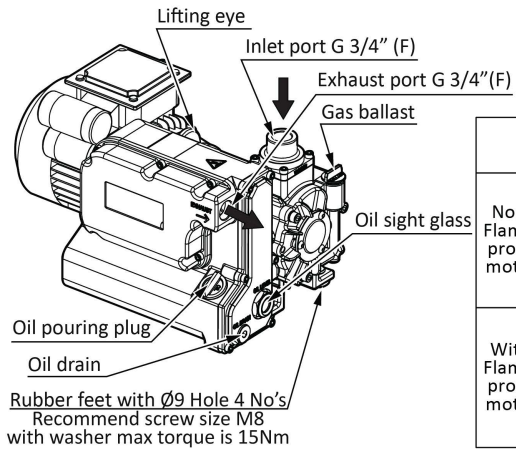
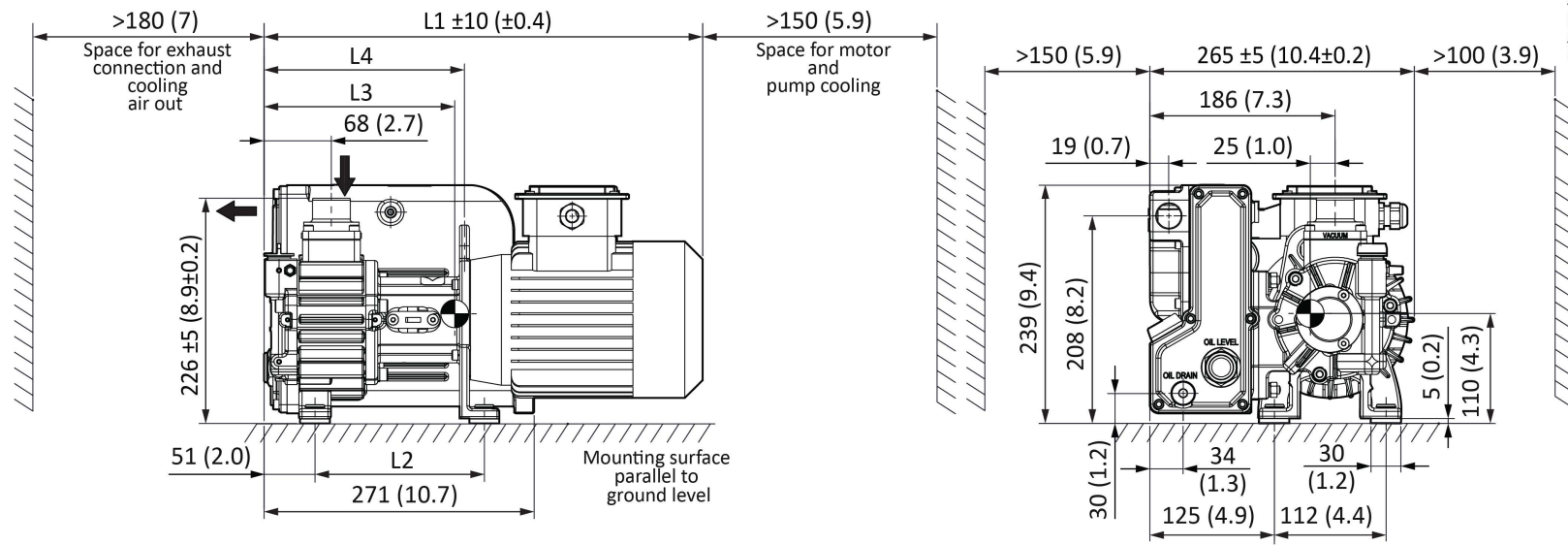


Figure 10 Pumping speed curve - GVS 300 R



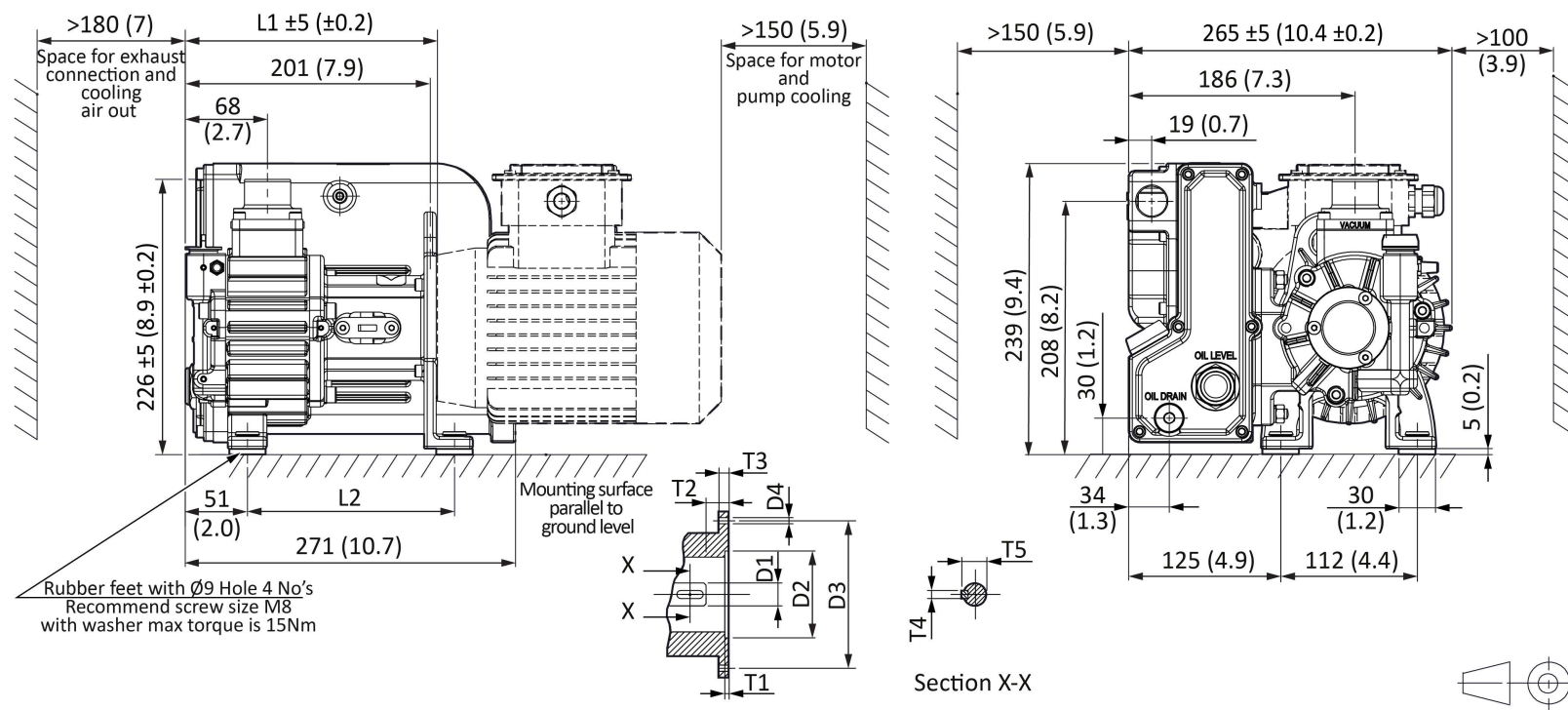
## 4.2. Dimension drawings

Figure 11 Dimension drawing - GVS 16 R



	Motor variant	Designation	L1 #	L2	L3	L4	Pump Approx. mass in kg. #	
							Without oil	With oil
Non Flame proof motor	3 Phase, 0.55 kW, 415V, 4 POLE, 50Hz, IE2	2031000000	440 [17.3]	170 [6.7]	191 [7.5]	201 [7.9]	29	30
	3 Phase, 0.55 kW, 415V, 4 POLE, 50Hz, IE3	2031000001						
	3 Phase, 0.75 kW, 415V, 4 POLE, 50Hz, IE2	2031000002						
	3 Phase, 0.75 kW, 415V, 4 POLE, 50Hz, IE3	2031000003						
With Flame proof motor	3 Phase, 0.55 kW, 415V, 4 POLE, 50Hz, IE2	2031000004	452 [17.8]	225 [8.8]		40	41	
	3 Phase, 0.55 kW, 415V, 4 POLE, 50Hz, IE3	2031000005						
	3 Phase, 0.75 kW, 415V, 4 POLE, 50Hz, IE2	2031000006						
	3 Phase, 0.75 kW, 415V, 4 POLE, 50Hz, IE3	2031000007						

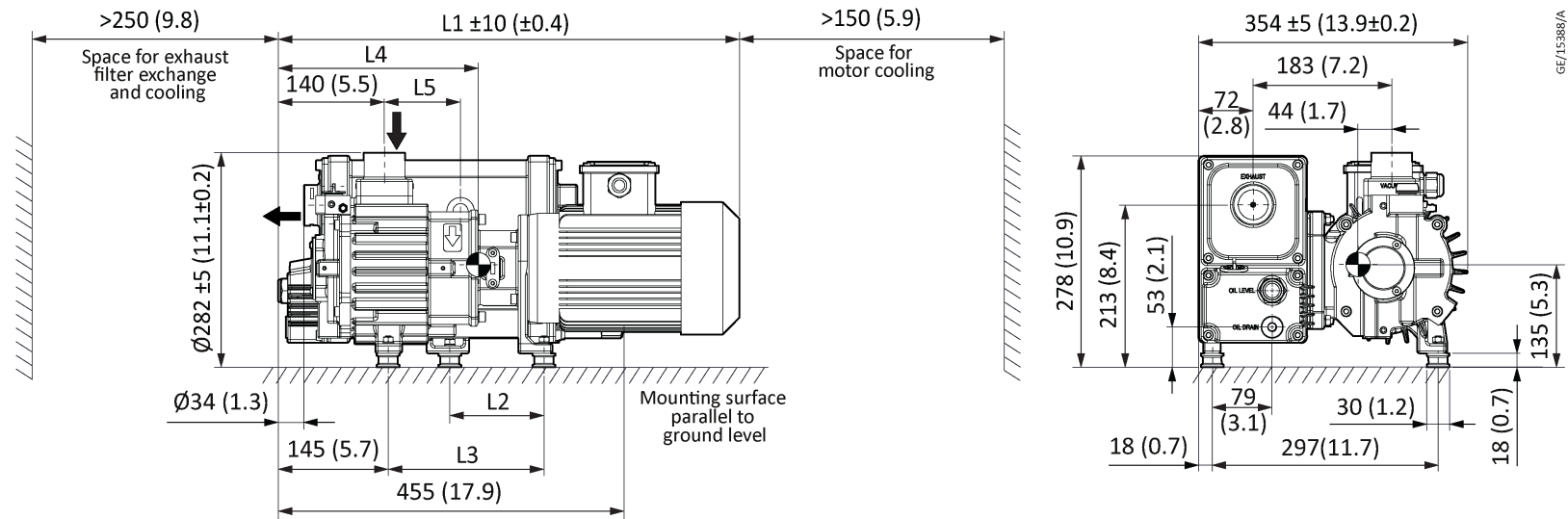
Figure 12 Dimension drawing bare shaft - GVS 16 R



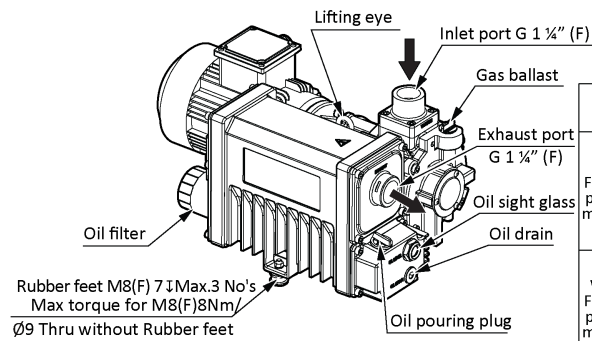
Pump Designation	Suitable for Motor	L1	L2	D1 h6	D2 +0.050 +0.025	D3	D4	T1	T2	T3	T4 h9	T5 +0.00 -0.15	Pump Approx. mass in kg.	
													Without oil	With oil
203100008	0.55 kW, 4 Pole, B14, 80 frame	207 [8.1]	170 [6.7]	∅ 16	∅ 80	∅ 100	∅ 7	4	53	10	5	17.2	17	18
	0.75 kW, 4 Pole, B14, 80 frame													

GE/13821/A

**Figure 13** Dimension drawing - GVS 40 R



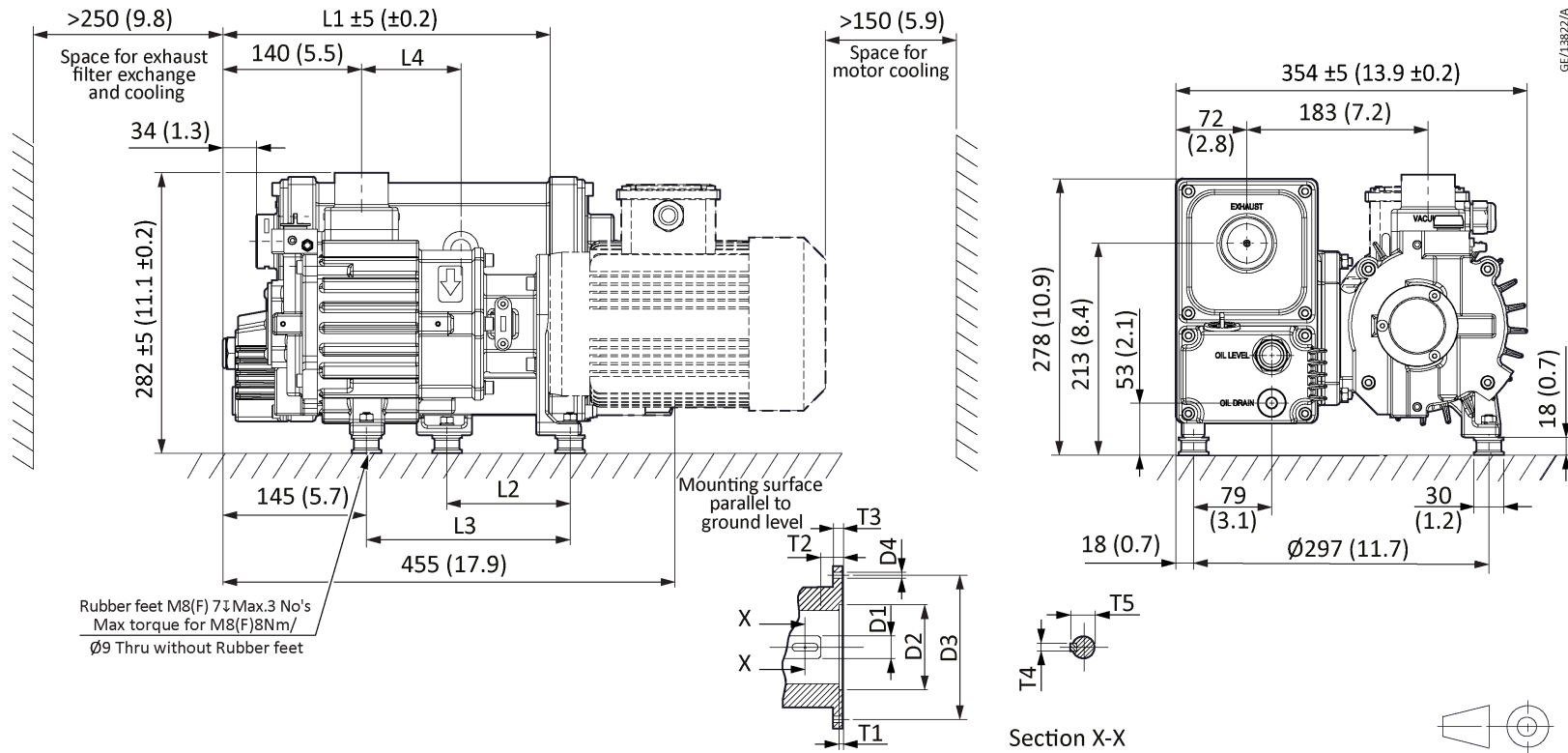
GE/15388/A



	Motor variant	Designation	L1 #	L2	L3	L4	L5	Pump Approx. mass in kg.#	
								Without oil	With oil
Non Flame proof motor	3 Phase, 1.1 kW, 415V, 6 POLE, 50Hz, IE2	2031001000	607 [23.9]	124 [4.9]	205 [8.1]	263 [10.4]	100 [3.9]	55	56.6
	3 Phase, 1.1 kW, 415V, 6 POLE, 50Hz, IE3	2031001001							
	3 Phase, 1.5 kW, 415V, 6 POLE, 50Hz, IE2	2031001002	632 [25]	136 [5.4]	217 [8.5]	305 [12]	149 [5.9]	57	58.6
	3 Phase, 1.5 kW, 415V, 6 POLE, 50Hz, IE3	2031001003							
With Flame proof motor	3 Phase, 1.1 kW, 415V, 6 POLE, 50Hz, IE2	2031001004	660 [26]	124 [4.9]	205 [8.1]	317 [12.5]	100 [3.9]	77	78.6
	3 Phase, 1.1 kW, 415V, 6 POLE, 50Hz, IE3	2031001005							
	3 Phase, 1.5 kW, 415V, 6 POLE, 50Hz, IE2	2031001006	697 [27.4]	136 [5.4]	217 [8.5]	347 [13.7]	149 [5.9]	88	89.6
	3 Phase, 1.5 kW, 415V, 6 POLE, 50Hz, IE3	2031001007							

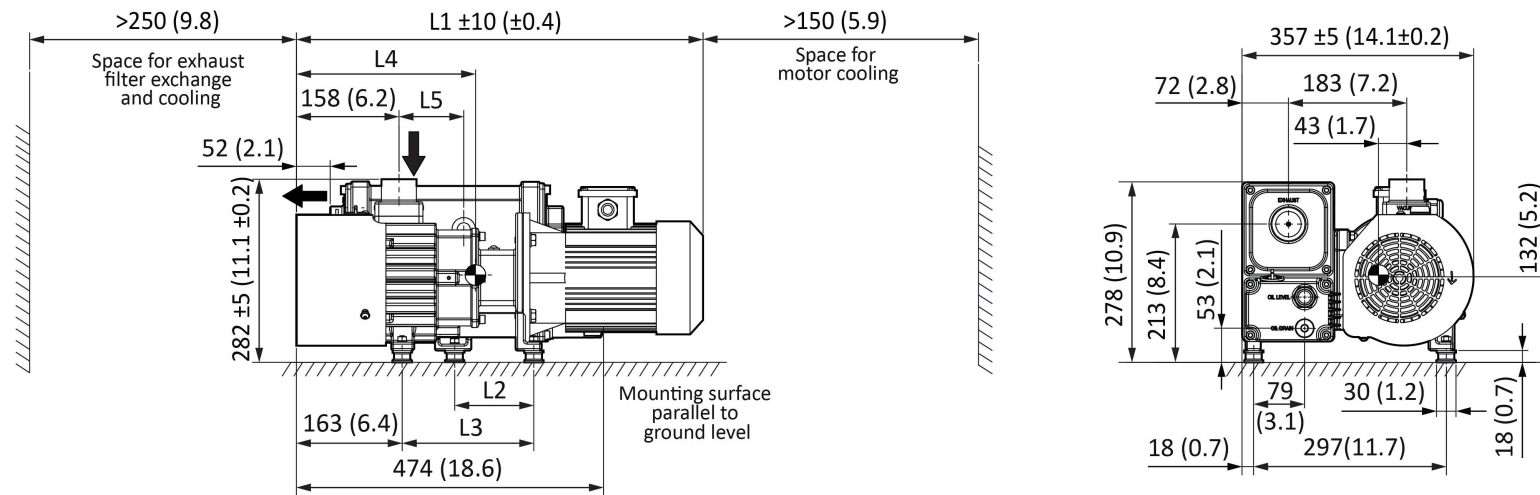


Figure 14 Dimension drawing bare shaft - GVS 40 R

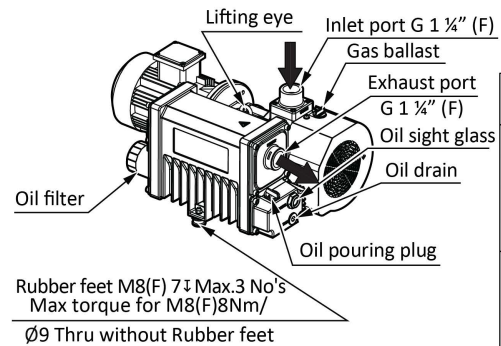


Pump Designation	Suitable for Motor	L1#	L2	L3	L4	D1 h6	D2 +0.050 +0.025	D3	D4	T1	T2	T3	T4 h9	T5 +0.00 -0.15	Pump Approx. mass in kg.	
															Without oil	With oil
2031001008	1.1 kW, 6 Pole, B14, 90L frame	330[13]	124[4.9]	205[8.1]	100[3.9]	Ø16	Ø95	Ø115	Ø9	4	63	14	5	17.2	38.4	40
2031001009	1.5 kW, 6 Pole, B14, 90L frame	342[13.5]	136[5.4]	217[8.5]	149[5.9]		Ø110	Ø130			75				39	40.6

**Figure 15** Dimension drawing - GVS 65 R

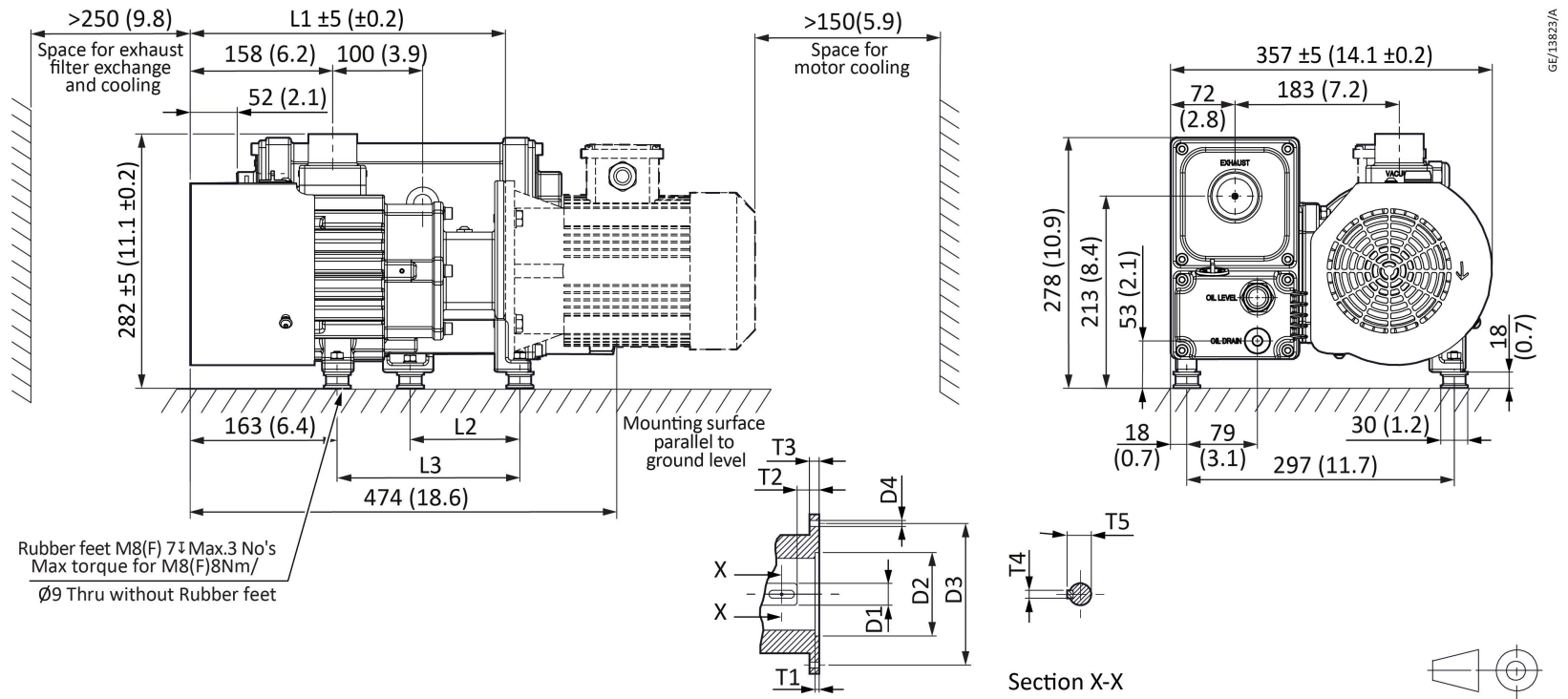


GE/15389/A



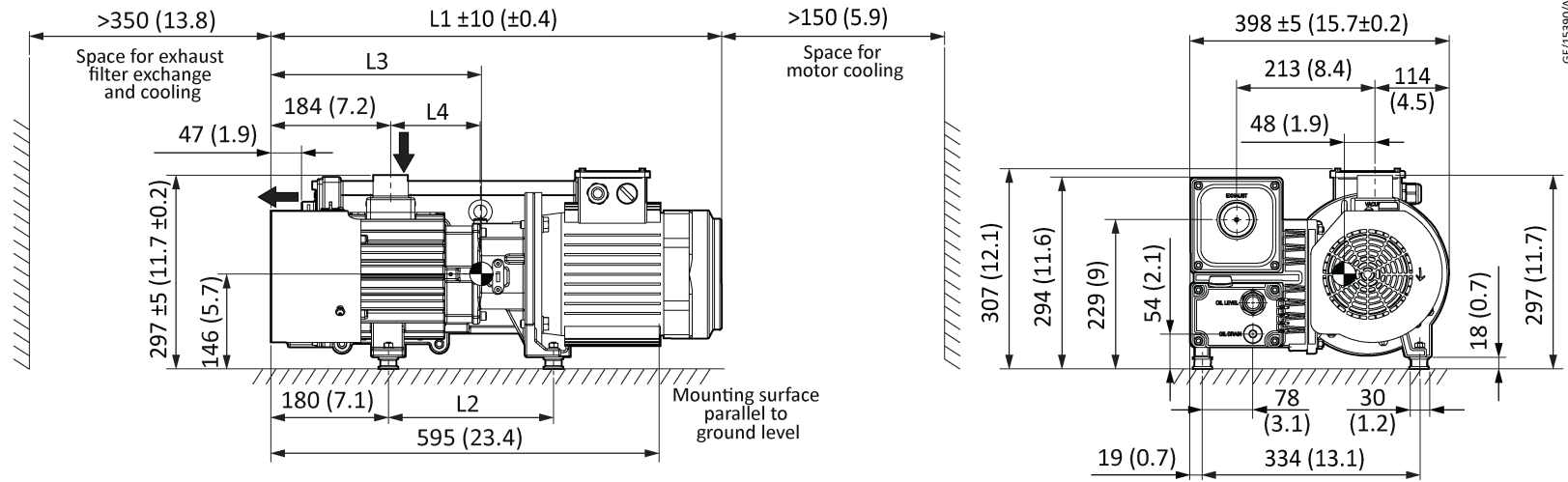
Motor variant	Designation	L1 #	L2	L3	L4	L5	Pump Approx. mass in kg. #		
							Without oil	With oil	
Non Flame proof motor	3 Phase, 1.5 kW, 415V, 4 POLE, 50Hz, IE2	2031002000	627 [24.7]	122 [4.8]	203 [8.0]	276 [10.9]	100 [3.9]	59	60.6
	3 Phase, 1.5 kW, 415V, 4 POLE, 50Hz, IE3	2031002001							
	3 Phase, 2.2 kW, 415V, 4 POLE, 50Hz, IE2	2031002002	666 [26.2]	136 [5.4]	217 [8.5]	318 [12.5]	150 [5.9]	64	65.6
	3 Phase, 2.2 kW, 415V, 4 POLE, 50Hz, IE3	2031002003							
With Flame proof motor	3 Phase, 1.5 kW, 415V, 4 POLE, 50Hz, IE2	2031002004	680 [26.8]	122 [4.8]	203 [8.0]	330 [13]	100 [3.9]	80	81.6
	3 Phase, 1.5 kW, 415V, 4 POLE, 50Hz, IE3	2031002005							
	3 Phase, 2.2 kW, 415V, 4 POLE, 50Hz, IE2	2031002006	715 [28.1]	136 [5.4]	217 [8.5]	360 [14.2]	150 [5.9]	90	91.6
	3 Phase, 2.2 kW, 415V, 4 POLE, 50Hz, IE3	2031002007							

Figure 16 Dimension drawing bare shaft - GVS 65 R

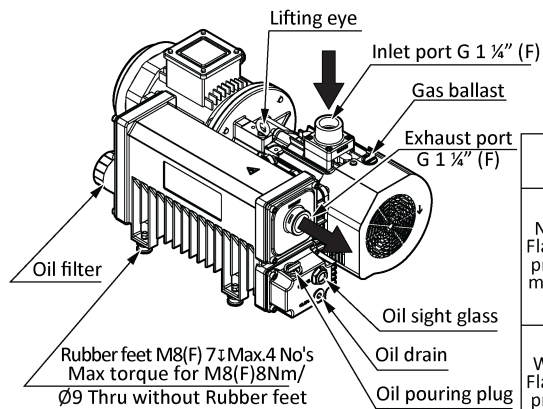


Pump Designation	Suitable for Motor	L1	L2	L3	D1 h6	D2 +0.050 +0.025	D3	D4	T1	T2	T3	T4 h9	T5 +0.0 -0.2	Pump Approx. mass in kg.	
														Without oil	With oil
2031002008	1.5 kW, 4 Pole, B5, 90L frame	350[13.8]	122[4.8]	203[8.0]	Ø22	Ø130	Ø165	M10	5	68	12	8	25	41.5	43.1
2031002009	2.2 kW, 4 Pole, B14, 100L frame	360[14.2]	136[5.4]	217[8.5]		Ø110	Ø130	Ø9	4	78	14			40.8	42.4

**Figure 17** Dimension drawing - GVS 100 R

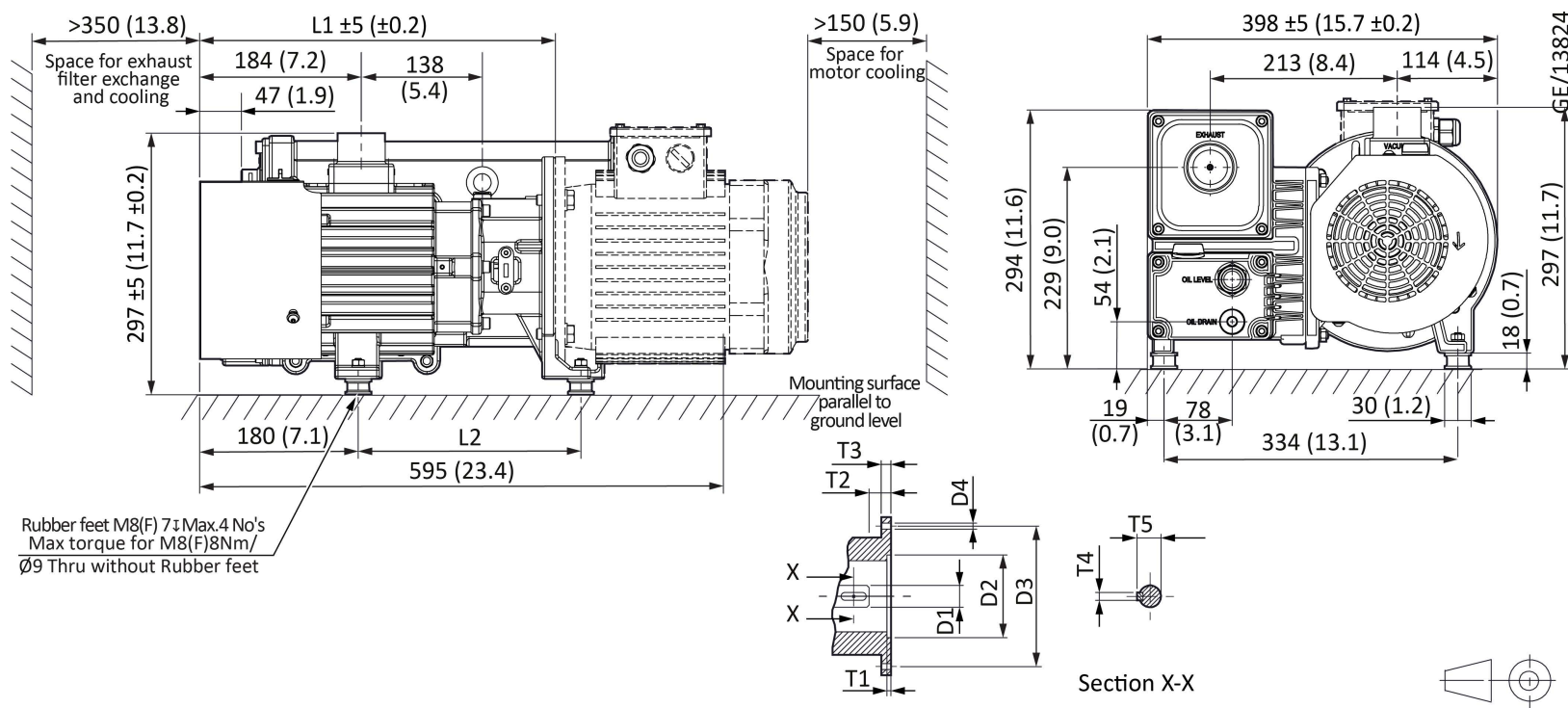


GE/115390/A



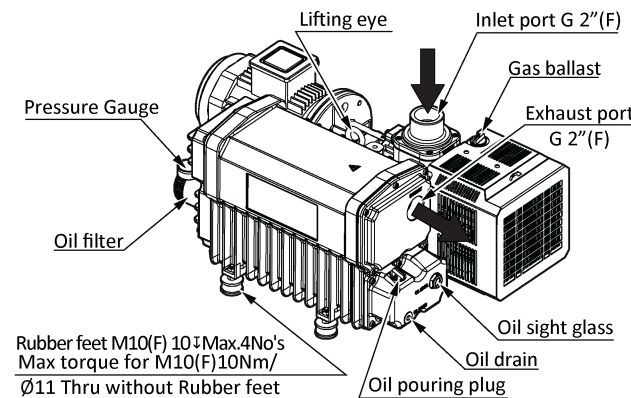
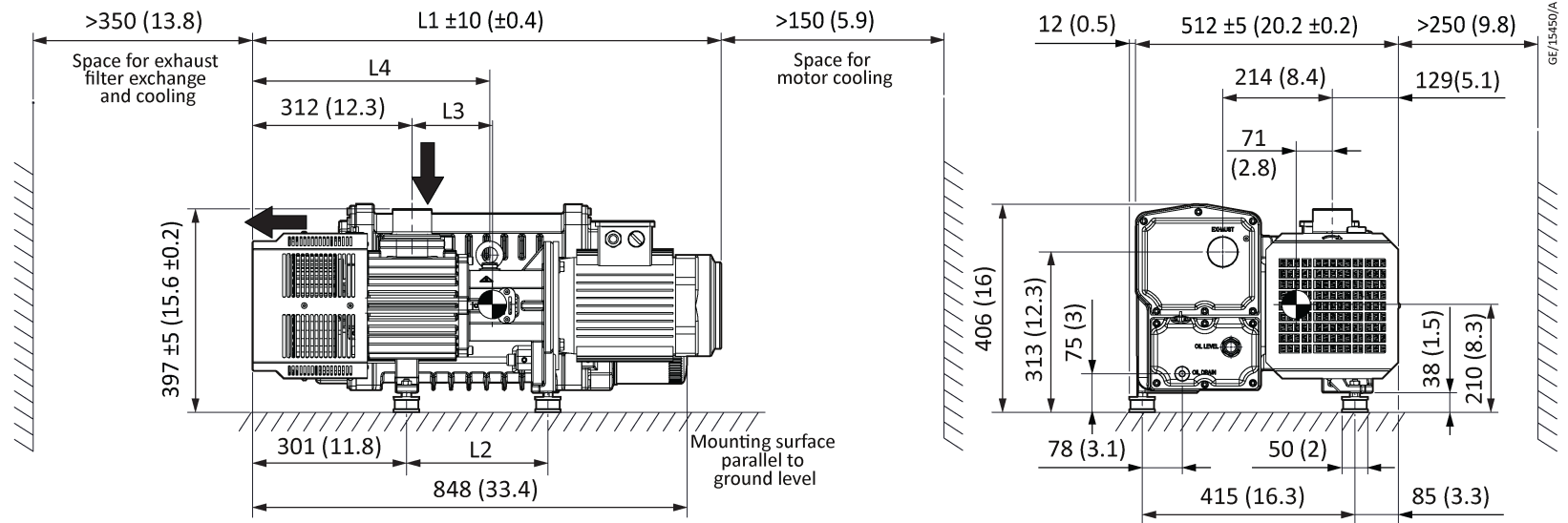
Motor variant	Designation	L1 #	L2	L3	L4	Pump Approx. mass in kg. #		
						Without oil	With oil	
Non Flame proof motor	3 Phase, 2.2 kW, 415V, 4 POLE, 50Hz, IE2	2031003000	691 [27.2]	253 [10]	323 [12.7]	138 [5.4]	80	82.3
	3 Phase, 2.2 kW, 415V, 4 POLE, 50Hz, IE3	2031003001					87	89.3
	3 Phase, 3.7 kW, 415V, 4 POLE, 50Hz, IE2	2031003002	732 [28.8]		340 [13.4]	170 [6.7]	104	106.3
	3 Phase, 3.7 kW, 415V, 4 POLE, 50Hz, IE3	2031003003					118	120.3
With Flame proof motor	3 Phase, 2.2 kW, 415V, 4 POLE, 50Hz, IE2	2031003004	759 [29.9]	370 [14.6]	170 [6.7]	104	106.3	
	3 Phase, 2.2 kW, 415V, 4 POLE, 50Hz, IE3	2031003005				118	120.3	
	3 Phase, 3.7 kW, 415V, 4 POLE, 50Hz, IE2	2031003006	769 [30.3]			390 [15.4]	170 [6.7]	104
3 Phase, 3.7 kW, 415V, 4 POLE, 50Hz, IE3	2031003007	118		120.3				

Figure 18 Dimension drawing bare shaft - GVS 100 R



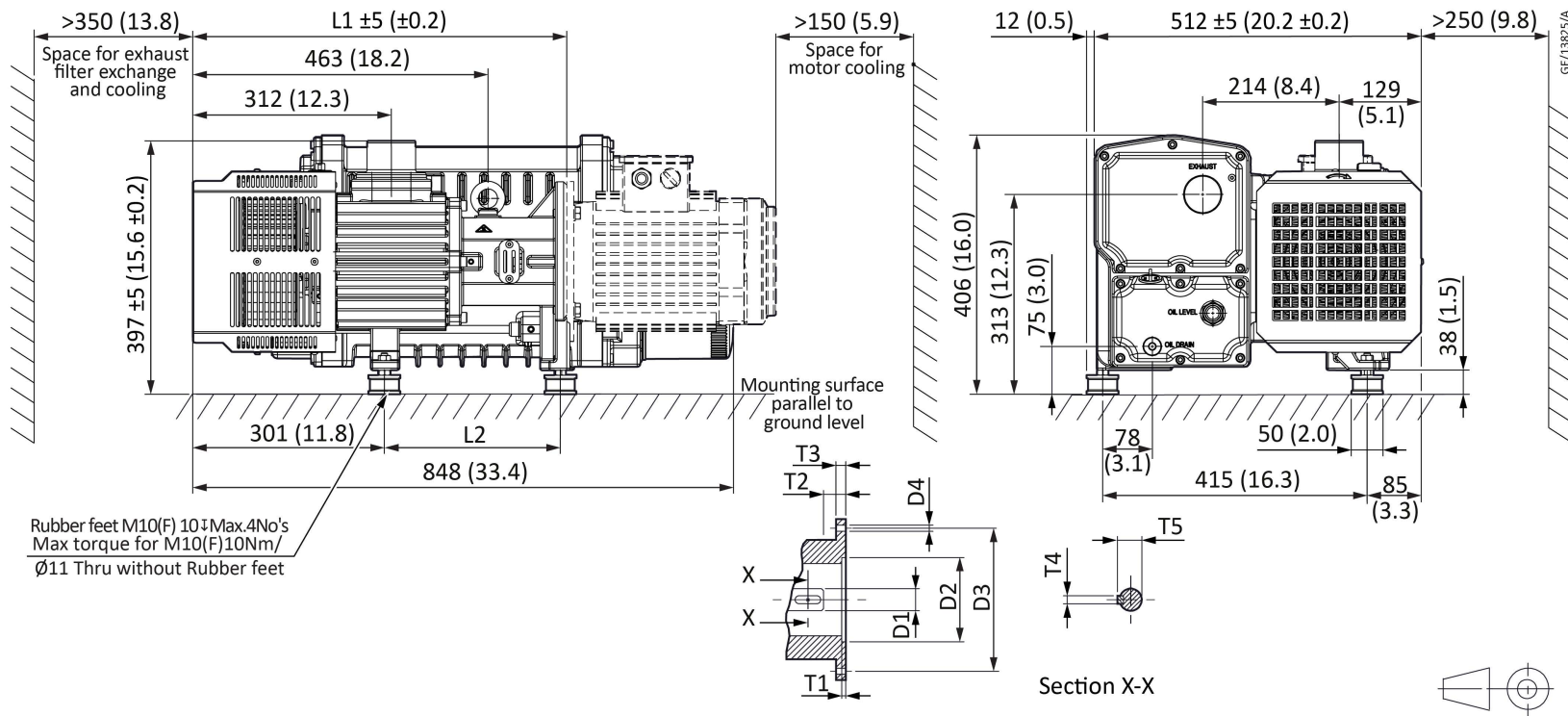
Pump Designation	Suitable for Motor	L1	L2	D1 h6	D2 +0.050 +0.025	D3	D4	T1	T2	T3	T4 h9	T5 +0.0 -0.2	Pump Approx. mass in kg.	
													Without oil	With oil
2031003008	2.2 kW, 4 Pole, B5, 100L frame	404 [15.9]	253 [10]	∅ 22	∅ 180	∅ 215	M12	5	78	15	8	25	55	57.3
	3.7 kW, 4 Pole, B5, 112M frame													

**Figure 19** Dimension drawing - GVS 200 R



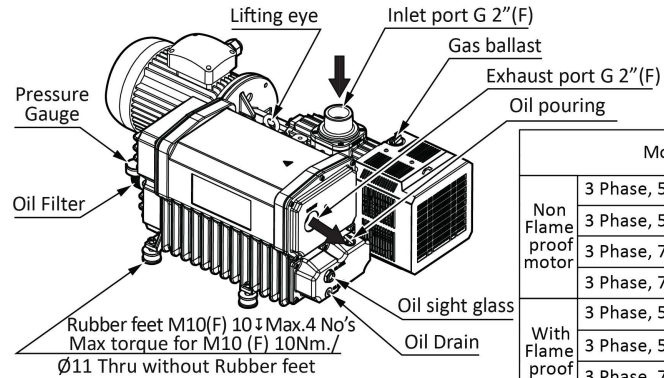
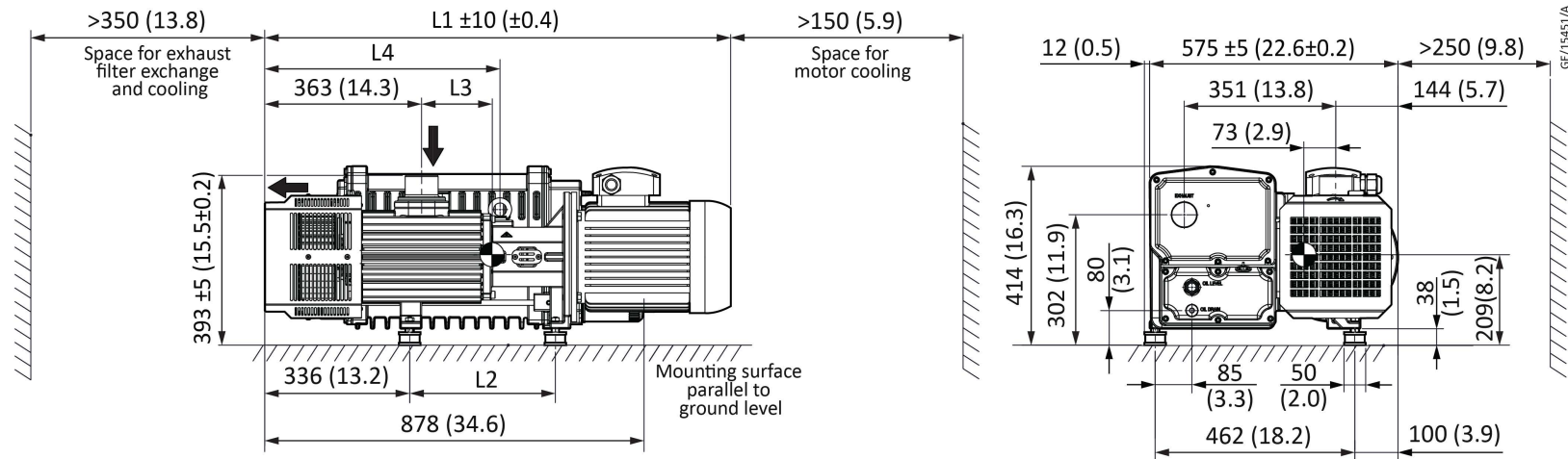
Motor variant	Designation	L1 #	L2	L3	L4	Pump Approx. mass in kg. #	
						Without oil	With oil
Non Flame proof motor	3 Phase, 3.7 kW, 415V, 4 POLE, 50Hz, IE2	2031004000	915 [36]	157 [6.2]	463 [18.2]	139	146
	3 Phase, 3.7 kW, 415V, 4 POLE, 50Hz, IE3	2031004001					
	3 Phase, 5.5 kW, 415V, 4 POLE, 50Hz, IE2	2031004002	976 [38.4]	178 [7]	442 [17.4]	159	166
	3 Phase, 5.5 kW, 415V, 4 POLE, 50Hz, IE3	2031004003					
With Flame proof motor	3 Phase, 3.7 kW, 415V, 4 POLE, 50Hz, IE2	2031004004	952 [37.5]	221 [8.7]	463 [18.2]	170	177
	3 Phase, 3.7 kW, 415V, 4 POLE, 50Hz, IE3	2031004005					
	3 Phase, 5.5 kW, 415V, 4 POLE, 50Hz, IE2	2031004006	1047 [41.2]	234 [9.2]	442 [17.4]	202	209
	3 Phase, 5.5 kW, 415V, 4 POLE, 50Hz, IE3	2031004007					

Figure 20 Dimension drawing bare shaft - GVS 200 R



Pump Designation	Suitable for Motor	L1	L2	D1 +0.000 -0.015	D2 +0.050 +0.025	D3	D4	T1	T2	T3	T4 h9	T5 +0.00 -0.15	Pump Approx. mass in kg.	
													Without oil	With oil
2031004008	3.7 kW, 4 Pole, B5, 112M frame	587[23.1]	276[10.9]	$\varnothing$ 28	$\varnothing$ 180	$\varnothing$ 215	M12	5	84	18	8	31	107	114
2031004009	5.5 kW, 4 Pole, B5, 132S frame	607[23.9]			$\varnothing$ 230	$\varnothing$ 265	M12	5	104	8	31	109	116	

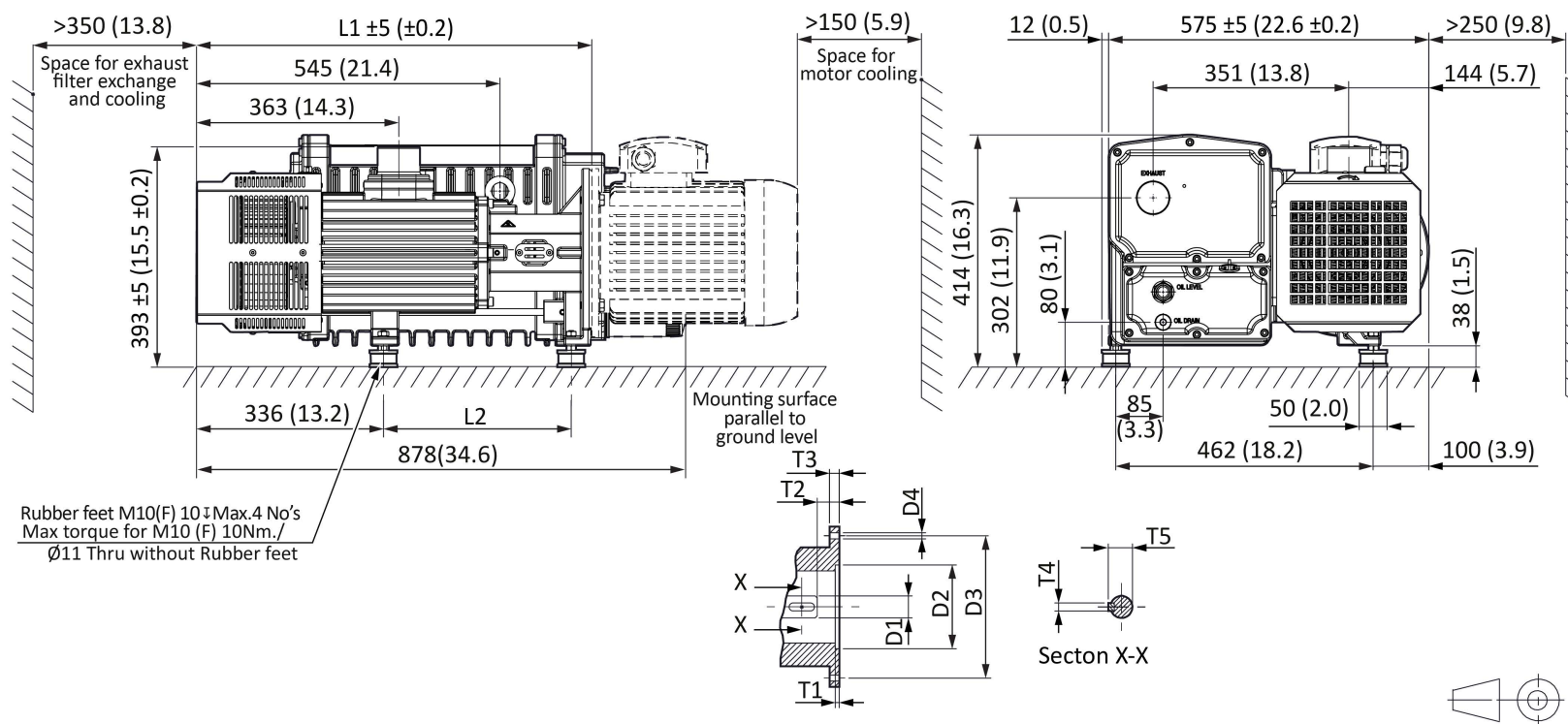
**Figure 21** Dimension drawing - GVS 300 R



	Motor variant	Designation	L1 #	L2	L3	L4	Pump Approx. mass in kg. #	
							Without oil	With oil
Non Flame proof motor	3 Phase, 5.5 kW, 415V, 4 POLE, 50Hz, IE2	2031005000	1079 [42.5]	337 [13.3]	163 [6.4]	545 [21.4]	193	202
	3 Phase, 5.5 kW, 415V, 4 POLE, 50Hz, IE3	2031005001						
	3 Phase, 7.5 kW, 415V, 4 POLE, 50Hz, IE2	2031005002	209 [8.2]		210		219	
	3 Phase, 7.5 kW, 415V, 4 POLE, 50Hz, IE3	2031005003	225 [8.9]		230		239	
With Flame proof motor	3 Phase, 5.5 kW, 415V, 4 POLE, 50Hz, IE2	2031005004	1150 [45.3]	241 [9.5]	235	244		
	3 Phase, 5.5 kW, 415V, 4 POLE, 50Hz, IE3	2031005005	1180 [46.5]					
	3 Phase, 7.5 kW, 415V, 4 POLE, 50Hz, IE2	2031005006						
	3 Phase, 7.5 kW, 415V, 4 POLE, 50Hz, IE3	2031005007						



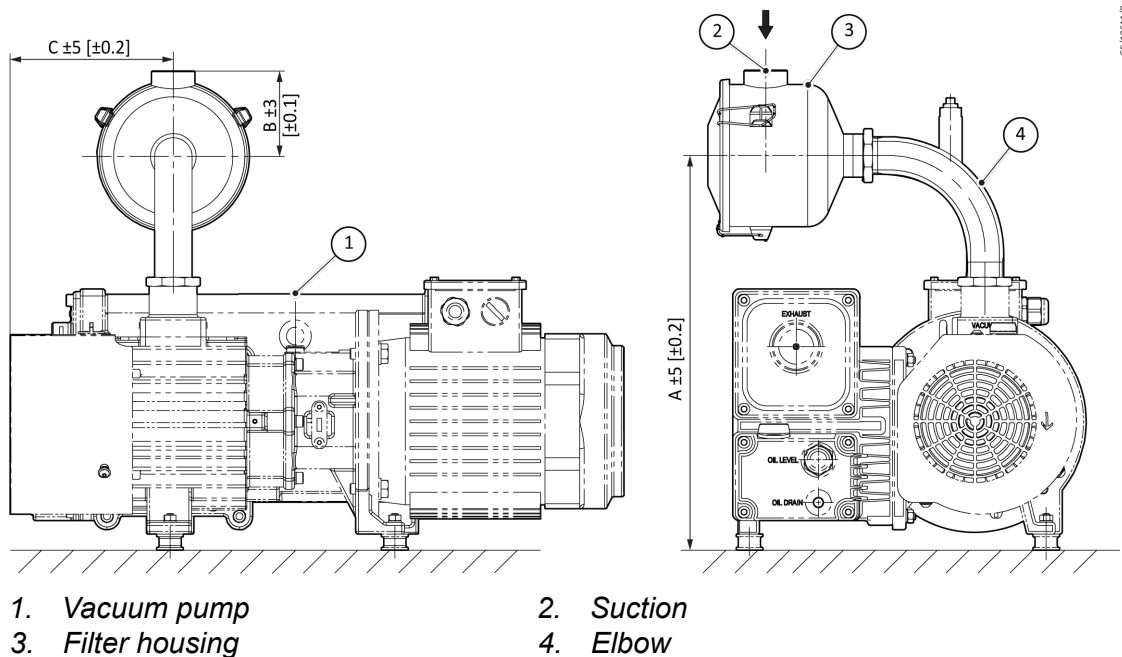
Figure 22 Dimension drawing bare shaft - GVS 300 R



Pump Designation	Suitable for Motor	L1	L2	D1 +0.000 -0.015	D2 +0.045 -0.025	D3	D4	T1	T2	T3	T4 h9	T5 +0.0 -0.2	Pump Approx. mass in kg.	
													Without oil	With oil
2031005008	5.5 kW, 4 Pole, B5, 132S frame	710[27.9]	337[13.3]	Ø28	Ø230	Ø265	M12	5	104	18	8	31	140	147
	7.5 kW, 4 Pole, B5, 132M frame													

### 4.3. Inlet dust filter (optional)

**Figure 23** Dimension drawing - Inlet dust filter (optional)



62/10611/P

**Table 1** Dimensions - Inlet dust filter (optional)

	GVS 16 R	GVS 40 R	GVS 65 R	GVS 100 R	GVS 200 R	GVS 300 R
A	352 (13.9)	407 (16.0)	407 (16.0)	450 (17.7)	565 (22.2)	565 (22.2)
B	68 (2.7)	96 (3.8)	96 (3.8)	96 (3.8)	137 (5.4)	137 (5.4)
C	59 (2.3)	135 (5.3)	158 (6.2)	180 (7.1)	312 (12.2)	363 (14.3)

**Table 2** Part numbers - Inlet dust filter assembly (optional)

	GVS 16 R	GVS 40 R/GVS 65R/ GVS 100 R	GVS 200 R/ GVS 300 R
Filtering element type			
• Polyester (Cloth media)	2031000576	2031003575	2031005575
• S.S.Mesh	2031000578	2031003577	2031005577
Approximate mass of filter assembly (Kg)	1.1	3.2	6.8

**Note:**

If the air intake filter is delivered loose, install it in a leak-tight position.

When the air intake filter element is replaced, the dust can fall into the pump inlet and damage the pump. The air intake filter must be installed in a horizontal position to prevent filtered dust falling into the pump inlet.

## 4.4. Performance data

**Table 3 Performance data - GVS 16 R, GVS 40 R, GVS 65 R and GVS 100 R**

Parameter	Units	GVS 16 R	GVS 40 R	GVS 65 R	GVS 100 R
		50 Hz	50 Hz	50 Hz	50 Hz
Nominal pumping speed	m <sup>3</sup> /h	17	43	65	102
Ultimate Pressure without gas ballast (Total pressure)	mbar	≤ 0.3	≤ 0.1		
Ultimate Pressure with standard gas ballast (Total pressure)	mbar	≤ 1.5			
Leak rate	mbar l/s	1 x 10 <sup>-3</sup>			
Noise level* (DIN 45 635)	dB (A)	63	60	64	65
Water vapour tolerance (IS:6849)	mbar	40			
Water vapour pumping capacity (IS:6849)	kg/h	0.4	0.9	1.4	2.2

\* Measured at ultimate vacuum, 1 meter from the end of pump to ISO 11201, 50 Hz operation.

**Table 4 Performance data - GVS 200 R and GVS 300 R**

Parameter	Units	GVS 200 R	GVS 300 R
		50 Hz	50 Hz
Nominal pumping speed	m <sup>3</sup> /h	192	300
Ultimate Pressure without gas ballast (Total pressure)	mbar	≤0.1	≤0.3
Ultimate Pressure with small gas ballast (Total pressure)	mbar	≤0.8	
Ultimate Pressure with standard gas ballast (Total pressure)	mbar	≤1.5	≤1.8
Ultimate Pressure with big gas ballast (Total pressure)	mbar	≤2	≤2.5
Water vapour tolerance small gas ballast (IS:6849)	mbar	20	
Water vapour pumping capacity small gas ballast (IS:6849)	kg/h	1.5	2.4
Water vapour tolerance standard gas ballast (IS:6849)	mbar	30	

Parameter	Units	GVS 200 R	GVS 300 R
		50 Hz	50 Hz
Water vapour pumping capacity standard gas ballast (IS:6849)	kg/h	2.5	4.5
Water vapour tolerance big gas ballast (IS:6849)	mbar	40	60
Water vapour pumping capacity big gas ballast (IS:6849)	kg/h	4	6
Leak rate	mbar l/s	$1 \times 10^{-3}$	
Noise level (DIN 45 635)	dB (A)	69	72

**Note:**

*In all tables total pressures have been measured by a capacitance manometer on a vacuum chamber without a cold trap, as specified by Pneurop Standard 6602 (1979).*

**Table 5 Operating and storage conditions**

Parameter	Value
Ambient operating temperature range	12 to 40 °C
Ambient temperature range (storage)	-30 to 70 °C
Normal surface temperature of the pump body*	50 to 70 °C
Maximum humidity (operation)	90% RH
Maximum altitude (operation)	2000 m

\* At ultimate vacuum, with ambient temperature of 20 °C.

## 4.5. Mechanical data

**Table 6 Mechanical data**

Pump	GVS 16 R	GVS 40 R	GVS 65 R	GVS 100 R	GVS 200 R	GVS 300 R
Dimensions	Refer to Dimension drawings					
Degree of protection (IEC 34-5: 1981) 3-phase motor	IP55					

Mass with motor (Kg) approximately (without oil)	29	55	59	80	139	193
Nominal motor rotational speed (rpm) 50 Hz Electrical supply	1500	1000	1500			

## 4.6. Lubrication data

The single stage vacuum pumps should be run with oil having viscosity according to ISO category VG68. For other oil usage contact pump supplier.

**Table 7 Lubrication data**

Pump	GVS 16 R	GVS 40 R	GVS 65 R	GVS 100 R	GVS 200 R	GVS 300 R
Oil capacity (liter)	1	1.8	1.8	2.5	8	9.5
Recommended oil*	Mineral oil - ISO VG68					

*\*To operate the pump when the ambient temperature is outside the limits specified in Section [Operating and storage conditions](#) on page 36 or to optimize the pump performance when you pump condensable vapours, you may need to use different oil.*

## 4.7. Oil specification

**Table 8 Oil specification**

Parameters	Value
Kinematic viscosity at 40 °C (cSt)	67
Kinematic viscosity at 80 °C (cSt)	15
Kinematic viscosity at 100 °C (cSt)	9.9
Flash point (°C)	240

*For equivalent oil contact pump supplier*

## 4.8. Electrical data



### CAUTION: HAZARDOUS VOLTAGE

The motors are specific for the supply voltage and frequency. Do not attempt to use the motor with either the incorrect voltage or frequency.

#### 4.8.1. Electrical data for pump with three-phase motor

The pump will start at a temperature down to 12 °C. At low temperatures the motor will draw the start-up current for several seconds. The current will then reduce quickly as the motor reaches rated rotational speed. Within few minutes, as the oil and pump warms up, the current drawn will slowly reduce to a maximum of the full load current.

Electrical short-circuit and ground-fault protection of the pump will be provided by fitting Class CC fuses, as per EU norms at the point of connection to the supply.

If these are not available in your country, use type aM European fuses of the same rating.

**Table 9 Electrical data for pump with three-phase motor**

Pump	Nominal supply (V)	Frequency (Hz)	Power (kW)	Full load current (A)*	Start-up current (A)	Maximum fuse rating (A)
GVS 16 R	373-456	50	0.55	1.6	9.6	4
GVS 40 R			1.1	2.75	11	6
GVS 65 R			1.5	3.5	17.5	10
GVS 100 R			2.2	5	28.5	15
GVS 200 R			3.7	7.5	45	15
GVS 300 R			5.5	11	66	25

\* For actual full load current refer specification on motor name plate.

 **Note:**

*We recommend that you use fuses of the maximum ratings specified. Do not use fuses of a higher rating.*

## 5. Installation

### 5.1. Installation Guidelines

- The following list must be used as a guide for the installation of GVS vacuum pumps. The list is not exhaustive. Every vacuum pump installation is unique and care must be exercised in the placement of each pump. If you are unsure of any installation variable, please consult us.
- Install the pump on a solid, level surface, suitable for taking its weight. Respect the minimal distance between the pump and the walls (Refer to [Dimension drawings](#) on page 22).
- Correct process lines sizes have to be used to prevent restrictions and resulting pressure drops. As a rule of thumb, the inlet diameter of the pump should be maintained as far into the process as possible. Consult us for piping recommendations.
- The required ventilation capacity to limit the vacuum pump room temperature can be calculated from  $Q_v = 0.2 N/\Delta t$ , with:
  - $Q_v$  = required ventilation capacity in  $m^3/s$
  - $N$  = shaft input of the vacuum pump in kW
  - $\Delta t$  = temperature increase of the incoming ventilation air in the vacuum pump room in  $^{\circ}C$
- Make sure all piping connections from the pump to the point of use are leak tight and secure. Leaks add load to the vacuum pump. They decrease the available pump capacity and spoil the attainable ultimate pressure. All welds must be vacuum compatible.
- Vacuum rated isolation valves must be used. Compressed air valves and vacuum valves differ in their sealing characteristics and compressed air valves may leak in vacuum applications.
- All piping should be as straight as possible with non-restrictive diameters. Elbows, bends, tees and tapers should be used only when absolutely necessary.
- Keep plumbing and system free of fluids, water, dirt, and debris that are not part of the process. These can cause obstructions in the vacuum flow through the piping and can reduce available pumping capacity.
- Use a suitable valve to isolate the pump from your vacuum system if you need to allow the pump to warm up before you pump condensable vapours or to provide additional system protection when the pump is switched off.
- Unintentional air leak to vacuum chamber through vacuum pump as well as oil suck-back to vacuum chamber when pump is shut down is avoided by the integrated anti suck-back valve. In applications where an oil suck-back must be avoided by all means, it is recommended to install a dedicated valve in the pump inlet line.
- Exhaust piping should be installed in such a manner that it does not create additional back pressure on the vacuum pump. Also, the exhaust piping should be installed sloping away from the vacuum pump.
- A recommended alternative is the use of a drip leg with drain point provision, to prevent condensate from running back into the fluid reservoir.

- Take extreme care in selecting the proper inlet filtration system for the vacuum pump. Liquids, solids and abrasive powders must be prevented from entering the vacuum pump to prevent mechanical failure or reduced lifetime. Inlet filtration must be installed on every pump. The potential for particulate contamination in rough vacuum applications is significant. The particle micron retention of the filter element must be smaller than the smallest possible particle load. Also, the inlet filter should be mounted in such a way to prevent particles from falling into the inlet of the vacuum pump during cleaning or changing of the filter element.
- If there is a risk for liquids to be drawn into the vacuum system, a liquid separator should be used to separate these liquids from the incoming air. In applications where there is significant amount of liquid, consult us.
- Keep the vacuum pump room dry and free from contamination.
- Follow recommended lubricant change schedules in normal applications (air) and watch closely the condition and appearance of the fluid in chemical or harsh applications. Check the leak rate of the system by pumping down to the ultimate pressure and then valve off the vacuum pump. Monitor the pressure rise over a period of five or ten minutes and record this rate of rise for future reference. This value is a good tool to have if you believe there are pump or system problems. Compare new value with the original.
- When pumping condensable vapours and particulates, more frequent fluid changes are required to maintain pump life. Consult us for types and styles of filtration units.
- Be sure there is no back pressure on the exhaust line of the vacuum pump. Vacuum pumps are not specifically designed to compress exhaust gas above atmospheric pressure. Significant back pressure can overheat the pump and cause motor overloading. Back pressure on the pump should not exceed 0.15 bar(e) under normal operating conditions.
- Maintain system seals on a regular basis. Damaged O-rings and gaskets must be replaced immediately. All flange faces must be free of dirt, lubricant and scratches.
- Do not use collapsible tubing to plumb the vacuum system. Any restrictions in line diameter caused by tube collapse will reduce available pumping capacity.
- In multiple pump installations, check valves should be installed in the inlet piping. This will prevent fluid from being drawn from an 'off' unit into an operating unit. Check valves should be properly sized so as not to "chatter" during operation. Spring loaded, elastomer seated check valves are recommended. These should be mounted in a horizontal flow orientation.
- Using properly sized actuated valves is even a better solution. This generally results in a lower pressure drop when open and in a better sealing when closed.
- Vacuum gauge ports and gauges should be installed in each leg of central vacuum piping. This provides a diagnostic tool for troubleshooting both the application and any pump related problems.
- Make sure that no temperature sensitive parts (plastic, wood, cardboard, paper, electronics) will touch the surface of the vacuum pumps.
- Ambient and inlet temperature may never exceed the limits of the pump's working range. Make sure the installation location is vented such that a sufficient cooling of the vacuum pumps is available.



## 5.2. Unpacking and inspection of pump

- Remove all packing materials. If found that the pump is damaged, notify your supplier and the carrier in writing immediately; state the serial number of the pump together with your order number and your supplier's invoice number. Retain all the packing materials for inspection. Do not use the pump if it is damaged.
- Remove the protective covers from the inlet and outlet-ports Inspect the pump.

If the pump is not to be used immediately, use protective covers. Store the pump in suitable conditions, as described in section [Storage](#) on page 60.

## 5.3. Pump handling and location



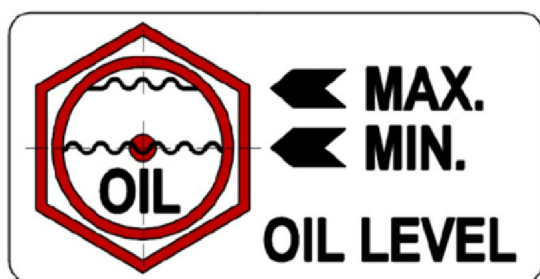
### WARNING: HEAVY OBJECT

Risk of physical injury. Suitable lifting equipment should be used.

- The pumps have a lifting eye on top of pump, used for lifting. Alternatively you may use slings around the motor and the pump body to lift the pump.
- Provide a firm, level platform for the pump. Locate the pump so that the oil level sight glass is visible and the oil pouring plug, oil drain plug and gas-ballast valve are accessible.
- If your pump will be located inside an enclosure, make sure that there is adequate ventilation at both ends of the pump, so that the ambient temperature around the pump does not exceed 50 °C. There must be sufficient space between the pump and the enclosure walls.

## 5.4. Oil Filling

Figure 24 Oil level



Follow the steps to fill oil in the pump

1. Remove the oil pouring-plug.
2. Pour the oil into the pump until the oil-level just reaches the MAX (Maximum) level on oil level sight glass. If the oil level goes above the MAX level excess oil can be drained using the oil drain plug.
3. Refit the oil pouring-plug; tighten the plug firmly by hand, do not over tighten.

4. Check the oil level after a few hours. If the oil-level is below the MIN (Minimum) level, add more oil to the pump.

## 5.5. Motor installation

Follow the process below to install motor to the pump:

1. Position the parallel key into the key way slot of pump shaft and insert the pump side coupling onto the pump shaft and tighten the grub screw using allen key.
2. Towards motor side coupling assembly, insert the parallel key into the key way slot of motor shaft and insert the motor side coupling onto the motor shaft and tighten the grub screw using 2.5 mm allen key for GVS 16/40 R, 3 mm allen key for GVS 65/100 R and 4 mm allen key for GVS 200/300 R.
3. Position the spider in coupling on the pump shaft and assemble the electric motor on flange of pump ensuring the spigot on the motor is entering into the register of pump and fasten the motor using 4 Screw /Bolt with the spring washers in between on the respective threads.
4. Follow the coupling gap as mentioned in the below notes.

### Note:

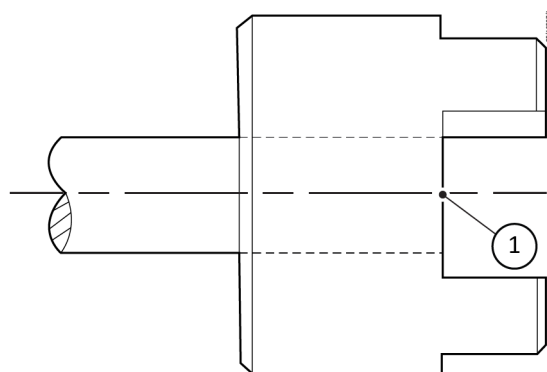
*The gap between the coupling faces after motor assembled to pump should be a minimum 2 - 3 mm (View gap by removing cover plate by unscrewing 2 screws ).*

*If necessary, adjust the position of the coupling hub on the motor shaft to maintain the gap.*

*The motor you will fit must have a power rating which is adequate for use with the pump: refer to the pump [Electrical data](#) on page 37 in the manual.*

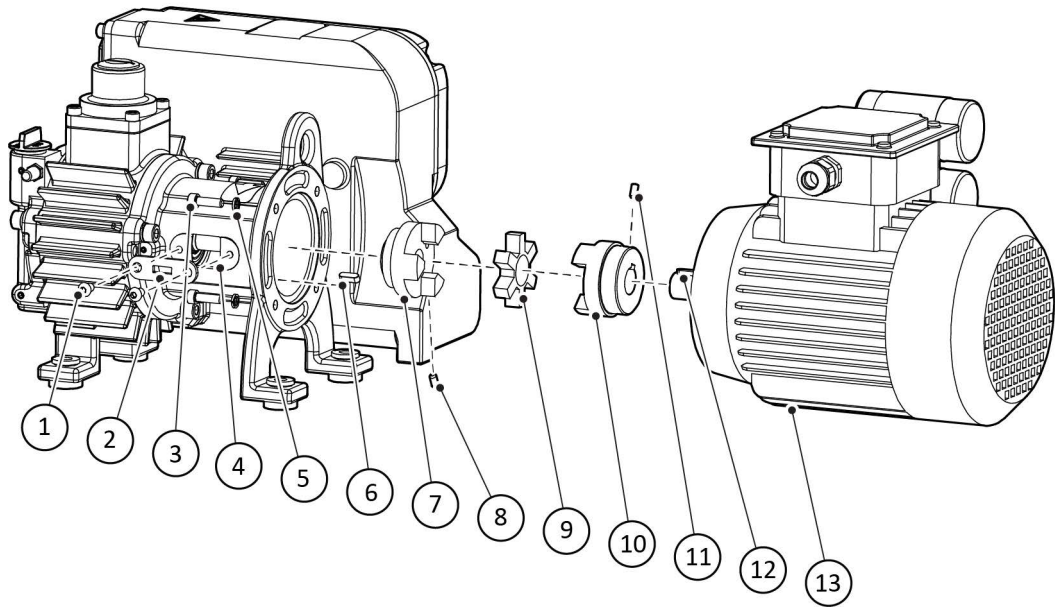
*The performance data given in section [Performance data](#) on page 35 applies to pump supplied with a motor fitted as standard. On a bare shaft pump, the performance may be affected by the type of motor fitted.*

**Figure 25** Pump and Motor coupling alignment



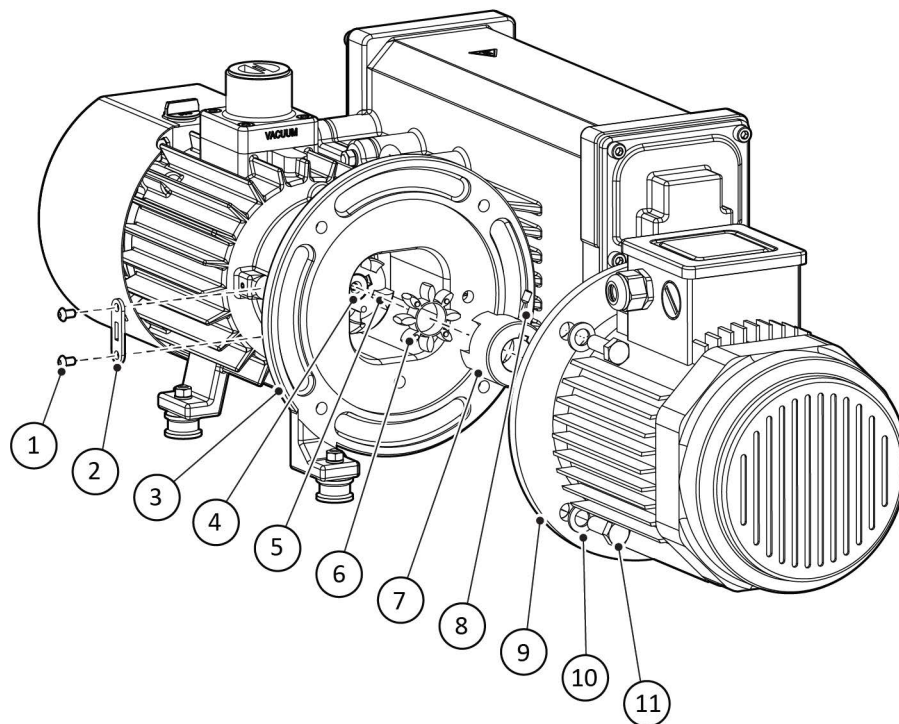
1. *Pump and motor half  
Couplings should flush with the  
corresponding shafts*

**Figure 26** GVS 16 R and GVS 40 R Motor installation



GE/10586/A

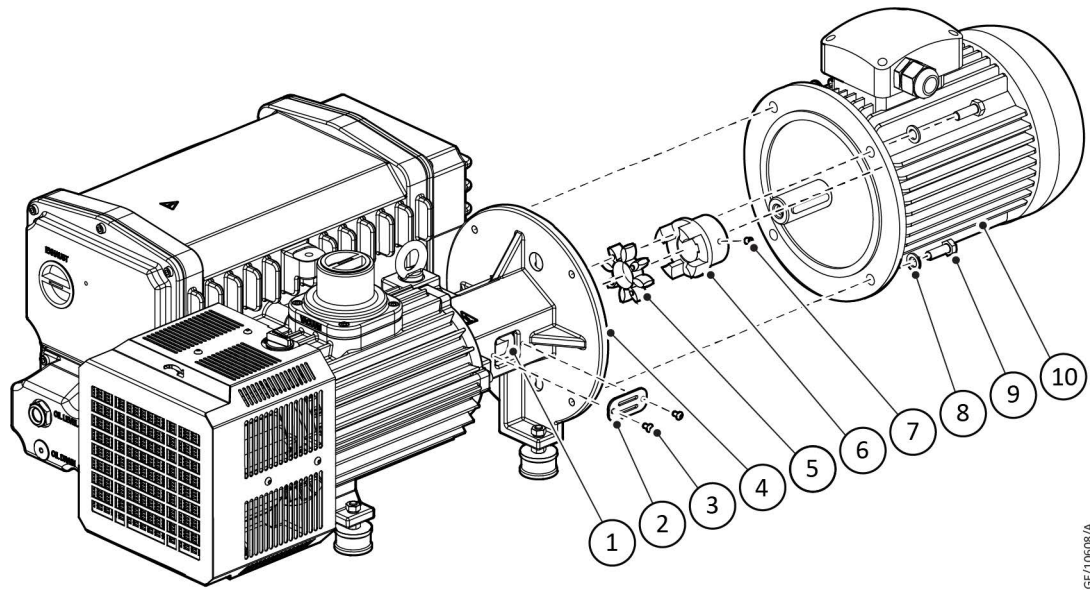
- |                       |                         |
|-----------------------|-------------------------|
| 1. Screw (x2)         | 2. Cover plate          |
| 3. Bolt/Screw (x4)    | 4. Pump shaft           |
| 5. Spring washer (x4) | 6. Parallel key         |
| 7. Pump side coupling | 8. Grub screw           |
| 9. Spider             | 10. Motor side coupling |
| 11. Grub screw        | 12. Parallel key        |
| 13. Electric motor    |                         |

**Figure 27** GVS 65 R and GVS 100 R Motor installation

GE/10600/A

- |                        |                        |
|------------------------|------------------------|
| 1. Screw (x2)          | 2. Cover plate         |
| 3. Flange of pump      | 4. Pump shaft          |
| 5. Coupling            | 6. Spider              |
| 7. Motor side coupling | 8. Grub screw          |
| 9. Electric motor      | 10. Spring washer (x4) |
| 11. Bolt/Screw (x4)    |                        |

Figure 28 GVS 200 R and GVS 300 R Motor installation



- |                    |                        |
|--------------------|------------------------|
| 1. Coupling        | 2. Cover plate         |
| 3. Screw (x2)      | 4. Flange              |
| 5. Spider          | 6. Motor side coupling |
| 7. Grub screw      | 8. Spring washer (x4)  |
| 9. Bolt/Screw (x4) | 10. Electric motor     |

GE/10608/A

## 5.6. Electrical connections

Always use a protection system, including an overcurrent protection and an electrical disconnecting device, between the pump and the electric power supply.

Motor currents can be found on the motor data plate. The pump is normally delivered without electrical cable and without switch. For the electrical connection, check the diagram inside the terminal box or on the motor data plate.

### 5.6.1. Motor configuration



#### CAUTION: DAMAGE TO EQUIPMENT

Risk of motor damage. Make sure you are using a motor suitable for your power supply. Failure to use the correct motor will permanently damage the motor.

Follow the steps below to configure the motor:

1. Remove the screws which secure the cover of the motor terminal-box, remove the cover.
2. Remove the cable-gland from the inside of the terminal-box and fit the cable-gland to the cable lead through hole in the side of the terminal-box.
3. Make sure that the motor is correctly configured for your electrical supply. If necessary, reconfigure the links to suit your electrical supply.
4. For 415 V electrical supplies, the links must be configured as shown in [Figure: Electrical connections three phase motor](#).

## 5.6.2. Power supply wiring for pump with three-phase motor



### **WARNING: ELECTRICAL HAZARD**

The electrical installation must conform to your local and national safety requirements. The pump must be connected to a suitable electrical supply which is fused and protected. A suitable earth (ground) point must be provided.

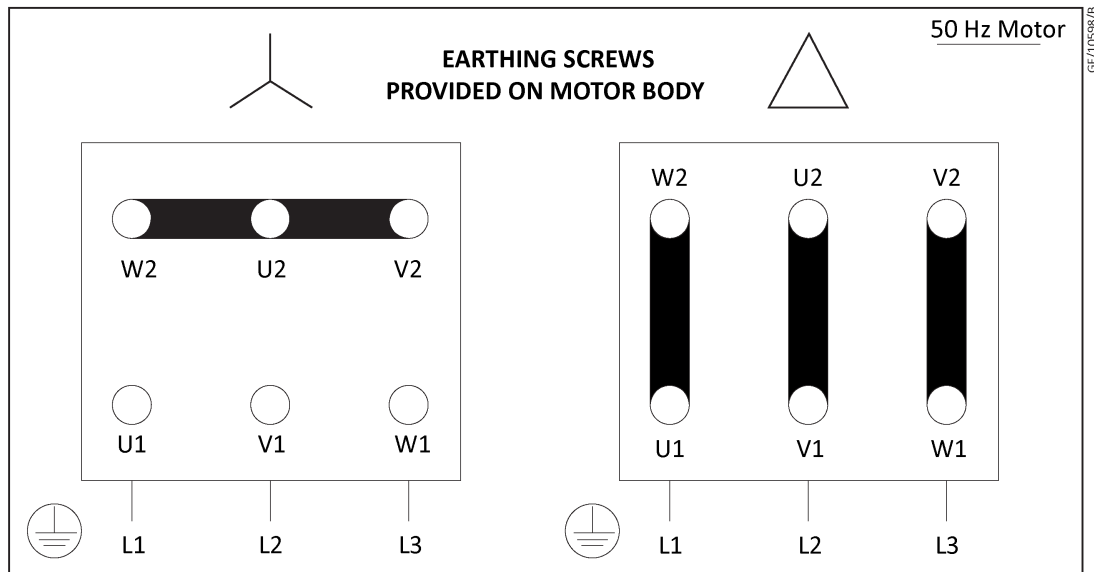
#### **Note:**

*To prevent automatic restart of the pump motor after an electrical supply failure, connect the pump to the electrical supply through correct control equipment which must be reset manually after an electrical supply failure.*

We recommend that you connect the electrical supply to the motor through a starter or circuit breaker which has thermal over current protection which can be adjusted to suit the full load current ratings shown in [Table: Electrical data for pump with three-phase motor](#). The fuse ratings are provided for guidance only. The supplier of your thermal over-current protection device may specify different values to make sure correct operation of the fuse and the over-current protection device. Make sure that the fuse you use is correct for the starting currents.

Follow the steps below to connect electrical supply cables to the motor:

1. Pass the electrical supply cable through the cable-gland. For electrical supply cable detail, refer to the motor data sheet.
2. Use insulated crimped connectors to connect the wires in the cable to the terminals in the terminal box. Tighten the earth (ground) terminal connection.
3. Make sure that the cover gasket is correctly positioned, then refit the cover to the terminal-box and secure with the screws. Tighten the strain-relief nut onto the cable-gland.

**Figure 29** Electrical connections three phase motor**Note:**

For the electrical connection, check the diagram inside the terminal box or on the motor data plate.

**5.6.3. Check the direction of pump rotation with three-phase motor****CAUTION: EQUIPMENT DAMAGE**

Risk of equipment damage. Make sure that the motor rotates in the correct direction. If it does not, the pump and the vacuum system can become pressurised when operating the pump.

Follow the steps below to check the direction of rotation of the pump:

1. View the cooling-fan through the grill of fan-cover on pump or motor.
2. Switch-on the electrical supply to the motor for a few seconds.
3. Check the radiator cooling-fan is rotating in correct direction as shown by the arrow on the radiator-cover. If the direction of rotation is incorrect:
  - Switch off the electrical supply immediately.
  - Isolate the pump from the electrical supply.
  - Remove the terminal-box cover and swap any two of the supply wires and check for direction of rotation. If problem persist contact the pump supplier.
  - Refit the cover to the terminal-box.

**5.7. Inlet connections**

- The pump inlet port has female threads which can be connected using a nozzle with a vacuum tight flexible hose or pipe and also an adapter can be used to convert the inlet according to your requirement. Refer to [Table: Inlet connections](#).

- The nominal diameter of the pipe has to be a minimum the same as the diameter of the pump's inlet flange. There must be no restriction in pipes to achieve the right pumping speed.
- If necessary, incorporate flexible bellows in your system pipelines to reduce the transmission of vibration and to prevent loading of coupling-joints. If you use flexible bellows, you must make sure that you use bellows which have a maximum pressure rating which is greater than the highest pressure that can be generated in your system. We recommend that you use pump suppliers flexible bellows.
- For optimum pumping speeds, make sure that the pipeline connected to the pumps inlet is as short as possible.
- The inlet pressure must not exceed atmospheric pressure.
- Use a suitable inlet trap if you pump condensable vapours or if you use the pump for very dusty applications.
- Use proper valve to isolate the pump from your vacuum system if you need to pump condensable vapours or maintain vacuum when the pump is switched Off.
- Make sure that sealing surfaces are clean and scratch-free for all inlet plumbing line joints.

**Table 10 Inlet connections**

Pump	Inlet connection
GVS 16 R	G 3/4" (F)
GVS 40 R, GVS 65 R and GVS 100 R	G 1 1/4" (F)
GVS 200 R and GVS 300 R	G 2" (F)

## 5.8. Exhaust connections



### **WARNING: DANGEROUS GASES**

Connect the exhaust to a suitable treatment plant to prevent the discharge of dangerous gases and vapours to the surrounding atmosphere. Use a catch pot to prevent the drainage of contaminated condensate back into the pump

- The exhaust port has female threads which can be used to connect exhaust line. In GVS 40 R, GVS 65 R and GVS 100 R the exhaust port is provided with a dust prevention valve. In GVS 200 R and GVS 300 R the exhaust port is provided with a exhaust diverter; remove the dust prevention valve or exhaust diverter if pipeline needs to be connected to the exhaust port. Refer to [Table: Exhaust connections](#).
- The nominal diameter of the pipe has to be a minimum the same as the diameter of the pumps exhaust connection.
- It must be installed in such a manner so that no condensate can enter the pump. No isolation or restricting should be installed in the exhaust line of the pump.
- Excessive pressure in the pump could damage the seals, blow out the sight glass, or rupture the pump housing. In addition to this explosion hazard,



excessive backpressure can result in hazardous process gases leaking out of the pump.

- To monitor the back pressure in oil reservoir, you can connect a pressure gauge in oil reservoir. Refer the [Table: Exhaust back pressure gauge connections](#). The maximum exhaust pressure in oil reservoir must not exceed 0.5 bar gauge, (1.5 bar absolute), nor fall under atmospheric pressure by 15 mbar. If you are purging the oil casing with inert gas, limit the inert gas flow. Contact pump supplier for recommendations.

**Table 11 Exhaust connections**

Pump	Exhaust connection
GVS 16 R	G 3/4" (F)
GVS 40 R, GVS 65 R and GVS 100 R	G 1 1/4" (F)
GVS 200 R and GVS 300 R	G 2" (F)

**Table 12 Exhaust back pressure gauge connections**

Pump	Exhaust back pressure gauge provision	Position
GVS 16 R	G 1/4" (F)	Dummy plug at the top of oil reservoir
GVS 40 R, GVS 65 R and GVS 100 R	M24x1.5 (F)	Connect gauge in oil pouring port with adapter
GVS 200 R and GVS 300 R	G 1/4" (F)	Pressure monitoring gauge fitted as standard

## 5.9. Leak check

Leak-test the system and arrest any leaks found after you have installed the pump, to prevent leakage of substances out of the system and leakage of air into the system.

## 6. Operation



### CAUTION: PIPE BLOCK

Risk of pump damage. Make sure that your system design does not allow the exhaust pipeline to be blocked.

Persons switching on remotely controlled machines shall take adequate precautions to ensure that there is no one checking or working on the machine. To this end, a suitable notice shall be affixed to the remote start equipment.

People staying in environments or rooms where the sound pressure level reaches or exceeds 80 dB(A) shall wear ear protectors.

Never remove or tamper with the safety devices, guards or insulations fitted on the machine.

The oil separator tank can be slightly pressurized. Do not open and do not leave oil filler or drain plugs open during operation.

Do not use the pump as a compressor.

Never run the pump without the air intake filter mounted.

### 6.1. Initial start-up preparation

- Check the process lines for the correct size to prevent high pressure drop and for cleanliness to protect the vacuum pump.
- Make sure the pump outlet is not obstructed.
- Check that the electrical connections correspond to the applicable codes and that all wires are clamped tight to their terminals. The installation must be earthed and protected against short circuits by fuses of the inert type in all phases. An isolating switch must be installed near the vacuum pump.
- Switch on the voltage and switch it off immediately. Check the direction of drive motor rotation while the motor is about to stop. The correct direction of rotation of the drive motor is indicated by an arrow shown on the motor fan cowl. If the direction of the drive motor is incorrect, open the isolating switch and reverse two incoming electric lines. Incorrect rotation of the drive motor may cause damage to the vacuum pump.
- Start and run the vacuum pump for a few minutes. Check that the vacuum pump operates normally.

 **Note:**

*If you intend to apply the vacuum pump on humid applications, it is recommended that the unit can achieve optimal running temperature before it is effectively put in operation. This can be done by running the unit against a closed suction line for 30 minutes with open gas ballast.*

*Gas ballast location and use is indicated on the pump data plate.*

*The pump is supplied filled with oil.*

## 6.2. Start-up procedure

### CAUTION: EXCESSIVE ENERGY CONSUMPTION



Risk of damage to equipment. To avoid excessive energy consumption and damage to the vacuum pump the maximum allowed starting frequency is 6 starts per hour.

For more frequent operation, let the pump operate continuously and control the vacuum demand by a pitot valve on the pump inlet.



### CAUTION: OVERPRESSURE

Risk of pump damage. High pressure is generated, if exhaust not opened.

To avoid overloading the motor, do not start the pump more than 6 times within one hour. If necessary to start more than 6 times per hour, keep the pump running and mount a valve with opening and closing into the inlet line.

If the oil is contaminated or if the pump temperature is below 12 °C or if the electrical supply voltage is lower than 10% below the lowest voltage specified on the voltage indicator, the pump may operate at a reduced speed for a few minutes.

To start the pump:

1. Check that the pump oil-level is between the MAX and MIN level on oil-level sight-glass, if it is not, refer to section [Oil-level check](#) on page 54.
2. Switch on the electrical supply to the pump.

## 6.3. Pumping of condensable vapours

1. Close the vacuum system isolation-valve.
2. Open gas ballast valve and operate the pump for 1 hour. This will help to prevent vapour condensation in the pump by heating the pump and the oil.
3. Open the vacuum system isolation-valve.
4. After you have pumped condensable vapours, you can (if necessary) decontaminate the oil: use the procedure in section [Oil decontamination](#) on page 51.

## 6.4. Oil decontamination

The oil in the pump should be clear, if the oil is cloudy or discoloured and contaminated with process vapours, change the oil.

If the pump has been pumping condensable vapours such as water, the following procedure can be used to stop the oil permanently contaminated.

1. Look at the condition of the oil in the oil level sight glass. If the oil is cloudy or discoloured, continue with the procedure at Step 2 below.
2. Close the vacuum system isolation-valve.

3. Open the gas ballast valve.
4. Operate the pump until the oil is clear

## 6.5. During operation

Regularly check the oil level and the oil condition. The oil level should be in the middle of the oil sight glass. Refer to [Oil-level check](#) on page 54.

### Note:

*The operator must apply all relevant safety precautions. Refer to [Safety precautions during operation](#) on page 10 and [Fault finding](#) on page 62.*

## 6.6. Stop the pump

We recommend running the unit off-line for typically 30 minutes with closed inlet valve but open gas ballast prior to switching off. This will condition the oil ready for the next start.up. If the gas stream was heavily contaminated with water vapour, a longer period of running the unit off-line will extend the oil lifetime.

If the pump is stopped before all the condensed vapour has been disposed off, it will be deposited by gravity separation from the oil on the bottom of the oil after about 8 to 10 hours.

We recommend, as described in the procedure below, that you decontaminate the oil before you shut down the pump; this will prevent damage to the pump by the contaminates in the oil.

1. Refer to [Oil decontamination](#) on page 51 and decontaminate the oil, as required.
2. Close the vacuum system isolation-valve (if not already closed).
3. Close gas ballast valve.
4. Switch off the electrical supply of the pump.

In case of long machine downtime, refer to [Taking out of operation](#) on page 52.

## 6.7. Taking out of operation

1. Switch off the voltage and disconnect the vacuum pump from the mains.
2. Drain the oil.
3. Recycle the oil, oil filter and exhaust filters as per the local environmental regulations for waste disposal and recycling.

## 7. Maintenance

### 7.1. Maintenance plan

Before carrying out any maintenance, repair work or adjustments, proceed as follow:

- Stop the vacuum pump.
- Switch off the voltage.
- Effectively isolate the machine from all sources of under and/or overpressure and make sure that the pump system is at atmospheric pressure level

The routine maintenance operations necessary to maintain the pump in normal use and the instructions for each operation are given in the section shown. Refer to [Table: Maintenance plan](#).

#### Warranty - Product Liability

Use only authorized parts. Any damage or malfunction caused by the use of unauthorized parts is not covered by Warranty or Product Liability.

#### Service contracts

We offer several types of service contracts, relieving you of all preventive maintenance work. Consult your nearest Customer Centre.

#### General

When servicing, replace all removed O-rings and washers.

#### Interval

The local Customer Centre may overrule the maintenance schedule, especially the service intervals, depending on the environmental and working conditions of the vacuum pump.

The longer interval checks must also include the shorter interval checks.

**Table 13 Maintenance plan**

Operation	Duty		
	Normal	Medium	Harsh
Check oil level and condition	24 h	24 h	24 h
Clean dirt trap at pump inlet	Monthly	Monthly	Monthly
Clean anti suck back valve at pump inlet	Yearly	Yearly	Yearly
Change oil*, oil filter (if installed) and exhaust filter			
▪ Mineral oil	4000 h	2000 h	1000 h

Operation	Duty		
	Normal	Medium	Harsh
Clean the pump, the radiator and the motor fan guard	2000 h	1000 h	500 h
Check the vanes. Replace them, if needed	15000 h	10000 h	5000 h

\* 1 year or whatever comes first.

**Note:**

We recommend monitoring the oil condition through the sight glass and to change the oil when it becomes discolored or milky. Not changing oil in time can lead to premature blocking of the air exhaust filter and even failure of the vacuum pump.

Also check for condensed water vapour on the bottom of the oil tank through the oil viewer (high water handling capability versions only). If there is condensed water vapour, open the oil discharge valve slightly, let the condensed water vapour flow out and close it again as soon as oil starts to come out. Check the oil level and top up if necessary.

## 7.2. Oil-level check

Figure 30 Oil level



**Note:**

If required, you can check the oil-level while the pump is operating, however you must switch off the pump and isolate the pump and other components in the pumping system from the electrical supply before you pour oil into the pump.

- Check the oil-level in the oil sight-glass is between the MAX and MIN level.
- If the oil level is near to or below the MIN level, pour more oil into the reservoir.
- If the oil level goes above the MAX level, drain the excess oil from the pump.
- If the oil is contaminated, drain and refill the pump with clean oil. Follow the instructions for replacing the oil into the pump, refer to [Replacement of Oil](#) on page 55.

## 7.3. Checking the oil condition



### CAUTION: LUBRICATION

Risk of pump damage. Residual condensates dilute the oil, deteriorate its lubrication properties and can cause a seizure of rotor.

#### Note:

*The oil should be light, either transparent, a little foamy or a little tarnished. A milky discoloration that does not vanishes after sedation of the oil indicates contamination with foreign material. Oil that is either contaminate with foreign material or burnt must be changed*

*In case the oil appears to be contaminated with water or condensates despite proper use of gas ballast, clean the gas ballast filter with appropriate cleaning agent*

## 7.4. Replacement of Oil

1. Operate the pump to reach working temperature to warm the oil and then switch OFF the pump (this lowers the viscosity of the oil and enables it to be drained from the pump more easily).
2. During operation pumps will be hot and some pump-body surfaces could reach a temperature higher than 80 °C and can cause burn by touching. Take note of warning labels on the pump and use appropriate safety measures.
3. Isolate the pump from your electrical supply.
4. Remove oil pouring-plug.
5. Remove the drain-plug and allow the oil to drain into the container.
6. When the flow of oil slows down, screw back the oil drain plug, briefly switch ON the pump for maximum 5 seconds and switch it OFF. Remove the oil drain plug again and drain the remaining oil.
7. If the oil drained from the pump is contaminated, pour clean oil into the pouring-hole and allow it to drain out of the pump. Repeat this step until the oil reservoir in the pump has been thoroughly cleaned.
8. Refit the drain-plug with O-ring in place.
9. Fill a suitable container with clean oil and pour the oil into the pouring hole until the oil-level reaches maximum mark.
10. While disposing the used oil, please follow the regional environmental regulations.

## 7.5. Replacement of oil filter

1. The oil filter is located at the rear side of the oil tank towards motor side of pump. Oil filter is not available in GVS 16R.
2. Make sure the oil is drained from oil reservoir as describe in section [Replacement of Oil](#) on page 55 before replacing the oil filter.

3. Unscrew the oil filter and replace it with the new oil filter by moistening its sealing surface with oil and screw it manually.
4. Plug the oil drain plug and unscrew the oil pouring plug and fill the pump with fresh oil up to the bottom edge of the oil level sight-glass, run pump for a short time and then change the oil again. Use suitable oil as describe in section [Lubrication data](#) on page 37.
5. Depending on the process involved dangerous substances may escape from the pump and oil. Take appropriate action
6. While disposing the filter, please follow the regional environmental regulations.

## 7.6. Exhaust filter replacement

- Whenever you found there is oil mist coming out from exhaust and the pump is consuming more oil or back pressure gauge is indicating more than 0.5 bar (a) in oil reservoir, it signs that the exhaust mist filter is clogged. pump exhaust mist filters are designed with inbuilt bypass valve considering safety, when the exhaust filter element are clogged the bypass valve opens and the filter is bypassed to avoid any accident or damage to pump.
- The exhaust filters must be replaced more frequently if subjected to increased oil cracking products at high operating temperatures or aggressive media.
- To replace the exhaust mist filter remove exhaust flange with O-ring by opening screws on it and then remove the clamps over the exhaust mist filters and you can replace it with new exhaust mist filter with O-ring on it then reassemble.
- While disposing the filter, please follow the regional environmental regulations.

 **Note:**

*Inbuilt bypass valve is not available in GVS 16 R*

*During operation the exhaust mist filter get saturated with oil. It is therefore normal that that the oil level will be drop slightly after replacement of exhaust mist filters.*

## 7.7. Cleaning instruction

### 7.7.1. Clean the inlet-filter

Disconnect the vacuum connection line of your vacuum system from the pump inlet-port. Take out the inlet filter from the inlet flange and clean the inlet filter with blast air or an appropriate cleaning agent.

### 7.7.2. Anti suck-back valve cleaning

Make sure that the anti-suck back valve is cleaned at the same time when you are cleaning the inlet filter, clean using appropriate cleaning agent for proper operation of pump. If the pump is exposed to large amounts of dust or dirt, we strongly recommend installing a dust filter upstream. To access anti-suck back valve, remove the inlet flange with O-ring by opening screws on it.



### 7.7.3. Clean the gas-ballast valve

1. By removing the side screw near gas ballast, you can remove the gas ballast knob by unscrewing it and then remove the internal parts and filter.
2. Clean the parts surfaces and seals ensuring no debris is falls into the gas-ballast hole of the pump.
3. Clean the filter with blast of compressed air.
4. Reassemble in the reverse sequence.

### 7.7.4. Clean the oil-level sight-glass

1. Drain the oil before disassembling the oil-level sight glass as describe in section [Replacement of Oil](#) on page 55.
2. Unscrew the oil-level sight glass along with the washer from the oil-tank.
3. Clean the oil-level sight glass with a suitable cleaning solution.
4. Wipe the washer with a clean, dry, lint-free cloth.
5. Refit the oil-level sight glass along with the washer and secure it into the oil tank.
6. Make sure that the oil drain plug along with the washer is in plugged in the oil-tank before refilling the oil.
7. Refill the pump with oil.
8. Check that the sight-glass does not leak.

### 7.7.5. Cleaning

#### **Cleaning the fan covers of motor GVS 16 R and GVS 40 R**

The fan on motor is coved with fan covers, blockage of air vent grill in fan cover may lead to overheating the pump and motor. Remove the fan covers and clean with blast air. Make sure that the fan covers are reassembled before starting the pump again.

#### **Cleaning the fan covers of motor and pump GVS 65 R and GVS 100 R**

The pumps have two types of fans on either side of pump; one blower fan to cool the pump and the other motor fan to cool the motor, both fans have covers and soiling of the fan covers may lead to overheating of pump and motor. Remove the fan covers and clean with blast air. Make sure that the fan covers are reassembled before starting the pump again.

#### **Cleaning the radiator, fan covers of motor and pump GVS 200 R and GVS 300 R**

The pumps have radiator and fan to cool the pump and at opposite side a fan in motor, both fans has covers and soiling of the fan covers and radiator may lead to overheating of pump and motor. Remove the fan covers, radiator and fans and clean with blast air. Make sure that the fan covers are reassembled before starting the pump again.

### 7.7.6. Clean the oil return line of exhaust mist filter

#### GVS 16 R

The oil return line can be accessed by removing exhaust flange and separating the tank from pump cartridge; you can check the oil return line even while replacing the exhaust mist filter by checking cleanliness of connecting hole. To clean the connecting hole of oil recirculation line, use a wire and blast of air. Clean the surface on exhaust cover and oil tank. Reassemble in reverse sequence.

#### Clean the oil float valves GVS 40 R, GVS 65 R, GVS 100 R, GVS 200 R and GVS 300 R

The oil float valves can be accessed by removing exhaust flange; you can check the oil float valve even while replacing the exhaust mist filters by checking the clean lines and the proper operating of the float valve. To take out oil float valve unscrew nut on the top of the oil float valve using 10 mm spanner and pull out the oil float valve, clean the nozzle and check the float valve is oscillates free around its axis and there is no gap between nozzle face and rubber poppet face when the valve is in closed condition. Clean the oil float chamber and reassemble the oil float valve in reverse sequence.

### 7.7.7. Clean and overhaul the pump

Clean and overhauling the pump should be done by properly trained personnel using appropriate tools.

Follow local and national safety requirements.

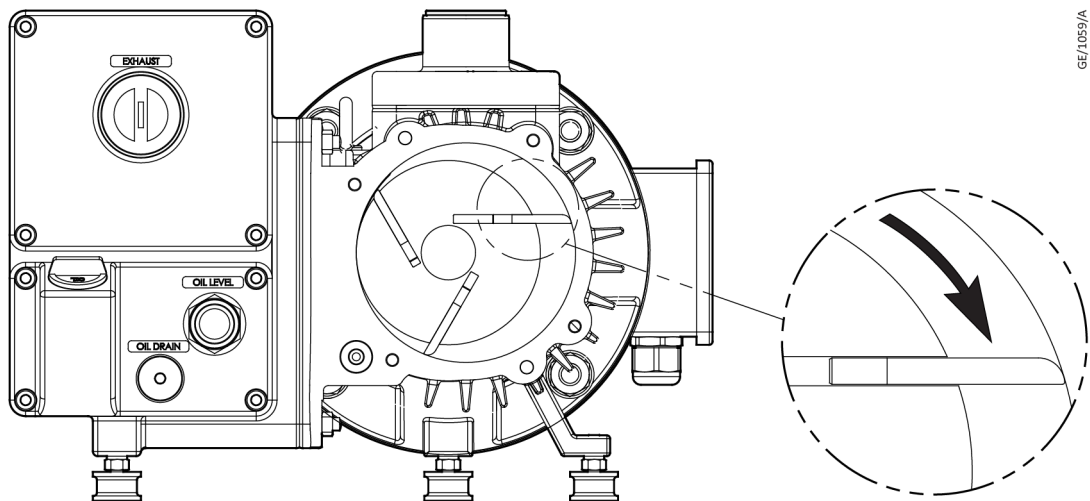
### 7.7.8. Replacing vanes



#### CAUTION: LUBRICATION

Lubricate vanes while replacement, using pump supplier recommended oil.

Fit the new vanes to the pump rotor with vane radius facing bore of stator.



GE/1059/A

**7.7.9. Test the motor condition**

Test the earth (ground) continuity and the insulation resistance of the pump-motor, in accordance with local regulations for periodic testing of electrical equipment.

If the motor fails these tests, you must replace the motor.

## 8. Storage

---



### CAUTION: DAMAGE TO EQUIPMENT

Observe the storage temperature limits. Storage below -20 °C will permanently damage the pump seals.

---

*Note: If you will store a new pump in conditions of high humidity, remove the pump from its cardboard packaging box; dispose of the box.*

Use the following procedure to store the pump:

1. Shut-down the pump as described in [Stop the pump](#) on page 52.
2. Disconnect the pump from the electrical supply.
3. Purge your vacuum system and the pump with dry nitrogen and disconnect the pump from your vacuum system.
4. Replace the oil as described in [Replacement of Oil](#) on page 55
5. Place and secure protective covers over the inlet and outlet-ports.
6. Store the pump in cool, dry conditions until required for use. When required, prepare and install the pump as described in [Installation](#) on page 39. If the pump has been stored for more than a year, before you install the pump you must clean and overhaul it as described in the instructions supplied with the clean and overhaul kit.

## 9. Disposal

Used filters of the pump or any other used material (for example, lubricants, cleaning rags, machine parts, etc.) must be disposed safely in accordance with all local and national safety and environmental requirements.

Take particular care with components and waste oil which have been contaminated with dangerous process substances.

## 10. Fault finding

A list of fault conditions and their possible causes is provided in the following sections to assist you in fault-finding. If you are unable to rectify a fault when you use this guide, call your nearest pump supplier Service Centre for help (For contact details refer last sheet of manual).

**Table 14 Fault finding**

Conditions
<i>Pump does not start</i> on page 62
<i>Pump does not reach ultimate pressure</i> on page 63
<i>Pumping speed is too low.</i> on page 63
<i>Oil in intake line or in vacuum chamber after switching off pump under vacuum, pressure in system rises too fast.</i> on page 64
<i>Pump gets too hot</i> on page 64
<i>Pump's oil consumption too high, oil mist at exhaust.</i> on page 65
<i>Oil is turbid</i> on page 65
<i>Pump is excessively noisy</i> on page 65
<i>Oil leakage</i> on page 66

### Fault Pump does not start

#### Cause Defective motor or wired wrong.

Remedy Check the voltage, the frequency, motor type, power consumption, rotation, wiring connections, phase consistency.

#### Cause Wrong motor connections.

Remedy Remedy text goes here

#### Cause Motor protection switch incorrectly set.

Remedy Set motor protections switch properly.

#### Cause Pump seized.

Remedy Disassemble and repair the pump.

#### Cause Oil temperature is below 12 °C.

Remedy Heat the pump and pump oil or use different oil.

#### Cause Oil is too viscous.

Remedy Use appropriate oil grade.

#### Cause Exhaust filter / exhaust line is clogged.

Remedy Replace the filter / clean the exhaust line.

<b>Fault</b>	<b>Pump does not reach ultimate pressure</b>
<b>Cause</b>	<b>Leakage in suction piping.</b>
Remedy	Repair piping; check valves for leakage.
<b>Cause</b>	<b>High back pressure.</b>
Remedy	Exhaust mist filter is clogged or check the exhaust line for obstructions or high friction losses.
<b>Cause</b>	<b>Bad sealing.</b>
Remedy	Replace the defective oil seals and O-Rings.
<b>Cause</b>	<b>Pump undersized.</b>
Remedy	Check the process data; replace the pump, if necessary.
<b>Cause</b>	<b>Pump worn-out.</b>
Remedy	Disassemble and repair the pump.
<b>Cause</b>	<b>Measuring technique or gauge is unsuitable or Instrumentation out of calibration.</b>
Remedy	Use correct measuring technique and gauge. Check the Working characteristics, replace if required.
<b>Cause</b>	<b>Inadequate lubrication due to unsuitable or contaminated oil, clogged oil lines.</b>
Remedy	Change the oil. Clean the oil lines and oil case.
<b>Cause</b>	<b>Pump has not warmed up.</b>
Remedy	Let the pump to warm-up to working temperature.
<b>Cause</b>	<b>Anti-suck back valve is malfunctioning.</b>
Remedy	Repair or replace the valve.
<b>Cause</b>	<b>Vacuum lines are dirty.</b>
Remedy	Clean vacuum lines.
<b>Cause</b>	<b>Oil return valve or float valve does not close</b>
Remedy	Replace the valve.
<b>Fault</b>	<b>Pumping speed is too low.</b>
<b>Cause</b>	<b>Dirt trap in the intake port is clogged.</b>
Remedy	Clean the dirt trap; Precaution: install a dust filter in intake line.

**Cause Exhaust mist filter is clogged.**

Remedy Install new filter elements.

**Cause Inlet-filter is blocked clogged.**

Remedy Clean the Inlet-filter.

**Cause Anti-suck back valve is hard to open.**

Remedy Check spring free length.

**Cause Connecting lines are too narrow or too long.**

Remedy Use adequately wide and short connecting lines.

**Fault Oil in intake line or in vacuum chamber after switching off pump under vacuum, pressure in system rises too fast.**

**Cause Oil comes from the vacuum system.**

Remedy Check the vacuum system.

**Cause Anti-suck back valve is obstructed.**

Remedy Clean or repair the valve

**Cause Sealing surfaces of anti-suck back valve are damaged or dirty.**

Remedy Clean or repair the intake port and valve.

**Cause System has a leak.**

Remedy System has a leak.

**Cause Anti-suck back valve is obstructed.**

Remedy Clean or repair the valve.

**Cause The gas ballast valve is open.**

Remedy Close the gas ballast valve.

**Cause Sealing surfaces of anti-suck back valve are damaged or dirty.**

Remedy Clean or repair the intake port and valve.

**Fault Pump gets too hot**

**Cause Cooling air supply is obstructed.**

Remedy Maintain minimum distance for air entry

**Cause Ambient temperature is too high.**

Remedy Set pump up correctly.



<b>Cause</b>	<b>Process gas is too hot.</b>
Remedy	Check the process.
<b>Cause</b>	<b>Oil level is too low.</b>
Remedy	Add oil to reach the correct oil level.
<b>Cause</b>	<b>Oil is contaminated.</b>
Remedy	Change the oil or open the gas ballast valve.
<b>Cause</b>	<b>Oil is unsuitable.</b>
Remedy	Change the oil.
<b>Cause</b>	<b>Oil cycle is obstructed.</b>
Remedy	Clean the oil lines.
<b>Cause</b>	<b>Exhaust filter / exhaust line is obstructed.</b>
Remedy	Replace the exhaust filter, clean the exhaust line.
<b>Cause</b>	<b>Cooler is dirty.</b>
Remedy	Clean the cooler (Fan and cover of motor).

<b>Fault</b>	<b>Pump's oil consumption too high, oil mist at exhaust.</b>
<b>Cause</b>	<b>Exhaust filters are clogged or damaged.</b>
Remedy	Install new filter elements.
<b>Cause</b>	<b>Oil return line of exhaust mist filter is clogged.</b>
Remedy	Clean the oil return line.
<b>Cause</b>	<b>Oil level is too high.</b>
Remedy	Drain the excess oil.

<b>Fault</b>	<b>Oil is turbid</b>
<b>Cause</b>	<b>Condensation</b>
Remedy	Change the oil and clean the pump. Precaution: Open the gas ballast valve when pumping condensates.

<b>Fault</b>	<b>Pump is excessively noisy</b>
<b>Cause</b>	<b>Coupling misalignment.</b>
Remedy	Re-align the pump and motor coupling assembly.

**Cause**      **Coupling element (spider) is worn.**

Remedy      Install new coupling element.

**Cause**      **Oil level is very low (oil is no longer visible).**

Remedy      Add oil

**Cause**      **Large vacuum leak in system.**

Remedy      Repair vacuum leak.

**Cause**      **Fan-cover is damaged.**

Remedy      Repair or replace the fan covers.

**Cause**      **Motor or pump bearings are worn.**

Remedy      Install new bearings.

**Cause**      **Oil circulation lines are clogged.**

Remedy      Clean the oil circulation line.

#### **Fault**      **Oil leakage**

**Cause**      **Glass or washer of oil level sight indicator has broken.**

Remedy      Replace the oil level sight-glass.

**Cause**      **O-Rings, washers or oil seals have worn-out or damaged or not cleaned.**

Remedy      Replace or clean O-Rings or washers or oil seals.

**Cause**      **Improper cross-section or size of ORings, washers or oil seals is used.**

Remedy      Use pump supplier recommended spares.

## 11. Service

### 11.1. Return the equipment or components for service

Before you send your equipment to us for service or for any other reason, you must complete a Declaration of Contamination Form. The form tells us if any substances found in the equipment are hazardous, which is important for the safety of our employees and all other people involved in the service of your equipment. The hazard information also lets us select the correct procedures to service your equipment.

If you are returning equipment note the following:

- If the equipment is configured to suit the application, make a record of the configuration before returning it. All replacement equipment will be supplied with default factory settings.
- Do not return equipment with accessories fitted. Remove all accessories and retain them for future use.
- The instruction in the returns procedure to drain all fluids does not apply to the lubricant in pump oil reservoirs.

Download the latest documents from [atlascope.com/en-uk/vacuum-solutions/vacuum-pump-service/health-and-safety-forms](https://atlascope.com/en-uk/vacuum-solutions/vacuum-pump-service/health-and-safety-forms), follow the procedure in HS1, fill in the electronic HS2 form, print it, sign it, and return the signed copy to us.



#### NOTICE:

If we do not receive a completed form, your equipment cannot be serviced.

### 11.2. Service kits

For overhauling and for preventive maintenance, a wide range of service kits is available. Service kits comprise all parts required for servicing the component and offer the benefits of genuine parts while keeping the maintenance budget low.

Also, a full range of extensively tested lubricants, suitable for your specific needs is available to keep the vacuum pump in excellent condition.

Refer to [Table: Spares kits GVS R](#) for part numbers

**Table 15 Spares kits GVS R**

Kit name	Part number
<b>GVS 16 R</b>	
Sealing kit	2031000425
Vane kit	2031000426
Clean and overhaul kit	2031000427
Cartridge kit	2031000428

<b>Kit name</b>	<b>Part number</b>
Filter kit	2031000429
Oil return valve kit	2031000430
Special tool kit	2031000431
Standard tool kit	2031000432
<b>GVS 40 R</b>	
Sealing kit	2031001425
Vane kit	2031002426
Clean and overhaul kit	2031001427
Cartridge kit	2031002428
Filter kit	2031002429
Float valve kit	2031002087
Special tool kit	2031001431
Standard tool kit	2031001432
<b>GVS 65 R</b>	
Sealing kit	2031002425
Vane kit	2031002426
Clean and overhaul kit	2031002427
Cartridge kit	2031002428
Filter kit	2031002429
Float valve kit	2031002087
Cooling kit	2031002431
Special tool kit	2031002432
Standard tool kit	2031002433
<b>GVS 100 R</b>	
Sealing kit	2031003425
Vane kit	2031003426
Clean and overhaul kit	2031003427
Cartridge kit	2031003428
Filter kit	2031003429
Float valve kit	2031002087
Cooling kit	2031002431
Special tool kit	2031003432
Standard tool kit	2031003433
<b>GVS 200 R</b>	
Sealing kit (O-rings and Oil seals)	2031004425
Vane kit	2031004426
Clean and overhaul kit	2031004427
Cartridge kit	2031004428
Filter kit	2031004429

<b>Kit name</b>	<b>Part number</b>
Float valve kit	2031002087
Cooling kit	2031004431
Special tool kit	2031005432
Standard tool kit	2031005433
<b>GVS 300 R</b>	
Sealing kit (O-rings and Oil seals)	2031005425
Vane kit	2031005426
Clean and overhaul kit	2031005427
Cartridge kit	2031005428
Filter kit	2031005429
Float valve kit	2031002087
Cooling kit	2031005431
Special tool kit	2031005432
Standard tool kit	2031005433

**Table 16 Oil kits**

<b>Description</b>	<b>Part number</b>	<b>Quantity</b>
Mineral Oil 1 Litre	2031000478	1
Mineral Oil 5 Litre	2031000479	1
Mineral Oil 10 Litre	2031000480	1
Mineral Oil 20 Litre	2031000481	1

This page has been intentionally left blank.

This page has been intentionally left blank.

