



AIRNET

06
2024

Stainless Steel

Installation and Assembly Guide

Table of content

AIRnet Installation Instructions	3
Notice A: Certified Installer	
Notice B: Complete Comprehension	
Operating Conditions, Installations in explosive environments, Purity Remark & Safety Instructions	4
Product Information	6
LMRA (Last Minute Risk Assessment)	7
Commissioning Report	9
Cleaning Products	11
Expansion Loops and Compensators	12
Pipe Support	14
Tools	15
Overview	15
Inspection and Maintenance	16
Installation	17
Pipe Preparation	17
Diameters 15 -35 mm / 1/2" - 1 1/4"	19
Diameters 42 - 54 mm / 1 1/2" - 2"	20
Diameters 76 - 108 mm / 2 3/4" - 4"	21
Minimum Distances and Space Requirements for Pressing	22



Two concentric, light blue circles are centered behind the main title and the first notice.

AIRnet Installation Instructions

Notice A: Certified Installer

At AIRnet, we take pride in the quality and safety of our products. That's why we require that all installations are carried out by a certified installer, who is highly trained and equipped to handle all aspects of the installation process.

Notice B: Complete Comprehension

This comprehensive manual must be thoroughly read in its entirety in order to have a complete understanding of the AIRnet assembly process.

Operating Conditions

Operating Conditions

AIRnet stainless steel pipes and fittings are designed to convey compressed air and vacuum. The system can also be used for nitrogen, helium, argon, neon, xenon and krypton.

AIRnet system can only be used to convey compressed air, Vacuum & inert gases and the allowed medium can be in direct contact with the final product or process. However, AIRnet system cannot be used for conveying the finished products, for example, chemicals, food products, cement etc.

AIRnet stainless steel systems must only be used within the pressure and temperature specifications referred to in the AIRnet Stainless Product Information Sheet.



AIRnet stainless steel systems must be appropriately protected against violent impacts and wind gusts.

Ensure accessibility of the AIRnet system for possible future system expansion or maintenance.



AIRnet stainless steel pipes and fittings should not be used as support for electrical equipment or earth conductors.



AIRnet stainless steel pipes should never be directly connected to a source of vibrations (use hoses instead).

AIRnet stainless steel systems support pressure dewpoints up to -70°C and are expected to be operated in C3 and below corrosivity categories according to EN ISO 9223.

Pressure relief valves must be installed where needed to ensure that the system working pressure cannot exceed the maximum working pressure of AIRnet Stainless Steel.



AIRnet pipes and fittings are not suitable for direct contact with soil. A watertight PVC pipe suited for underground or outside installations can be used to install around the AIRnet pipe.

AIRnet Installations in Explosive Environments

Cutting, deburring and assembly of AIRnet stainless steel pipes can create sparks. Necessary precautions in explosive atmospheres must be taken.



AIRnet stainless steel installations in explosive environments must always be earthed. Bonding and earthing must be checked at frequent intervals to secure that the system cannot be electrically charged.

Purity Remarks

To guarantee the purity of the compressed air at the point of use:

- a system purge of at least 24h is highly recommended.
- a properly sized certified point-of-use filter is advised, depending on the application requirements.

AIRnet stainless steel cannot be allowed to convey any end products (food, beverage, pharmaceuticals, etc.)

Safety Instructions

Safety Instructions



AIRnet is not meant to bear weight beside its own weight. Heavier accessories incorporated into the AIRnet system (like filters or valves) need proper supporting.



Do not use any other brand fittings or pipes in combination with AIRnet stainless steel products.



Installation, adjustments and repair work of an AIRnet system must be performed by authorized trained personnel.

Installers must use the necessary protection means (PPMs). When working at heights, use a harness for personal protection, and ensure that tools are securely fastened to prevent them from falling.



Installers must comply to all local safety requirements related to the application(s) in scope. Special care must always be taken to prevent suffocation risks when working with gases other than air.

Please consider the potential galvanic corrosion when combining parts with different material.

Before any installation, adjustment, repair work or other non-routine checks, relieve the AIRnet system of pressure and effectively isolate the system from all sources of pressure.



Only genuine AIRnet parts and tools should be used when installing, adjusting or repairing an AIRnet stainless steel system.



All plugs and caps must be removed before installing the AIRnet pipes.

Check the surface of the AIRnet pipes before installing. There should be no relevant scratches, abrasions, dents etc.



Use only solvents or chemicals which do not damage the materials of AIRnet.



Please conduct an LMRA (last minute risk assessment) before commencing an AIRnet installation.

Before using the AIRnet stainless steel system, installers must ensure that all necessary test controls and applicable rules for the specific installation are complied with.

At initial startup of the AIRnet system, apply a test pressure of 1.5 bar to identify leakage or imperfect joints. After performing an inspection, increase the pressure gradually and constantly (max 1 bar every 5 minutes) and perform a second inspection for leakages or imperfect joints at the final pressure.

Never use damaged AIRnet fittings or tools.

AIRnet
stainless steel
**Product
Information**

AIRnet stainless steel is a piping system designed to deliver a fast, easy, reliable and clean distribution network for compressed air, nitrogen, vacuum specifically for industries that demand the highest quality of air.

Product Range	Pipes SS304L: D15 (1/2"), D22 (3/4"), D28 (1"), D35 (1 1/4"), D42 (1 1/2"), D54 (2"), D76 (2 3/4"), D89 (3 1/2"), D108 (4") Pipes SS316L: D15 (1/2"), D22 (3/4"), D28 (1"), D42 (1 1/2")	
Applications	Compressed Air, Vacuum, Nitrogen, Helium, Argon, Neon, Xenon and Krypton.	
Material	Stainless Steel AISI 316L 1.4404 Stainless Steel AISI 304L 1.4301	EN10088 ASTM A666
Safety factor	4, Burst pressure > 64 Bar (> 928 PSI)	
Working pressure	16 Bar (232 PSI)	
Working temperature	-20°C to 120°C (- 4°F to 248° F)	
Vacuum level	20 mbar (0.29 PSI) abs	
Dewpoint	Lowest allowable pressure dewpoint is -70°C (-94°F)	
Treatment	304L - Unannealing 316L - Annealing	
Fittings	D15 (1/2"), D22 (3/4"), D28 (1"), D35 (1 1/4"), D42 (1 1/2"), D54 (2"), D76 (2 3/4"), D89 (3 1/2"), D108 (4")	
Connection	Press fit system	
Materials	Stainless steel AISI 316L 1.4404	EN10088 ASTM A666
Seal fittings	FKM (fluoroelastomer)	



LMRA (Last Minute Risk Assessment)

This checklist is a risk assessment to be performed on-site at the customer and must be preceded by a detailed risk assessment.

General

STEP 1: EVALUATION BEFORE THE START OF WORK

	YES	NO	N/A
Do I know what to do and how?			
Am I trained to do this kind of work?			
Is my work equipment suitable and in good condition / inspected?			
Do I have the necessary PPE, and do they offer appropriate protection?			
Do I have a work permit that allows me to start?			
Is my working environment free of slipping, tripping and/or falling hazards?			
Is my work environment sufficiently enlightened?			
Have I identified all energy sources and followed the Lock Out – Tag Out procedure?			
Do I know the regulations for using and handling dangerous goods I am going to use?			
Is the atmosphere in and around my work environment safe? (confined space, explosion)			
Is the danger of falling objects excluded?			
Am I sufficiently protected against falls from height?			
Are the weather conditions good?			
Can I lift loads manually in an ergonomic way?			
Is my work environment defined?			
Is there regular supervision when I work in isolation?			
Am I aware of the risks of other activities in my work environment?			
Do I know the locations of first aid equipment (e.g. emergency shower, eyewash bottle)			
Do I know the locations of firefighting equipment (e.g.; extinguisher, reel)			
Do I know the alarm procedure and numbers in the event of a fire or accident?			
Do I know my escape route and evacuation site?			
Have I taken all measures to prevent environmental pollution?			

LMRA (Last Minute Risk Assessment)



	YES	NO	N/A
Did I read and understand the installation manual for AIRnet - www.airnet-system.com			
Is scaffolding and/or lifting equipment inspected and in good condition?			
Will the AIRnet system be installed within the limits of the product in terms of environment, pressure and temperature?			
Will the AIRnet system be used for the gasses mentioned in the technical datasheet OR has a written confirmation from the manufacturer been obtained that claims AIRnet can be used for this type of gas?			
Will the AIRnet system be properly earthed (electrically?)			
Did I check for any damage to the AIRnet material due to transport?			
Did I check if the tools used are in good condition and have been maintained as per requirement?			
Did I check if the right tools are available for carrying out the AIRnet installation?			

STEP 2: MEASURES TO ELIMINATE OR REDUCE EXISTING RISKS TO AN ACCEPTABLE LEVEL

STEP 3: PRESENT WHEN FORMATTING THIS LMRA

Name	Date	Signature

Commissioning Report

All AIRnet commissioning has to be registered in the F3 app!

Go to <https://airnetinstructions.com/> to register your installation and get up-to-date information about AIRnet.

Commissioning data to be collected and submitted in the F3 app as shown below:

Certified installer:	Responsible AIRnet champion:
Customer:	Commissioning date (dd/mm/yyyy):
Customer address:	
<input type="checkbox"/> Expansion of existing installation	<input type="checkbox"/> New installation

Before installation

SAFETY

- All safety instructions at customer site have been acknowledged and applied.
- The AIRnet installation manual (latest version is available on the website: <https://www.airnet-system.com/en>) has been read and understood. The installation is carried out in accordance with the instructions in this manual.

MEDIUM

- Compressed air
- Vacuum
- Nitrogen
- Other: _____

	T _{MAX} _____ °C / °F
	T _{AVG} _____ °C / °F
	T _{MIN} _____ °C / °F
	Working pressure _____ bar(g) / psi

AMBIENT CONDITIONS

The installation is installed:

- Indoor
- Outdoor
- The piping is protected against violent impacts and wind gusts

NETWORK LAYOUT

- To ensure proper draining of condensate, pipes should be sloped at 1-2% and a drain point should be foreseen at every lowest point of the line.
- Ensure that pressure vessels are bolted to the floor, and that vibrations may not be transmitted to the AIRnet piping.
- Expansion loops
Number of expansion loops or compensators: _____
Longest straight line: _____ m/ft

Installation

- Check if enough supporting is used based on the table on the right. The table shows the maximum allowed distance L between two pipe clips.

External pipe diameter (mm / inch)	Maximum distance (m / ft)
15 / ½"	1,5 / 5
22 / ¾"	2 / 6,5
28 / 1"	2,5 / 8
35 / 1 ¼"	2,5 / 8
42 / 1 ½"	3 / 10
54 / 2"	3,5 / 11,5
76 / 2 ¾"	4 / 13
89 / 3 ½"	4,5 / 14,5
108 / 4"	5 / 16

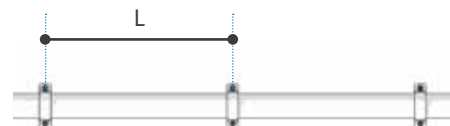

Commissioning Report

All valves and flanges are supported by a pipe clip on both sides

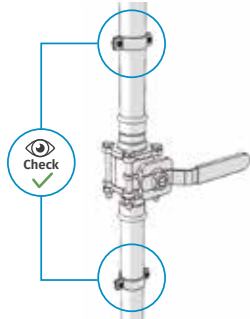

Insertion depth markers have been checked on at least 10% of fittings

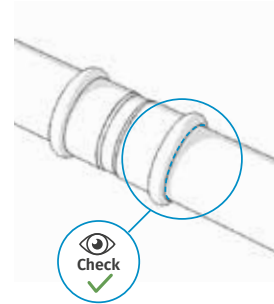

Commissioning

The installation has been tested according to the procedure below

1. Apply pressure of 1,5 bar / 22 psi to the system.
2. Check if the pressure is dropping between the end of the line and the vessel. If pressure remains stable, go to point 4.
3. Use leak finder spray or an ultrasonic leak detector to find the leak. Depressurize the system, rectify the leak and go back to step 1.
4. Increase pressure gradually (max 1 bar / 14 psi every 5 minutes)
5. Close the main valve and monitor the pressure at the end of the line for 30 minutes.
If the pressure is dropping, go to point 3.
6. To be checked: 24h before handover

Leaks / disconnections detected during first pressurization at 1,5 bar / 22 psi

- No
- Yes, _____ leaks found
- Yes, _____ disconnections

Leaks / disconnections detected during final pressurization at working pressure

- No
- Yes, _____ leaks found
- Yes, _____ disconnections

What is the pressure difference between the compressor room and final point of use? _____ bar(g)

Signatures

AIRnet installer	AIRnet champion	Customer representative

Cleaning Products

Product	Usage in the field	Stainless steel 304L	Stainless steel 316L	O-rings in SS fittings
Disinfection/sterilization				
Ethyl Alcohol (ethanol) (60-90%)	Seldom, used on small external surfaces	Good	Good	Good
Isopropyl alcohol (isopropanol)	Seldom, used on small external surfaces	Good	Good	Good
Amphoterics		Good	Good	Unknown
Quaternary ammonium compounds (QAC)	environmental sanitation of noncritical surfaces	Good	Good	Unknown
Gluteraldehyde	high-level disinfectant for medical equipment, not for non-critical surfaces	Good	Good	Unknown
Formaldehyde	Seldom, produces carcinogenic fumes	Good	Good	Good (at concentration of 40% or less)
Whole Room disinfection/sterilization				
QAC fogging		Unknown	Unknown	Unknown
Cleaning (components)				
surfactants (detergents in general)		Good	Good	Good
Ethylene diamine tetracetic acid (EDTA)		Good	Good	Not resistant

Expansion Loops and Compensators

Long straight pipes will expand or contract due to temperature variations. To compensate for this effect, expansion loops or compensators are required. An expansion loop is a U-shaped construction that compensates the variation in length. Compensators are straight fittings specifically designed to allow axial movement. The number of expansion loops / compensators depends on the total length of the straight line and the maximum temperature variation.

The below table gives the maximum possible straight distance between two expansion loops with fixed piping vs. the temperature variation:

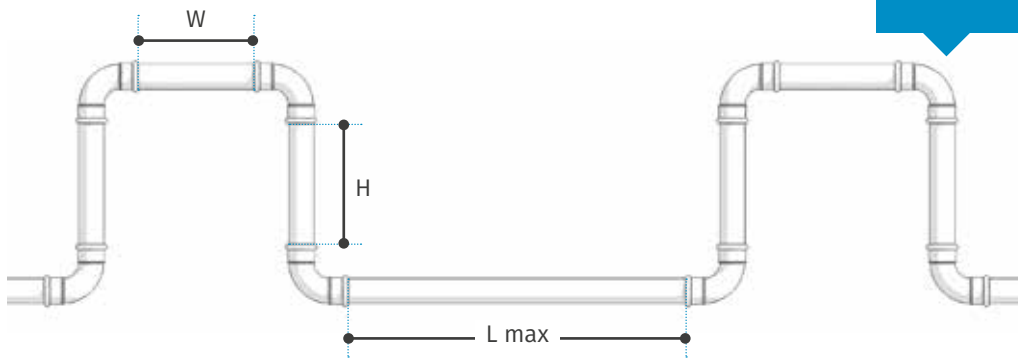

	Ø15 mm / 1/2"	Ø22 mm / 3/4"	Ø28 mm / 1"	Ø35 mm / 1 1/4"	Ø42 mm / 1 1/2"	Ø54 mm / 2"	Ø76 mm / 2 3/4"	Ø89 mm / 3 1/2"	Ø108 mm / 4"
H	1 m / 3,3 ft	1 m / 3,3 ft	1,25 m / 4,1 ft	2 m / 4,9 ft	1,5 m / 4,9 ft	1,75m / 5,7 ft	2 m / 6,6 ft	2 m / 6,6 ft	2,5 m / 8,2 ft
W	0,5 m / 1,6 ft	0,5 m / 1,6 ft	0,63 m / 2,1 ft	1 m / 2,5 ft	0,75 m / 2,5 ft	0,88m / 2,9 ft	1 m / 3,3 ft	1 m / 3,3 ft	1,25 m / 4,1 ft
Δt	Maximum distance between two expansion joints								
5°C / 41°F	698 m / 2291 ft	476 m / 1563 ft	584 m / 1917 ft	673 m / 2209 ft	561 m / 1841 ft	436 m / 1432 ft	551 m / 1808 ft	471 m / 1544 ft	536 m / 1757 ft
10°C / 50°F	349 m / 1145 ft	238 m / 781 ft	292 m / 959 ft	337 m / 1104 ft	281 m / 920 ft	218 m / 716 ft	276 m / 904 ft	235 m / 772 ft	268 m / 878 ft
20°C / 68°F	175 m / 573 ft	119 m / 390 ft	146 m / 479 ft	168 m / 552 ft	140 m / 460 ft	109 m / 358 ft	138 m / 452 ft	118 m / 386 ft	134 m / 439 ft
30°C / 86°F	116 m / 386 ft	79 m / 260 ft	97 m / 320 ft	112 m / 368 ft	94 m / 307 ft	73 m / 239 ft	92 m / 301 ft	78 m / 257 ft	89 m / 293 ft
40°C / 104°F	87 m / 286 ft	60 m / 195 ft	73 m / 240 ft	84 m / 276 ft	70 m / 230 ft	55 m / 179 ft	69 m / 226 ft	59 m / 193 ft	67 m / 220 ft
50°C / 122°F	70 m / 229 ft	48 m / 156 ft	58 m / 192 ft	67 m / 221 ft	56 m / 184 ft	44 m / 143 ft	55 m / 181 ft	47 m / 154 ft	54 m / 176 ft
60°C / 140°F	58 m / 191 ft	40 m / 130 ft	49 m / 160 ft	56 m / 184 ft	47 m / 153 ft	36 m / 119 ft	46 m / 151 ft	39 m / 129 ft	45 m / 146 ft
70°C / 158°F	50 m / 164 ft	34 m / 112 ft	42 m / 137 ft	48 m / 158 ft	40 m / 131 ft	31 m / 102 ft	39 m / 129 ft	34 m / 110 ft	38 m / 125 ft
80°C / 176°F	44 m / 143 ft	30 m / 98 ft	37 m / 120 ft	42 m / 138 ft	35 m / 115 ft	27 m / 89 ft	34 m / 113 ft	29 m / 97 ft	33 m / 110 ft
90°C / 194°F	39 m / 127 ft	26 m / 87 ft	32 m / 107 ft	37 m / 123 ft	31 m / 102 ft	24 m / 80 ft	31 m / 100 ft	26 m / 86 ft	30 m / 98 ft
100°C / 212°F	35 m / 115 ft	24 m / 78 ft	29 m / 96 ft	34 m / 110 ft	28 m / 92 ft	22 m / 72 ft	28 m / 90 ft	24 m / 77 ft	27 m / 88 ft

Expansion Loops and Compensators

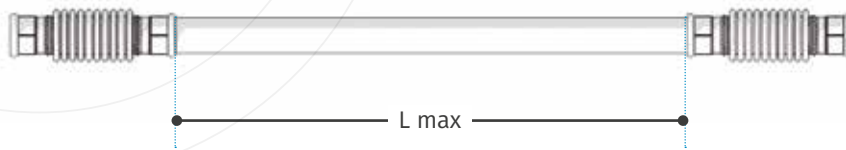

The table below gives the maximum possible straight distance between two compensators vs. the temperature variation:

	Ø15 mm / 1/2"	Ø22 mm / 3/4"	Ø28 mm / 1"	Ø35 mm / 1 1/4"	Ø42 mm / 1 1/2"	Ø54 mm / 2"
Δt	Maximum distance between two compensators (800 cycles max.)					
5°C / 41°F	194 m / 636 ft	242 m / 795 ft	267 m / 875 ft	315 m / 1034 ft	388 m / 1273 ft	436 m / 1432 ft
10°C / 50°F	97 m / 318 ft	121 m / 398 ft	133 m / 437 ft	158 m / 517 ft	194 m / 636 ft	218 m / 716 ft
20°C / 68°F	48 m / 159 ft	61 m / 199 ft	67 m / 219 ft	79 m / 258 ft	97 m / 318 ft	109 m / 358 ft
30°C / 86°F	32 m / 106 ft	40 m / 133 ft	44 m / 146 ft	53 m / 172 ft	65 m / 212 ft	73 m / 239 ft
40°C / 104°F	24 m / 80 ft	30 m / 99 ft	33 m / 109 ft	39 m / 129 ft	48 m / 159 ft	55 m / 179 ft
50°C / 122°F	19 m / 64 ft	24 m / 80 ft	27 m / 87 ft	32 m / 103 ft	39 m / 127 ft	44 m / 143 ft
60°C / 140°F	16 m / 53 ft	20 m / 66 ft	22 m / 73 ft	26 m / 86 ft	32 m / 106 ft	36 m / 119 ft
70°C / 158°F	14 m / 45 ft	17 m / 57 ft	19 m / 62 ft	23 m / 74 ft	28 m / 91 ft	31 m / 102 ft
80°C / 176°F	12 m / 40 ft	15 m / 50 ft	17 m / 55 ft	20 m / 65 ft	24 m / 80 ft	27 m / 89 ft
90°C / 194°F	11 m / 35 ft	13 m / 44 ft	15 m / 49 ft	18 m / 57 ft	22 m / 71 ft	24 m / 80 ft
100°C / 212°F	10 m / 32 ft	12 m / 40 ft	13 m / 44 ft	16 m / 52 ft	19 m / 64 ft	22 m / 72 ft

Example:

Consider an installation with a 100m / 328 ft straight line in 15mm / 1/2" pipe. The minimum temperature of the system is -20°C / -4°F in the winter, and the maximum temperature is 50°C / 122°F due to hot compressed air when the system is in use. The Δt is then 70°C / 126°F.

For this 100m / 328 ft straight line, this means that 2 expansions loop is required. This means that for this straight line, 7 compensators are required.

Pipe Support

The maximum distance L between two pipe clips is given by the table below:

Make sure the piping system is rigidly supported to the structure of the building so that movement due to external forces (e.g. wind) of the piping is prevented.

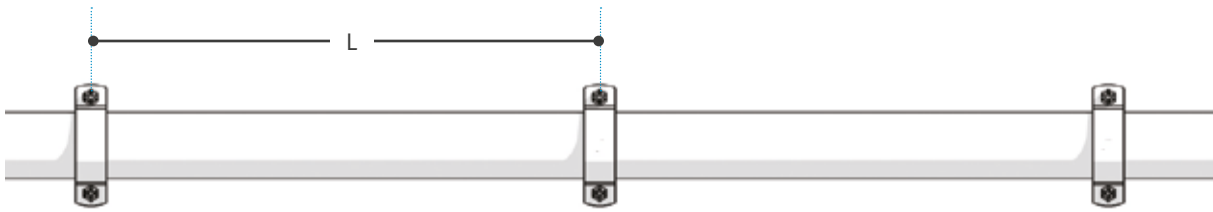

External Pipe Diameter (mm / inch)	Maximum distance (m / ft)
15 / ½"	1,5 / 5
22 / ¾"	2 / 6,5
28 / 1"	2,5 / 8
35 / 1 ¼"	2,5 / 8
42 / 1 ½"	3 / 10
54 / 2"	3,5 / 11,5
76 / 2 ¾"	4 / 13
89 / 3 ½"	4,5 / 14,5
108 / 4"	5 / 16

Valves must be supported by a pipe clip on both sides, with a maximum distance of 0.5m (20") between the valve and the pipe clips.

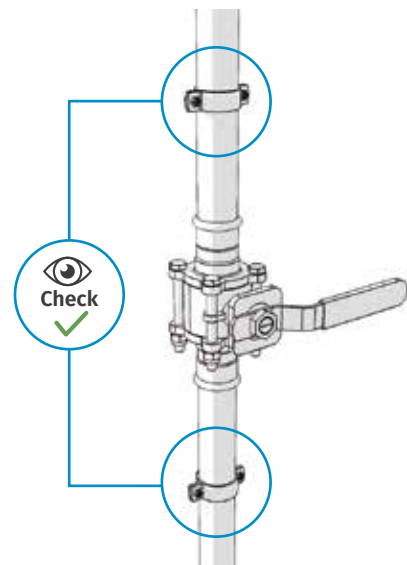

Tools - Overview

D15 - D35

1/2" - 1 1/4"

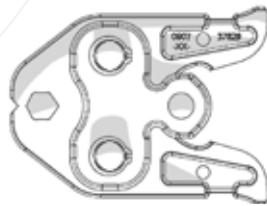

D15 / 1/2" = 2812 1030 00
 D22 / 3/4" = 2812 1030 22
 D28 / 1" = 2812 2030 00
 D35 / 1 1/4" = 2812 3030 00

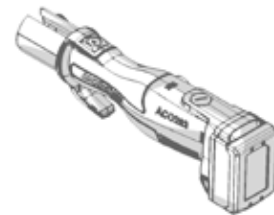

230V: 2812 0030 00
 110V: 2812 0030 01
 Including protective case,
 battery charger, charger cable

D42 - D54

1 1/2" - 2"

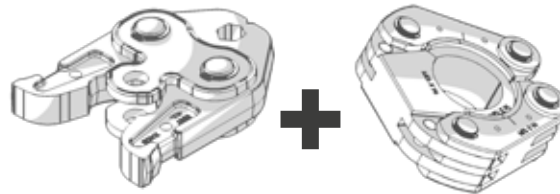

2812 4530 00

D42 / 1 1/2" = 2812 4030 00
 D54 / 2" = 2812 5030 00

Spare parts:
 Charger: 230V: 2812 0430 00
 110V: 2812 0430 01
 Battery: 2812 0230 00
 Cable to work on grid power:
 2812 0428 01 (110V)
 2812 0428 00 (220V)

D76 - D108

2 3/4" - 4"

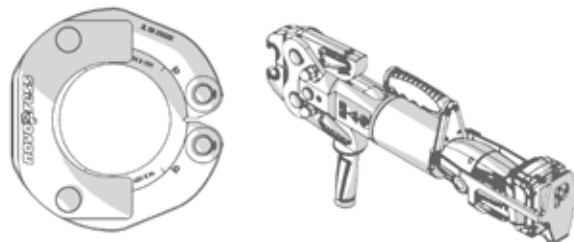

D76 / 2 3/4" = 2812 6030 00
 D89 / 3 1/2" = 2812 7030 00
 D108 / 4" = 2812 8030 00

230V: 2812 0130 00
 110V: 2812 0130 01
 Including protective case,
 battery charger, charger cable,
 cable to work on power grid

Spare parts:
 Charger: 230V: 2812 0430 00
 110V: 2812 0430 01
 Battery: 2812 0230 00
 Cable to work on grid power:
 2812 0428 01 (110V)
 2812 0428 00 (220V)

Note: the AIRnet Stainless Steel System will only attain the designed pressure when installed using the tools in the table above. Using other tools is not recommend, as this may lower the pressure rating.

Tools - Inspection and Maintenance

To guarantee correct installation, the pressing tools must be checked regularly by an official authorized repairer according to the manufacturer specifications. All moving parts and pressing surfaces must be cleaned and lubricated daily. Before starting installation, make sure to inspect the tools thoroughly. Any possible oxidation, paint or dirt will affect the reliability, possibly resulting in sliding issues on the fittings during pressing.

		Klauke D15 - D54									Klauke D76 - D108				
		15	18	22	28	35	42	54	Chain + collar 42	Chain + collar 54	Battery/charger	76	89	108	Battery/charger
Novopress ACO 203 BT	15	YES													
	18		YES												
	22			YES											
	28				YES										
	35					YES									
	42						NO								
	54							NO							
	Chain + collar 42								YES						
	Chain + collar 54									YES					
Battery/charger										NO					
Novopress ACO 403 BT	76										NO				
	89											NO			
	108												NO		
	Battery/charger													NO	

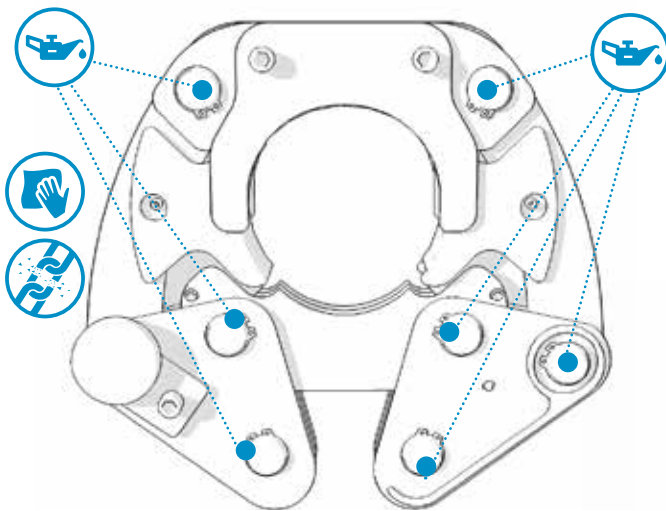

New "Novopress" tool compatibility with old "Klauke" tool:

- D15 - D35 jaws are interchangeable
- D42 - D54 the chain of Klauke is not compatible with collar of Novopress and vice versa
- D42 - D54 the combination of chain and collars is interchangeable with both tools
- D76 - D108 collars are not interchangeable

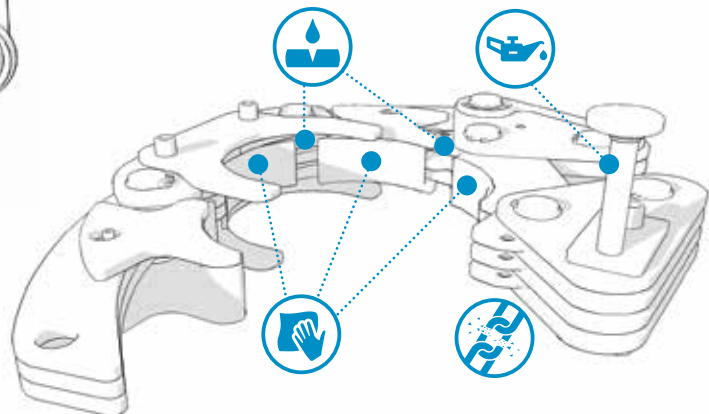

Installation - Pipe Preparation

1 Measure

Pipe Outside Diameter (mm/inch)	A (mm/inch)	D (mm/inch)	L (mm/inch)
15 / 1/2"	20 / 13/16"	20 / 13/16"	60 / 2 3/8"
22 / 3/4"	21 / 1 1/4"	20 / 13/16"	62 / 2 1/2"
28 / 1"	23 / 15/16"	20 / 13/16"	66 / 2 5/8"
35 / 1 1/4"	26 / 1"	20 / 13/16"	72 / 2 13/16"
42 / 1 1/2"	30 / 1 3/8"	40 / 1 9/16"	100 / 5 1/2"
54 / 2"	35 / 1 3/8"	40 / 1 9/16"	110 / 4 5/8"
76 / 2 3/4"	55 / 2 3/8"	60 / 2 3/8"	170 / 6 1/4"
89 / 3 1/2"	60 / 2 3/8"	60 / 2 3/8"	180 / 7 1/8"
108 / 4"	75 / 2 13/16"	60 / 2 3/8"	210 / 8 1/4"

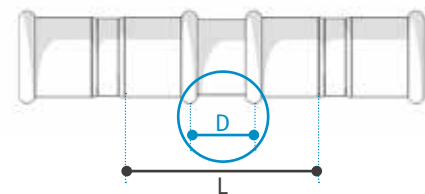
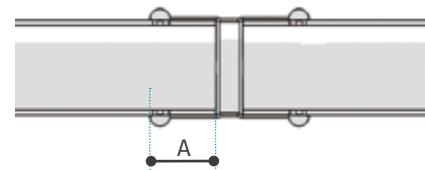

A = Insertion Depth
D = Minimum Distance
L = Minimum Pipe Length Tube

2 Cut

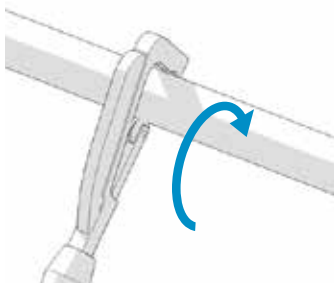

Ø 15-54 mm 2812 0040 00

OR

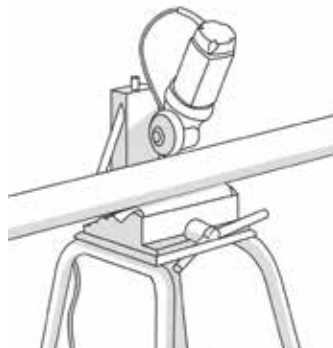

110V (complete kit) 2812 0340 80
220V (complete kit) 2812 0240 80

The 'complete kit' contains:

- 1 x Pipe cutter tool
- 1 x Wheel stand for pipe cutter
- 2 x Tripod for pipe support
- 1 x Cutting wheel

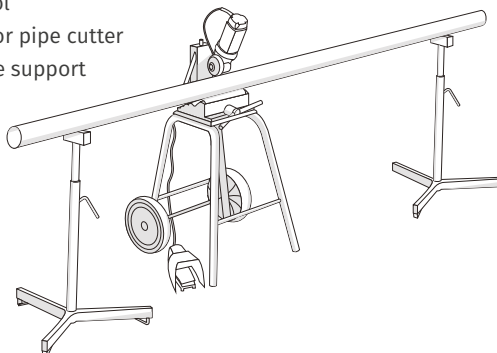

Pipe cutter tool – 110V (1 pc)	2812 0340 81
Pipe cutter tool – 220V (1 pc)	2812 0240 81
Wheel stand (1 pc)	2812 0740 00
Tripod (1 pc)	2812 0840 00
Spare cutting wheel for pipe cutter (1 pc)	2812 0640 00
Spare pipe rollers for pipe cutter (set of 4pcs)	2812 0940 00

Installation - Pipe Preparation

3 Check

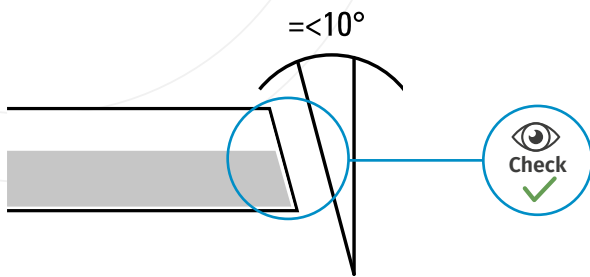

4 Deburr

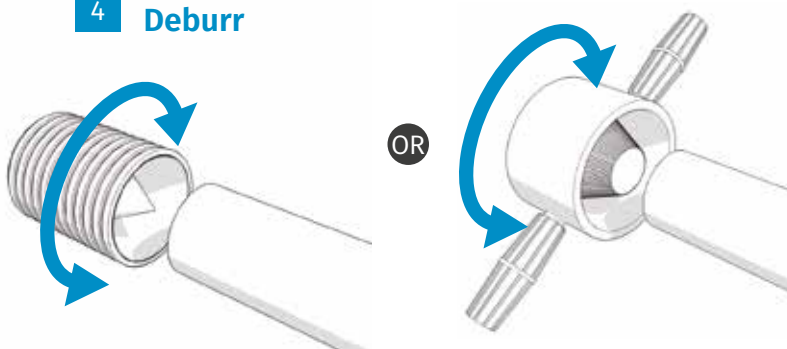

Ø 15-54 mm

2810 0141 00

Ø 76 - 108 mm

2810 0641 00

5 Mark

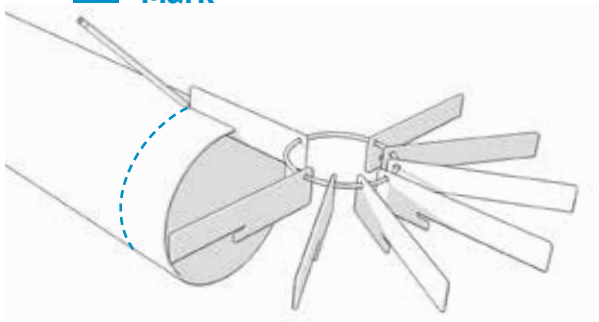

Pipe Marker

2812 0029 80

Installation - Press Fitting

Diameters 15 - 35 mm / 1/2" - 1 1/4"

0 Check O-ring
for damage

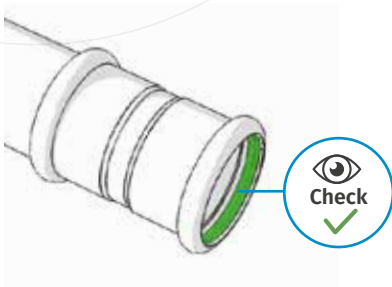

1 Insert

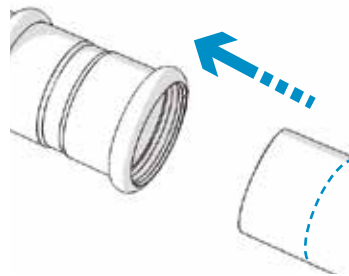

2 Check

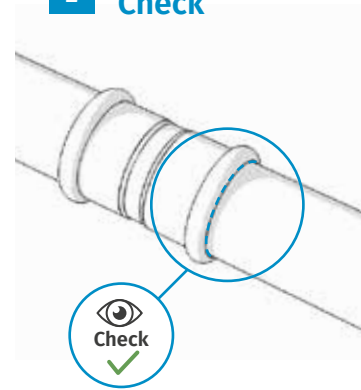

3 Press

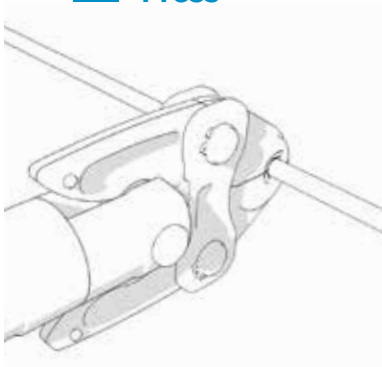

4 Check

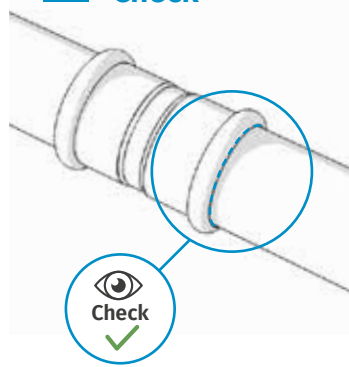

5 Check distance

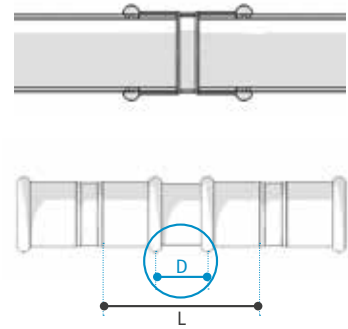

A = Insertion Depth
D = Minimum Distance
L = Minimum Pipe Length Tube

Installation - Press Fitting

Diameters 42 - 54 mm / 1 1/2" - 2"

0 Check O-ring
for damage

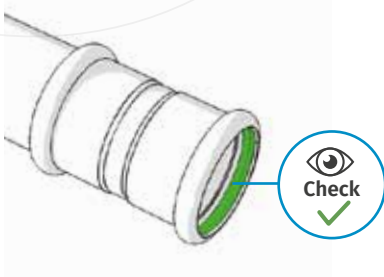

1 Insert

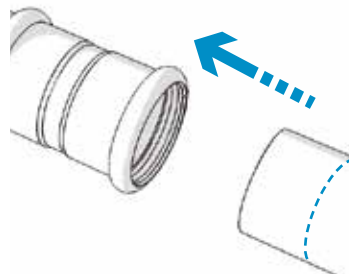

2 Retract pin and
open chain

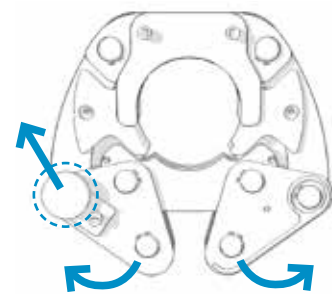

3 Close chain and
insert pin

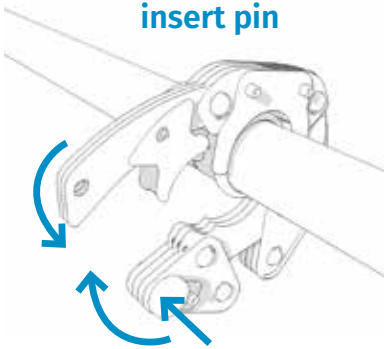

4 Mount adapter

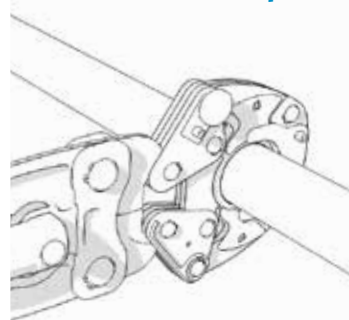

5 Check

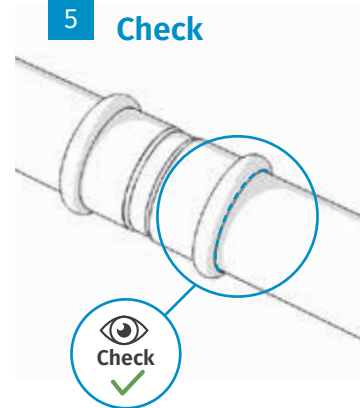

6 Check distance

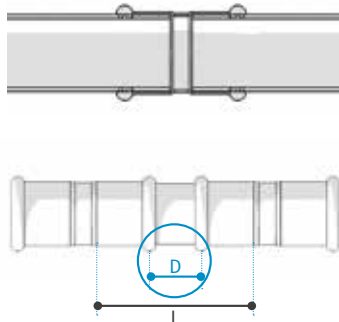

7 Press

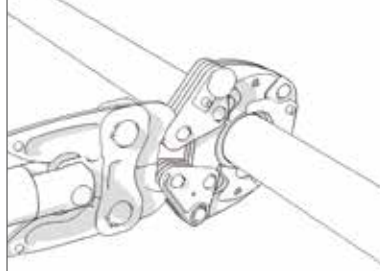

8 Check

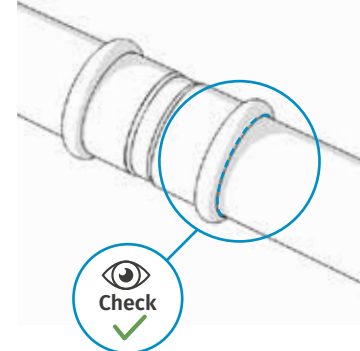

Installation - Press Fitting

Diameters 76 - 108 mm / 2 ¾" - 4"

0 Check O-ring
for damage

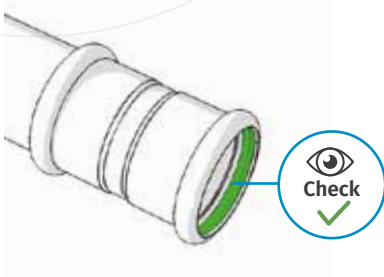

1 Insert

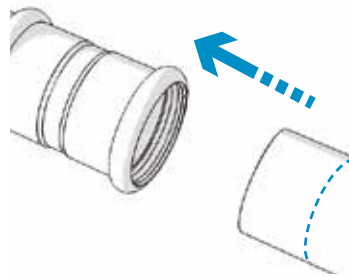

2 Retract pin and
open chain

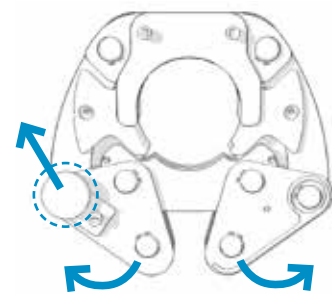

3 Close chain and
insert pin

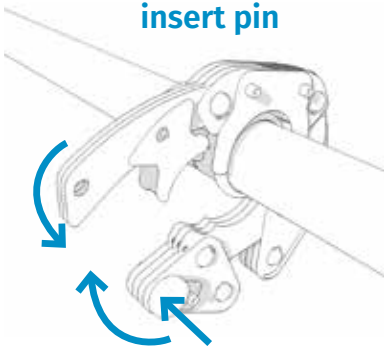

4 Check

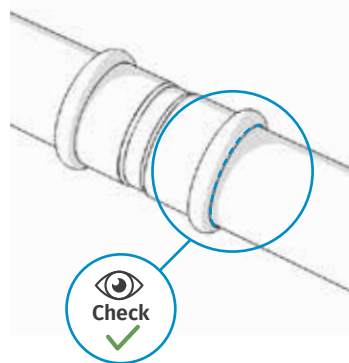

5 Check distance

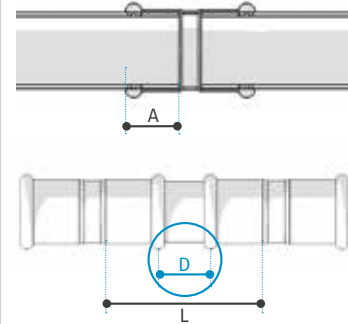

A = Insertion Depth

D = Minimum Distance

L = Minimum Pipe Length Tube

6 Press

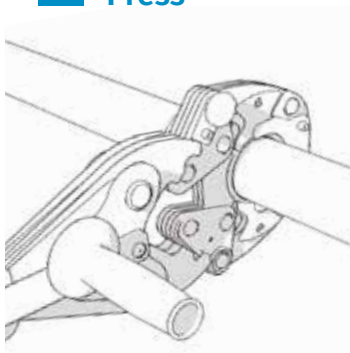

7 Check

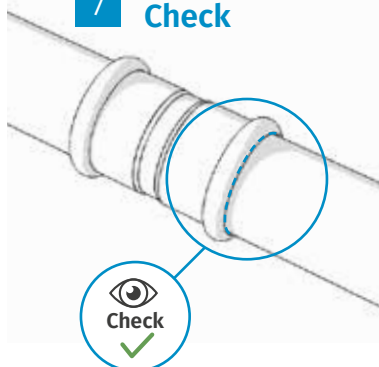

Installation - Press Fitting

To carry out pressing correctly, there must be a minimum distance between the pipe and the building, and from pipe to pipe as shown in the tables below.

Minimum distances and space requirement 15 - 35 mm

Pipe Ø	Figure 1		Figure 2			Figure 3			Figure 4		
	A	D	A	D	D1	A	C	D	D1	D	E
15	56	30	75	30	35	85	155	30	35	40	60
22	75	40	80	40	40	85	165	40	40	40	61
28	82	40	90	40	45	90	180	40	45	40	63
35	85	40	90	40	45	90	180	40	45	40	66

Minimum distances 42 - 108 mm

Pipe Ø	Figure 4		Figure 5		
	D	E	A	B	C
42	50	80	150	150	110
54	50	85	150	150	110
76	60	115	170	210	170
89	60	120	190	260	190
108	60	135	200	320	280

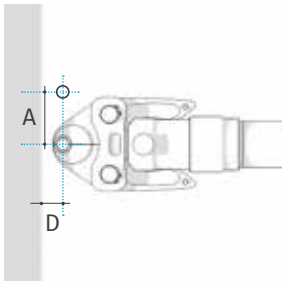

Figure 1 - Minimum distances and space requirements

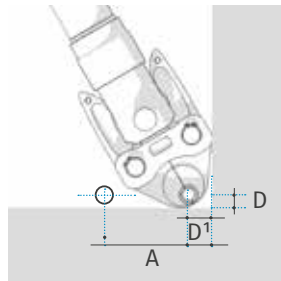

Figure 2 - Minimum distances and space requirements

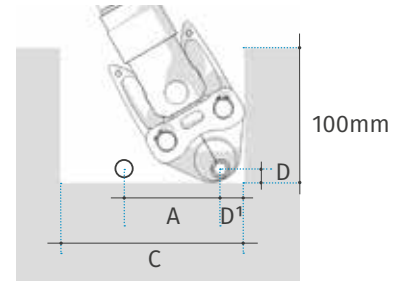

Figure 3 - Minimum distances and space requirements

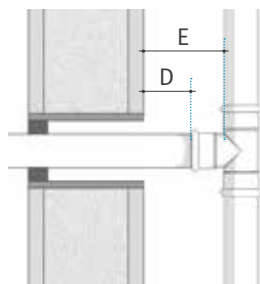

Figure 4 - Minimum distances and space requirements

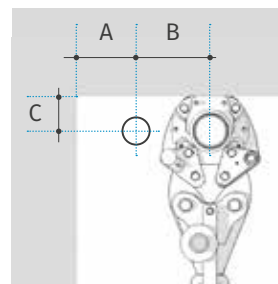

Figure 5 - Minimum distances for chains / collars



Preserving the power of air

www.airnet-system.com